

PremiumCut

The waterjet cutting system with unlimited cutting options

Our solution:

Performance, efficiency and highest possible precision



PremiumCut

The waterjet cutting system with unlimited cutting options

STM PREMIUM cutting systems are high-performance systems with full equipment which leave nothing to be desired. They are ideally suited for cutting tasks with high demands on precision and high speeds, as well as for pipe machining. The systems operate resource-efficiently and are notable for their extremely low consumption of power and air. Maximum upgrade possibilities and adaptability set the systems apart.

All components and screw fasteners of the design are made of wear-resistant stainless steel or aluminium. Characteristic are the flat underside, smooth side panels with concealed linear guides without bellows and high pressure pipe led through the axes. The fully digital drive consists of brushless AC servomotors with multiple-axis CNC control unit. The matching software runs on MS-Windows and requires only a standard PC.

The tried and tested STM PremiumCut systems combined with the innovative STM 3D cutting head complete a universal waterjet cutting system. A selection of three different models is available with cutting angles of up to 12°, 48° or 68°. Moreover the 5-axis kinematics provide a cutting angle error compensation and thus increased precision at the cutting edge. The integrated collision protection provides additional safety.

- ▶ PREMIUM guide X & Y-axis with Bosch Rexroth™ with high-precision ball bearing carriage and stainless steel balls
- ▶ High precision and robust rack and pinion drive with helical toothed rack
- ▶ Triple dirt wiper package
- ▶ Working area accessible from three sides for simplified loading and unloading
- ▶ Working area accessible from three sides for simplified loading and unloading
- ▶ Underwater cutting is possible



Robust and reliable construction

All components and screw fasteners of the are made of wear-resistant stainless steel and aluminium. Characteristic for the extremely low-vibration design are the flat underside and smooth side panels.



Minimal tooling and maintenance costs

STM systems are manufactured without bellows. The standard water-protected linear guide is consequently easy to clean, exhibits a superior protective effect and is capable of many years of use.



Remote maintenance and online shop

The STM service team is delighted to provide support via remote maintenance. Wear and spare parts can be ordered cost-efficiently via the online shop at any time.



Protective of resources and the environment

STM systems are distinguished by their low operating costs. The waterjet cutting systems are designed to use as little compressed air, electricity and water as possible.

Optimally advised

The service team supports you with technical service, training courses and high-quality spare parts. For this purpose an excellently qualified technical support team as well as an extensive customer service network is at your disposal. We continuously advise and comprehensively support you from the initial informatory stage through to the realization of value-creation potential.



Maximum process reliability

Automatic touching and scanning of the workpiece as well as collision protection provide for safe working. STM waterjet cutting systems are able to mark as standard and by means of the laser tracker setting the workpiece up can be done without difficulty.

Low operating costs

STM systems are distinguished by their low operating costs. The waterjet cutting systems are designed to use as little compressed air, electricity and water as possible.



STM SmartCut Software

The easy to understand STM SmartCut cutting software can be adapted to ones own requirements through the addition of modular extensions. Within the graphic user interface all parameters are able to be intuitively set and dxf files directly imported.

Top user comfort

STM waterjet cutting machines are accessible from three sides. Control is made using a classic Windows PC and additional features such as the manual control provide top user comfort.

Our solution:

Perfectly adapted to
your requirements

Cut exactly as you want

The tried and tested PremiumCut systems can be equipped for the most varied cutting tasks. From classic 2D cut through heads with cutting angle error compensation or complex multiple cutting head systems to 3D cutting head with 5 axis kinematics and up to 68° swivel range.

2D Cutting Heads

- ▶ Highest precision and cutting speed
- ▶ Multiple cutting heads in parallel on up to 2 Z-axes
- ▶ Manual rotatable holder for chamfered cuts



STM TAC/12 Taper Angle Control Head

- ▶ Highest precision and cutting speed
- ▶ Working area A-axis up to 12 deg
- ▶ The STM TAC/12 cutting head compensates the taper angle error automatically to +/- 0.05 mm.
- ▶ Integrated height scanning and collision protection
- ▶ Encapsulated mechanics and motors - high wear protection and long service life. No compressed air required for the encapsulation



STM3D68 5-Axis Cutting Head

- ▶ Working area B-axis up to 12 deg, 48 or 68 deg
- ▶ Working area C-axis +/- 720 deg
- ▶ 5-axis cuts, cutting angle error compensation and chamfer cut
- ▶ The cutting head swivels by means of the robot kinematics infinitely through the tool center point. Change cutting angle without X/Y movement
- ▶ Can be equipped with continuous operating height sensor - protects focusing tube and complete cutting head against collisions
- ▶ No raised construction of the cutting bridge necessary - lower weight and drive system requires less power
- ▶ Height sensor can easily be removed - absolute freedom of movement for pure water and abrasive waterjet cutting



Experience flexibility

STM waterjet cutting systems are able to cut almost all solid materials. The spectrum ranges from stone, tiles, glass and metal to foam, rubber, plastic and food.

Depending on your requirements, STM waterjet cutting systems can be equipped with a pure-water package or an abrasive cutting head.

 ABRASIVE  PUREWATER

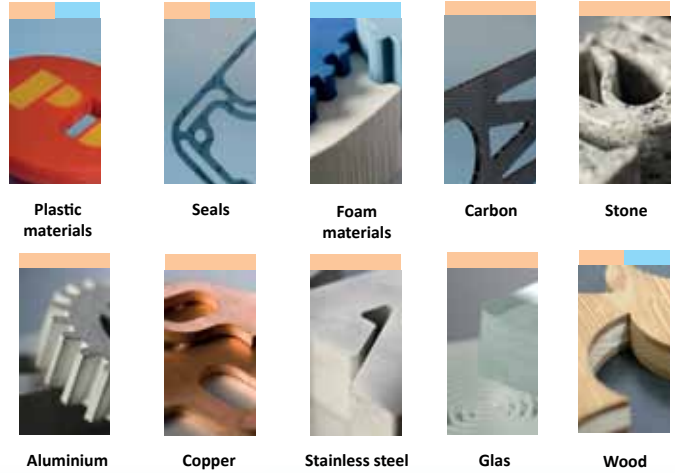

Our solution:
Partnership, precision
and performance

STM is a leading provider of waterjet cutting systems with its offices in Eben im Pongau, Austria, and Schweinfurt, Germany. For more than 25 years the service specialist has been developing future-proof production solutions, mainly for the steel, aluminium, metal, plastic, stone, composite materials and glass industries.

The modular portal systems cover all cutting tasks in the 2D and 3D sectors which are currently possible and are most notable for their efficiency and flexibility.

STM customers value ease of use and personal advice. Cost optimization and energy savings are particularly in focus.

The precise adaptation to customer requirements and their individual production processes enables STM to keep the total cost to the customer low. With the STM "Construction Kit"-System the customer gets everything he needs and nothing he does not need. This saves costs and space.



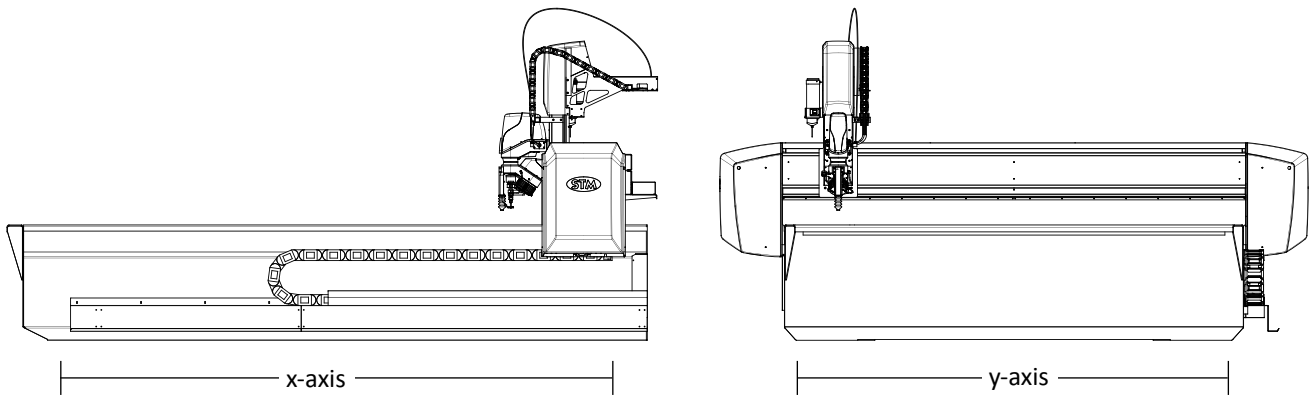

Technical specifications

Workspace	min. 1 m x 1 m / Vertical format: max. 6,5 m x 2,5 m / Horizontal format: max. 2 m x 4 m
Travel speed	up to 60 m/min
Positioning accuracy	± 0.02 mm (per metre at 20°)
Repeat accuracy	± 0.01 mm (per metre at 20°)
Z-axis clearance	300 mm / 600 mm / 900 mm
A-axis feed	360 deg./sec.
C-axis feed	360 deg./sec.

Included in the PremiumCut package

- ▶ Welded rust-proof machine frame of aluminium and stainless steel
- ▶ Brushless servomotors
- ▶ Premium guide X & Y-axis with Bosch Rexroth™ with high-precision ball bearing carriage and stainless steel balls
- ▶ Heavy-duty load supports for workpieces of up to 1.000 kg/m²
- ▶ CNC control unit and PC user interface
- ▶ Control console
- ▶ Marking of workpieces standard
- ▶ STM SmartCut waterjet software
- ▶ 3D cutting head or 2D cutting head
- ▶ Automatic height sensing Z-axis
- ▶ STM Edge Tracker positioning laser
- ▶ High pressure pump on the pressure intensifier principle between 11/75 kW, 4.000/6.000 bar depending on requirement
- ▶ Waterjet cutting valve
- ▶ Abrasive cutting head
- ▶ Abrasive dosing device manual sand quantity control 0-1.000 g/min
- ▶ Supply tank for 250 kg abrasive medium

Tuning options

- ▶ Additional cutting heads 2D/3D
- ▶ Additional CNC Z-axes 2D/3D with cutting head incl. abrasive equipment
- ▶ STM pipe cutting module
- ▶ Predrilling unit pneumatic or electric
- ▶ Water level control for cutting tank
- ▶ Pressure bag filter
- ▶ Automatic abrasive recovery
- ▶ Supply tank for 1.600 kg abrasive medium
- ▶ STM OneClean - all-round system for recycling and cleaning abrasive and water
- ▶ Adjustable feet for cutting tank

STM Stein-Moser GmbH
WATERJET SOLUTIONS

Gewerbegebiet Gasthof Süd 178 T: +43 (0) 64 58/200 14-0 W: www.stm.at
5531 Eben im Pongau, Austria E: info@stm.at UID: ATU 35291607

Subject to technical modifications and error. STM 10/2017