



COMPRESSORS AND COMPRESSED
AIR TECHNOLOGY





Production and administration building at Hohenzell/Austria

Dear customers,

There are many good reasons for taking a close look at this catalogue!

In 1992, we founded AIRCRAFT Kompressorenbau GmbH, because there were no compressors that met our requirements and expectations on the market at the time. We thus decided to produce our own compressors to meet our requirements in terms of equipment level, convenience and user-friendliness, and to offer the user the best possible price/performance ratio at the same time.

As early as the company's founding year our products were way ahead of their times. We had developed an innovative compressor, in the form of the **duo-airmat**, and we had patented the design, whose features some competitors were still presenting as innovations 15 years later. We have regularly set new standards ever since these early days, extending our product and service portfolio.

This also gives you the ability to additionally order the installation of your compressed air system, including installation of the pipe network, as a turn-key system from a single source. AIRCRAFT is also happy to design your complete system on request, and we ensure that it is installed in good time and to your complete satisfaction. On top of this, our Field Service Team is happy to provide extended support for your projects, helping you to use energy in a meaningful way, and thus achieve constantly high efficiency with your system. Reduce your energy, wear and maintenance costs with our efficient screw-type and piston compressors and save money in the process.

We owe this progress to a large extent to you, our customers. Your feed inspires our engineers to embrace new approaches, and thus continually enhance our products and services. And this is something that we very much appreciate.

You will find the latest news and further innovations on our websites at www.aircraft.at and www.aircraft-kompressoren.de.

Browse our online catalogues, build up expertise with our advanced product movies, and find a local dealer with just a few clicks.

Please do not hesitate to contact us with your questions regarding compressed air.

We look forward to seeing you!

Your AIRCRAFT Team

Kilian Stürmer
Managing Director

Klaus Hütter
Managing Director



Sales and service Germany in Hallstadt / Bamberg / Germany



Innovation is our tradition.



AIRCRAFT in the STÜRMER Group

Aircraft is a punch-packing business in the company group with STÜRMER Maschinen; it benefits from shared pan-European sales, service and logistics.



■ Ahead of its time back then:
the AIRCRAFT duo-airmat (1992)



DISCOVER OUR PRODUCT VIDEOS NOW!

All of our product videos are available for you to watch on our **Stürmer Maschinen GmbH (English channel)** YouTube channel. **Subscribe** to our YouTube channel, to avoid missing any of the new videos.



SLD Logistics Centre



In early April 2014, operations started in our new logistics centre. At the company site in Pettstadt near Bamberg (15 km from head office) with some 50 000 m², the new logistics centre was created with 20 000 m² of hall floor space: another milestone in the history of the STÜRMER Group.

The objective was to improve delivery quality in all respects, and thus offer our esteemed business partners tangibly increased benefits.

Today, the new processes are established to the extent that the value chain works in a trouble-free way.

Our objectives are your benefits!

Our logistics centre stocks more than 360 000 articles. This allows for fast shipment of almost all of our products to Germany and throughout Europe. Qualified staff ensure the orderly delivery of the goods. Every year, more than 100 000 items leave the company's premises, with our own delivery vehicles, by carrier, or by parcel service.

The SLD STÜRMER Logistics Centre:

- Own fleet of five trucks
- 20 000 pallet bays
- 2 500 bays for small parts
- 22 000 m² of warehouse space
- 52 qualified warehouse clerks and trainees
- Approx. 9 450 shipments per month
- Approx. 20 m euro worth of goods in stock at all times

More than 500 000 items ready for delivery:

- Around 21 000 machines
- Around 235 000 accessories
- Around 250 000 spare parts
- (Valid as of 1 August 2018)**

The most important success factors

- › Rapid availability thanks to high storage capacity
- › Fast loading and turn-around times thanks to storage bay management and path optimisation
- › Ensured quality thanks to scanner-based methods
- › Huge improvement in the permeability of the outgoing goods process



Air compressors



22 000 m² of warehouse space





STÜRMER demonstration and training centre

At our newly opened demonstration centre at our main facility in Hallstadt, near Bamberg, you can experience many of our highlights live on a floor space of some 2 000 m². Four customer advisors are available to help you with their expert knowledge.

What you can look forward to

Approx. 2 000 m² of training and exhibition floor space

- ▶ 150 machines permanently available to demonstrate to you
- ▶ An excerpt of the most important machines from each sector of our product portfolio

STÜRMER also provides product training for its retail partners at our company headquarters in Hallstadt.

At our specially equipped training and presentation rooms, retailers learn the key facts about STÜRMER products, and the unique selling points compared with third-party products.

Many machines are presented, demonstrated and explained in our exhibition space. Hands-on training is guaranteed.



Up to 60 persons can be brought along to dealer-specific meetings and training sessions.



The company's own bistro for a cosy way to wind up meetings, discussions and training sessions.



"With brand-name products from the STÜRMER Group, you can always be sure of making the right purchasing decision."

A price comparison among genuinely equivalent and comparable products offers you the assurance that purchasing a brand-name product by STÜRMER gives you a product that stands comparison in terms of ease of use, features, quality, engineering and price-performance and the right purchasing decision for you.

Expert advice before buying, after-sales service and a reliable supply of spare parts after purchase, protect the STÜRMER customer's investment for many years.

Quality at an attractive price!

Your requirements are our target



Our designs reflect practical requirements.



State-of-the-art precision compressor manufacturing

■ Planning

As early as the planning phase our engineering department becomes involved in the development of new products, which are manufactured both our facility and facilities operated by our partners. This ensures that market factors and customer requirements are immediately into our workflow, setting the stage for a successful product design.

■ Future-oriented development

AIRCRAFT products are always in a forward-looking development workflow. Our development work relies on state-of-the-art 3D CAD software, which we use to create a virtual model of the machine. Besides ensuring optimum functionality, our development process also targets re-usability of the data.

■ Production and supplier support

At AIRCRAFT, we produce the lion's share of our compressors at our own production facility in Austria. Regular work meetings between our engineers help to transfer new developments and enhancements into series production at the manufacturing location in a targeted way. This direct support at our production facilities has been indispensable in manufacturing the quality products that our customers have trusted for more than 20 years.

■ Hands-on testing

Our technicians' engineering expertise combines theory and practice. To avoid leaving anything to chance in terms of product satisfaction, all of our machines and tools go through application engineering tests. This means that each new product is expected to prove itself in the daily grind before it comes a fixed part of our product range. Engineering analysis helps us to discover and eliminate any remaining weak points.



Fully automated series production ...



for uncompromising product quality.



State-of-the-art precision compressor manufacturing

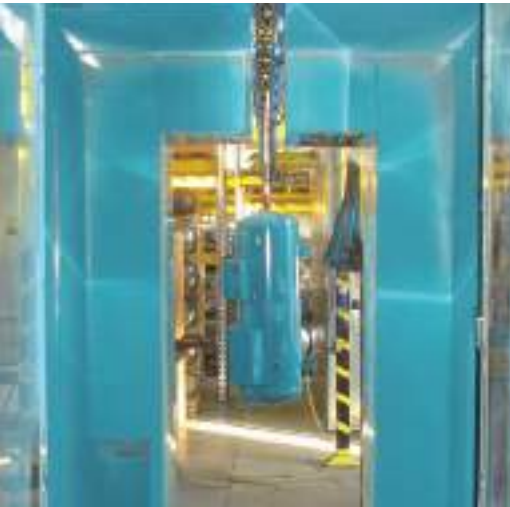

Environmentally-friendly powder coating plant



Hot-dip galvanisation for a long service life



Our compressor assembly line

■ Quality assurance

Quality tests with a continuous documentation are the basis for consistently high product quality. We thus encourage premium quality thinking in all of company's departments. Regular tests are an indispensable part of our quality assurance system. Qualified employees with electrical, safety and application engineering skills test the products in line with clearly-defined test specifications.

PROFESSIONAL AIRCRAFT SERVICE - FOUR BUILDING BLOCKS FOR YOUR BENEFIT

1 Inventory and requirements analysis

We support you in your efforts to achieve an efficient compressed air system that perfectly reflects your needs. You can benefit from the following services: determination of your compressed requirements, leakage dew point, pressure dew point or flow rate measurements, and a comprehensive engineering and safety check. We are happy to take care of leak finding, and perform energy efficiency measurements.

3 Installation and commissioning

The AIRCRAFT service field force, and our service partners, ensure reliable, nationwide, on-site service for our customers. This also includes installing and commissioning your compressed air system and the complete pipe network. In the scope of your order, we also handle the installation of the compressed air lines, and ensure that they are installed in good time and to your complete satisfaction.

2 Advisory services and system planning

Are you planning a new factory building, looking to overhaul existing workplaces, planning an extension or modernisations?

4 Maintenance and repairs

Our service protects your investment in machinery for years. For service cases, you can call in our experienced AIRCRAFT engineers and your local specialist retailer. Our well-stocked spare parts warehouse guarantees rapid delivery of replacement parts when needed. And if your compressor should happen to fail, many of our sales partners will provide you with a substitute compressor for the duration of the repairs.

Nationwide sales in Germany

Your contact

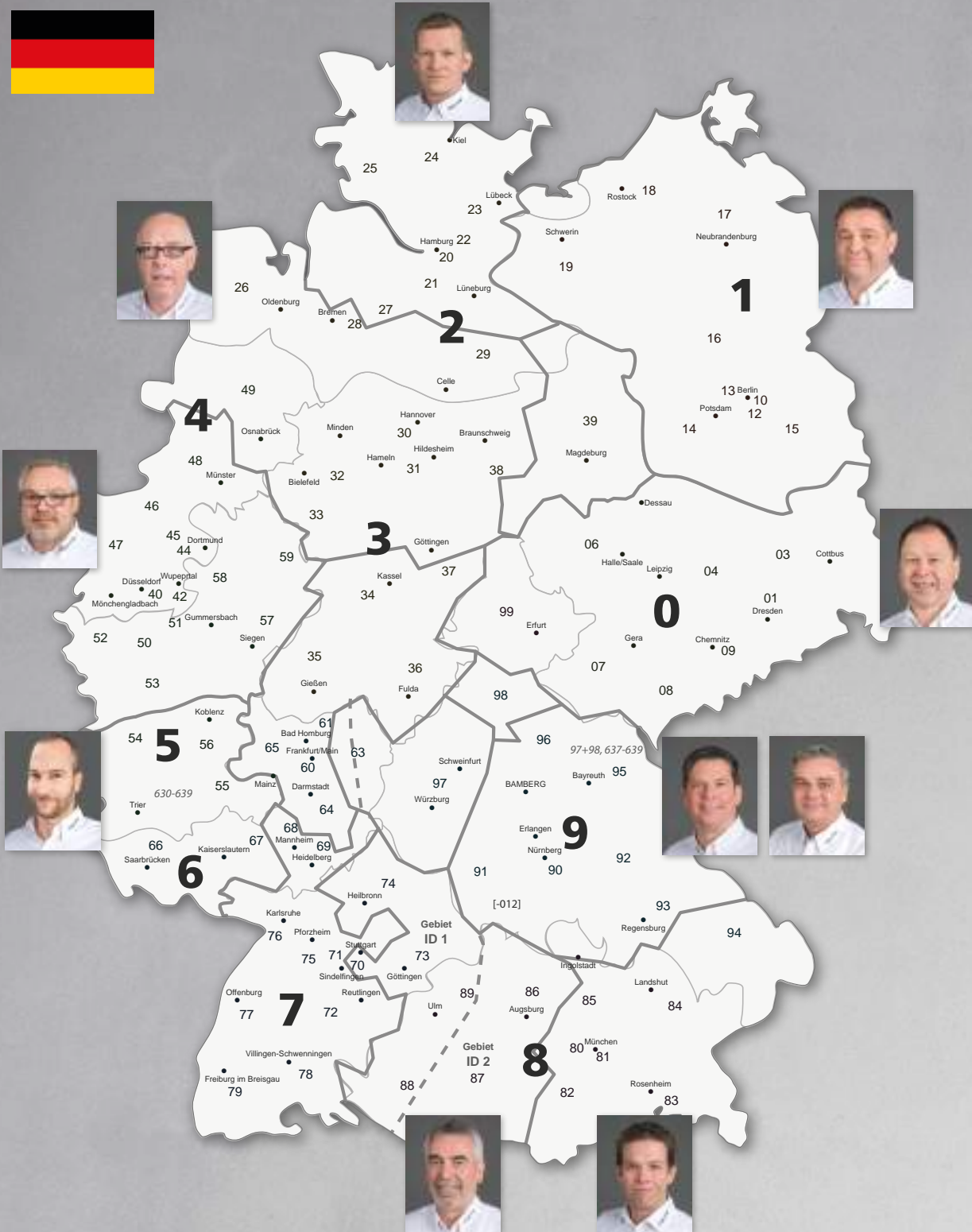

 **COMPRESSED AIR ADVISORY SERVICE**
AIRCRAFT GERMANY:

 Phone: +49 (0) 951 - 96 555-0
Email: info@aircraft-kompressoren.de

 **SERVICE HOTLINE**
(REPAIRS, WARRANTY CLAIMS)

Phone: +49 (0) 951/96 555 - 100 · Fax +49 (0) 951/96 555 - 111
Email: service@stuermer-maschinen.de
Fast order processing & status queries: 24h via our Partner Portal
Our specialist retail partners can contact us as follows:
Monday to Thursday: 7 am to 5 pm, Fridays 7 am to 4 pm

ONLY FOR SPECIALIST RETAIL PARTNERS

 **HOTLINE SPAR PART ORDER**

 Jürgen Temschenko
Phone: +49 (0) 951/96 555 - 118
Fax: +49 (0) 951/96 555 - 119
Email: ersatzteile@stuermer-maschinen.de



Phone: +43 (0) 7752 - 70 929-0
Email: info@aircraft.at



The AIRCRAFT maintenance agreement - your benefits



Our expert service team - competent and committed

■ Professionally performed maintenance

Trained service staff performs maintenance, using only AIRCRAFT spare parts.

■ Operating capability you can rely on

Minimising repair costs and maintaining the operating safety through regular maintenance.

■ Reducing operating costs

Potential defects and wear are identified at an early stage. This protects our customers' investment against unnecessary, expensive repairs and avoidable downtime.

■ Cost transparency

Working time and travel are invoiced by maintenance interval at the agreed rate, plus the agreed material costs.

■ Optimising and protecting your investment

Regular maintenance of compressed air systems preserves their functionality, maximising efficiency and maintaining their value in the long term.

■ Minimising administrative overhead

Maintenance is coordinated by our service team at regular intervals.

STÜRMER Support

Today, STÜRMER Maschinen employs around 250 group staff at its Hallstadt facility. Some 50 experienced and appropriately qualified service staff are also available to customers, from the technical hotline, through spare parts logistics to service calls at the customer site.

At the Service Centre, incoming customer requests are processed directly, or distributed to the appropriate departments. The adjacent comprehensive spare parts warehouse ensures rapid delivery of spare parts in case of need.

We understand that customers' need a competent partner who is available to quickly and efficiently find a solution; and we implement these solutions every day at the Service Centre. At the centre alone, we employ 14 master craftsmen from the fields of electrical engineering, electronics, automotive mechanics, mechanical engineering and mechatronics.

■ The complete "package deal" by AIRCRAFT: Planning and installing your compressed air system



... for more details, please refer to page 10



Engineering hotline

1 Forward-looking investment

When buying a compressor, do not focus on your current needs. Instead, consider intended future use and then decide on correct dimensioning.

2 Intake performance

The intake capacity is not equivalent to the air flow that is actually available. Please only consider the compressor's output, and make sure that you have planned for an adequate output reserve before purchasing a compressor. A good balance between fill capacity and air consumption guarantees the best possible results.

3 Volume of air

The air flow is driven by your requirements. It is the total consumption by tools, machines and other compressed air devices. When computing this value, you need to consider the compressor's capacity and the workload for which you will be deploying the compressor.

4 Working pressure

To be able to design your new compressor, it is important to determine the correct working pressure of your tools and machines. Excessive operating pressures do not translate to efficiency, but they do increase compressed air consumption, operating costs and wear on your machines.

5 Equipment level

AIRCRAFT compressors are richly equipped as a factory standard. On top of this, we offer a comprehensive range of accessories. The exact equipment features are described on the following pages in the "Technical data" boxes; accessories are referenced separately.

6 Compressed air quality

Inadequately treated compressed air which is soiled with particles, humidity and oil increases the susceptibility of your compressed air devices and machines to failure. This results in increased wear and performance losses. On top of this, inadequately treated introduces contamination into your working process, and this can result in expensive reworking, for example, in painting work.

7 Compressor rooms and installation

Our AIRCRAFT compressed air stations provide a perfect solution on a small footprint. The heat generated by the compressor needs to be dissipated. This means creating sufficiently dimensioned intake and exhaust air openings.

8 Compressor capacity utilisation

In case of continuous compressed air consumption, we recommend an AIRCRAFT screw-type compressor designed for 24x7 operation. If your compressed air needs are sporadic, an AIRCRAFT piston compressor will typically be the better choice. But you can also combine both systems to account for peak loads.

9 Sound pressure level and sound power level

We state both the sound power level L_{wA} and the sound pressure level L_{pA} for our compressor's noise levels. To prove that these values are incompatible, and cannot be compared at face value with other noise levels, e.g. for aircraft, please read the short explanation on how to determine the two values below.

• Sound pressure level L_{pA}

Volume is defined as a separate value by the sound pressure or by the logarithmic sound pressure level. The sound pressure describes the actual effect of a sound source on the air pressure and thus on human hearing. It is measured directly and always depends on the distance to the sound source and the acoustic conditions in the room. The sound pressure level is the value used to assess occupational safety and health protection (in the sense of the Occupational Health and Safety Ordinance).

• Sound power level L_{wA}

The sound power describes the sound energy emitted by a sound source over a unit of time. It can be determined by measuring the sound pressure at several places on an enclosed enveloping surface around the sound source. This value is not measured directly but computed; it does not depend on the distance or the acoustics of the room. The sound power level serves, for example, to define legal limit values for the use of devices outdoors (Outdoor Directive).

10 Determining your compressed air requirements

Most work tasks are only temporary. You can compute the average on-period for these. On top of this, most consumers are not generally used at the same time. The average on-period and the simultaneous use factor f need to be considered in your computations to reduce the total requirement.

























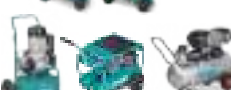

















Total compressed air consumption: when dimensioning your compressor you also need to take the following factors into consideration: leakage loss, reserves and incorrect forecasts.

Sample computation, compressed air requirement:

Compressed air consumers	Working pressure (bar)	Duty cycle DC (%)	Number A (units)	Individual consumption q (l/min.)	A x q x DC/100 (l/min.)
Paint gun Ø 1.5 mm	3	40	1	180	72
Blow-out gun Ø 1.5 mm	6	10	3	65	19.5
Impact driving tool M 10	6	20	3	200	120
Drill up to Ø 20mm	6	30	1	700	210
Angle grinder	6	40	2	500	400
Sum total Q of compressed air consumption by consumers				(l/min)	821,5
Simultaneity factor f					0.71
Compressed air consumption of consumers $Q_f = f \times Q$				(l/min)	583.3



"A program that leaves nothing to be desired!"

Piston compressors	16				
AIRBOY series	20		AIRPROFI DUO series 13 bar stationary 13-15 bar	64	
AIRBOY E series	22		AIRPROFI BK series auxiliary compressors stationary 13 - 15 bar	66	
HANDY E series	22		AIRPROFI Silent mobile series	68	
MOBILBOY E series	22		AIRPROFI SILENT series stationary 10 and 15 bar	70	
AIRBOY SILENCE OF E series	24		Screw-type compressors	72	
COMPACT-AIR OF E series	24		ACS power unit	74	
MOBILBOY E / F series	26		ACS mobile series	75	
COMPACT-AIR/COMPACT-AIR E series	28		ACS stationary series	76	
COMPACT-AIR BX PRO series	32		ACS Duo series	78	
COMPACT-AIR PRO series	34		ACS AIRCAR	80	
AIRCAR PRO series	36		EASY X4 sequence controller	84	
AIRBAU/AIRCAR-BAU series	38		A-MICRO SE series 2.2 – 4 kW	88	
AIRSTAR E Series	40		A-DUO-MICRO series 4 kW	90	
AIRSTAR Series	46		A-MICRO series 4 – 5.5 kW	92	
AIRPROFI mobile series	48		A-PLUS series 7.5 – 11 – 15 kW	96	
AIRSTAR stationary series 10 bar	52		A-PLUS series 18.5 – 22 kW	98	
AIRPROFI V stationary upright series 10 bar	54		A-PLUS series 30 – 75 kW	100	
AIRPROFI H stationary horizontal series 10 bar	56		LongLifeKits A-PLUS / A-MICRO	102	
AIRPROFI Duo stationary series 10 bar	58		A-K-MAX 5.5 - 22 kW	110	
AIRPROFI BK auxiliary compressors stationary series 10 bar	60		K-MAX VS 7.5 kW – 37 kW	112	
AIRPROFI Series stationary upright 13-15 bar	62		LongLifeKits A-K-MAX	114	
AIRPROFI Series stationary horizontal 13-15 bar	63		HRS series (heat recovery)	118	
			Compressed air system components	120	
			Compressed air batteries/vessels	121	
			Ball valves/energy saving devices	133	

Switches/valves/motor protection/
manometers/lines/sealing tape/screw
locking 134



Motors and accessories/compressors/v-
belts/impellers 136



Compressed air maintenance units 138

Compressed air maintenance units per-
fectly planned 140



Electronic condensate drain 142



Water trap / compressed air filter 146



Compressed air filter 148



Compressed air refrigeration dryer 152



Compressed air distribution 154

Compressed air line systems 156



Compressed air starter kit 163



Plastic pipes Ø 15-28 mm 163



Aluminium pipes Ø 15-32 mm 163



Pipeline building components Ø 15-32
mm 164



Pipe network components 166



Pressure regulators/maintenance units 172



Compressed air fittings 174



One-handed safety couplings 176



Compressed air tools and accessories 179

Air brush sets and paint spray guns 180



Blow guns 182



Tyre inflator and pressure gauge 186



Compressed air kits 187



Cartridge guns 188
Grease guns
Spray guns
Underbody protection gun



Sandblasting guns 190



Impact driving tools 191



Drilling machine / Screw driver 196



Grinding tools 198



Cutters, cutting and stamping tools 204



Grinding/polishing machines & special
cutters 205



Riveting tools 206



Compressed air panel-beating hammer 206



Saws 207



Needle scalars 207



Chisel hammer drills 208



Lubricants/Oil 209



Clamping and nailing tools 210



Power modules 211



Compressed air hoses 212



Spring balancers 213



Hose rewriter 214



Cable reel 215



UNICRAFT sandblasting cabinets 216



Piston compressors or screw-type compressors?

The fundamental decision when installing a compressor station is that of choosing the right type of compressor. Both compressor systems have their specific advantages:



PROS: PISTON COMPRESSORS:

Intermittent demand

- ▶ Piston compressors are suitable for fluctuating compressed air consumption with peak demands. They can be used as peak load machines in a compressor array. Piston compressors are the best choice for frequently changing load cycles.
- ▶ Piston compressors have an intermittent **duty cycle**, without idling.

Low delivery volumes

- ▶ If the delivery volumes are low, the piston compressor is a more cost-efficient choice than the screw-type compressor.
- ▶ Piston compressors can compress to high **final pressures** (8 bar, 10 bar, 15 bar, 30 bar and 35 bar)*

*Piston compressors with operating pressures of 30 bar and 35 bar on request.

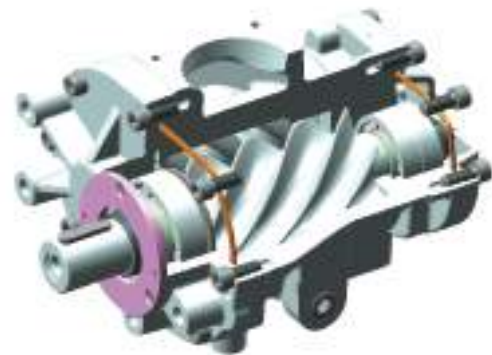

PROS: SCREW-TYPE COMPRESSORS:

Long duty cycle

- ▶ Screw-type compressors are specially designed for use in continuous compressed air consumption without high peak demands
- ▶ (duty cycle = 100%). They are an excellent choice of machine for handling the basic load in a compressor array.

High delivery volumes

- ▶ The screw-type compressor is the most economical choice if you need a high delivery volume.

Pulsation-free volume flow

- ▶ Due to its uniform compression, the screw-type compressor can also be used for very sensitive compressed air consumers.

- ▶ Screw-type compressors work most economically at **compression pressures** of between 5 and 14 bar.

- ▶ Virtually **vibration-free** and **very quiet**
- ▶ State-of-the-art control technology



Conclusions

If you anticipate **fluctuating compressed air consumption** in your operations, and will not be extending the system until later, a **piston compressor** is your best choice.

If you have a **constant and high compressed air requirement for the most part**, you are better served with a **screw-type** compressor.

The choice of the correct system should not depend on the purchasing price, since it will rapidly pay off through savings on operating costs. On-going **operating costs** do not just include energy costs for generating compressed air, but also **idle mode and maintenance cost**.

Which AIRCRAFT piston compressor is the right choice for my application?

Compressor/Model	Page	Sealing	Drilling	Painting/ Preserving			Chiselling			Stapling	Nailing	Inflating tyres Measuring	Cleaning Blow cleaning	Screws Changing tyres			Grinding/cut- ting/ Sand blasting	Spraying
				●	○	—	●	○	—					●	○	—		
AIRBOY SILENCE 50 PRO	21	●	—	●	○	—	—	—	—	○	○	●	—	—	—	—	●	
AIRBOY KIT 90	21	●	—	●	●	—	—	—	—	●	○	●	—	—	—	—	●	
AIRBOY 261 E	21	●	—	●	●	—	—	—	—	●	○	●	—	—	—	—	●	
AIRBOY SILENCE 40 OF PRO	22	●	—	●	—	—	—	—	—	●	○	●	—	—	—	—	○	
AIRBOY 186 OF E	22	●	—	●	●	—	—	—	—	●	○	●	—	—	—	—	○	
AIRBOY 206 OF E	22	●	—	●	●	—	—	—	—	●	○	●	—	—	—	—	○	
HANDY 201 OF E	22	●	—	●	●	—	—	—	—	●	○	●	—	—	—	—	●	
MOBILBOY 221/24 OF E	22	●	○	●	●	—	—	—	—	●	○	●	—	—	—	—	●	
MOBILBOY 241/24 E	22	●	○	●	●	—	—	—	—	●	○	●	—	—	—	—	●	
MOBILBOY 241/50 E	22	●	○	●	●	○	○	—	—	●	○	●	—	—	—	—	●	
MOBILBOY 185 OF E	23	●	—	●	●	—	—	—	—	●	○	●	—	—	—	—	○	
AIRBOY SILENCE 50 OF E	25	●	—	●	○	—	—	—	—	○	○	●	—	—	—	—	●	
AIRBOY SILENCE 100 OF E	25	●	—	●	●	—	—	—	—	●	○	●	—	—	—	—	●	
COMPACT-AIR 240/20 OF E	25	●	○	●	●	○	○	—	—	●	○	●	—	—	—	○	●	
MOBILBOY 301/24 E	26	●	○	●	●	○	○	—	—	●	○	●	—	—	—	—	●	
MOBILBOY 311/50 E	26	●	○	●	●	○	○	—	—	●	○	●	—	—	—	—	●	
MOBILBOY 361/50 E	26	●	●	●	●	○	○	○	○	●	●	●	—	—	—	○	●	
MOBILBOY 301/24 F	27	●	○	●	●	—	○	—	—	●	○	●	—	—	○	—	●	
MOBILBOY 311/50 F	27	●	○	●	●	○	○	—	—	●	○	●	—	—	○	—	●	
COMPACT-AIR 221/10 E	29	●	○	●	●	—	○	—	—	●	○	●	—	—	○	—	●	
COMPACT-AIR 265/10 E	29	●	○	●	●	—	○	—	—	●	○	●	—	—	○	—	●	
COMPACT-AIR 311/20 E	31	●	○	●	●	○	○	—	—	●	○	●	—	—	○	—	●	
COMPACT-AIR 321/20	31	●	●	●	●	○	○	—	—	●	●	●	—	—	—	○	●	
COMPACT-AIR 361/20 E	31	●	●	●	●	○	○	○	○	●	●	●	—	—	—	—	●	
COMPACT-AIR BX 240 SILENT	33	●	●	●	●	○	○	—	—	●	●	●	—	—	—	○	●	
COMPACT-AIR BX 330 OF PRO	33	●	●	●	●	○	○	—	—	●	●	●	—	—	—	○	●	
AIRCAR BX 330 OF PRO	33	●	●	●	●	○	○	—	—	●	●	●	—	—	—	○	●	
AIRPROFI BX 660/100 OF PRO	33	●	●	●	●	○	○	—	—	●	●	●	—	—	—	○	●	
COMPACT-AIR 425/20 E	35	●	●	●	●	○	○	○	○	●	●	●	—	—	—	○	●	
COMPACT-AIR 321/24 PRO	35	●	●	●	●	○	○	—	—	●	●	●	—	—	—	○	●	
AIRCAR 321/22 PRO	37	●	●	●	●	○	○	—	—	●	●	●	—	—	—	○	●	
AIRCAR 553/22 PRO	37	●	●	●	●	●	●	○	○	●	●	●	—	○	—	—	●	
AIRBAU 652/100 B PRO	39	●	●	●	●	●	●	●	●	●	●	●	—	—	—	○	●	
AIRCAR-BAU 650 B PRO	39	●	●	●	●	●	●	●	●	●	●	●	—	—	—	○	●	
AIRSTAR 321/50 E	41	●	●	●	●	●	●	○	—	●	●	●	—	—	—	○	●	
AIRSTAR 401/50E 403/50 E	41	●	●	●	●	●	●	○	—	●	●	●	—	—	—	○	●	
AIRSTAR 401/50 403/50	46	●	●	●	●	●	●	○	—	●	●	●	—	—	—	○	●	
AIRSTAR 503/50	46	●	●	●	●	●	●	○	—	●	●	●	—	—	—	○	●	
AIRSTAR 503/100	46	●	●	●	●	●	●	○	—	●	●	●	—	○	—	—	●	
AIRSTAR 703/100	47	●	●	●	●	●	●	●	●	●	●	●	—	—	—	—	●	
AIRSTAR 853/100	47	●	●	●	●	●	●	●	●	●	●	●	—	—	—	—	●	
AIRSTAR 853/200	47	●	●	●	●	●	●	●	●	●	●	●	—	—	—	—	●	
AIRPROFI 401/50 403/50	48	●	●	●	●	●	●	○	—	●	●	●	—	—	—	○	●	
AIRPROFI 503/50	48	●	●	●	●	●	●	○	—	●	●	●	—	—	—	—	●	
AIRPROFI 503/100	48	●	●	●	●	●	●	○	—	●	●	●	—	○	—	—	●	
AIRPROFI 703/100	49	●	●	●	●	●	●	●	●	●	●	●	—	—	—	—	●	
AIRPROFI 853/100/10	49	●	●	●	●	●	●	●	●	●	●	●	—	—	—	—	●	
AIRPROFI 853/200	49	●	●	●	●	●	●	●	●	●	●	●	—	—	—	—	●	
AIRPROFI 703/75/13	49	●	●	●	●	●	●	●	●	●	●	●	—	—	—	—	●	
AIRPROFI 703/100/15	49	●	●	●	●	●	●	●	●	●	●	●	—	—	—	—	●	
AIRSTAR 703/270/10 H	52	●	●	●	●	●	●	○	—	●	●	●	—	○	—	—	●	
AIRSTAR 703/270/10 V	52	●	●	●	●	●	●	○	—	●	●	●	—	○	—	—	●	
Stationary compressors	as of 73	●	●	●	●	●	●	●	●	●	●	●	—	—	—	—	●	
<ul style="list-style-type: none"> ● best suited ○ restrictions apply — not suitable 		Cartridge gun PRO, Cartridge gun PRO KP, Silicone caulking gun	BM R+L PRO	Air-Brush kit AS	Decoration gun ES	Paint spray guns: SD, RD, PJ HVL P, HVL P PRO Underbody protection guns	Chisel hammer sets: MHU, MHM, MHB	Chisel hammer for demolition work MHA PRO	Chisel hammer for demolition work MHP PRO	Clamping devices: KG 16 PRO, KG 32 PRO, NKG 40/50 PRO, KG 50 PRO	Nailing device NG 90	Tyre inflator and pressure gauge SD, SD-G, PRO, PRO-G	Blow guns: BPK, BPL, PRO L, PRO XL, PRO XXL, PRO V, PRO G, BPI PRO, Soft BPS	Industrial impact screw driver ISS 1"	Ratchet screw driver: 1/4" PRO, 1/2" LR S, 1/2" LR PRO	Impact screw driver: SS S 1/2", ISS 1/2", ISS 3/4"	Grinders, universal saws, steel sheet nibblers, sandblasting guns	Spray gun aluminium

These indications serve for orientation and are non-binding. Depending on your individual choice and use of a compressed air tool, your compressed air requirements can be different or higher.

Model series overview

AIRCRAFT piston compressors - the right compressor for every application.

Entry-level models

Our models for entry-level compressor technology needs. Perfect for households, DIY and occasional use on building sites wherever there is no need for a permanent compressed air supply.

Oil-free models also available.

Our Economy models are available at very attractive prices!

Building site professionals

A variety of direct drive or belt-driven models in different power classes (8 to 14 bar maximum pressure). For professional use in industry and trade. For any task and for any application. This model series also impresses with a choice of form factors that offer you the convenience you need in different work areas. All of them come with a complete feature set. Simply connect and work.

Rugged, belt-driven compressors for builders, decorators and DIY

Rugged compressors with a tried-and-trusted belt drive and 2-cylinder, aluminium high-performance units - quality for builders, decorators and demanding DIY enthusiasts.



Economy Line
AIRBOY
COMPACT-AIR
MOBILBOY



COMPACT-AIR
COMPACT-AIR PRO
AIRCAR-BAU



AIRSTAR Series

Mobile professional compressors with a maximum feature set for builders and decorators

The AIRPROFI series is used by professionals and, in particular, by demanding users. AIRPROFI stands for compressors with an extremely rugged design capable of handling demanding daily use in building and other trades. Premium workmanship and features as a factory standard guarantee the durability of all the compressors in the AIRPROFI series.



AIRPROFI Series

Stationary equipment - maximum performance on a small footprint

Maximising the compressed air availability with tank sizes up to 500 l. Also with an bolted-on refrigerant type dryer, microfilter, condensate conditioning unit and condensate drain as a space-saving complete compressed air unit. Your complete compressed air generation system with premium compressed air treatment on a footprint of just 1 m².



**AIRPROFI BK
AIRPROFI V / H
AIRPROFI Duo**

AIRPROFI Silent - compressors with noise-insulating housings

Extra silent. Perfect for direct deployment in work areas where, e.g., a separate compressor room is not available.



**Airprofi Silent series
versions:
mobile or stationary, with or
without a pressure vessel**

AIRCRAFT piston compressor systems

WDS



Maintenance-free continuous-lubrication (WDS)

- ▶ In the WDS system, a Teflon piston ring replaces the standard steel piston ring
- ▶ This removes the need for mineral oil-based lubrication

“WDS” lubricating system benefits

- ▶ There is no need to check the oil level or change the oil
- ▶ Attractively-priced solution thanks to low numbers of simple components
- ▶ Maintenance-free
- ▶ Ideal solution for low compressed air requirements, e.g., for domestic and garden use

HDS



High performance continuous-lubricating system (HDS)

- ▶ Developed for demanding, continuous use wherever oil-free and clean compressed air is required
- ▶ **Large piston, movably mounted on bearings to offset the tumble motion, thus achieving up to 60 % improved performance compared with tilt piston systems**
- ▶ Cylinder faces with high-precision and micro smooth surface to ensure minimum friction
- ▶ The high-performance piston and/or piston ring made of a special mixture of graphite, Teflon and carbon has a substantially longer lifetime than a simple Teflon piston ring

“HDS” lubricating system benefits

- ▶ Up to 50 times the duty cycle and service life compared with standard, maintenance-free, tilt piston systems
- ▶ The large surface cooling fins in combination with the single-piece cylinder ensure optimum heat dissipation
- ▶ Maintenance-free
- ▶ Ideal wherever oil-free and clean compressed air is required in daily use

WDS



HANDY 201 OF E on p.22

MOBILBOY 221/24 OF E on p.22

HDS



AIRPROFI 321/100 OF Silent on p.18

HDS BX model



Patented Engineering!

HOS



HDS - High performance continuous lubricating system

- ▶ Developed for demanding, continuous use wherever oil-free and clean compressed air is required
- ▶ **Large piston, movably mounted on bearings to offset the tumble motion, thus achieving up to 60 % improved performance compared with tilt piston systems**
- ▶ **The piston action in the BX model is axial, like in a flat engine - patented technology for significantly reduced wear (see image top right)**
- ▶ The pistons move axially in special ceramic coated aluminium cylinder, like in a flat engine.
- ▶ This drastically reduces the wear on the seals.
- ▶ This removes the need for the frequent and expensive maintenance that has to be performed on legacy dry compressors.

“HDS” BX lubricating system benefits

- ▶ The patented oil-free compressor system with double piston and horizontal compression, like in a flat engine, substantially reduces the otherwise typical wear on oil-free compressors
- ▶ The large surface cooling fins in combination with the cylinder manufactured as a single piece ensure optimum heat dissipation.
- ▶ Maintenance-free
- ▶ Ideal wherever oil-free and clean compressed air is required in daily use

High-performance- oil lubricating-system (HOS)

- ▶ The precision-manufactured piston has a high-alloyed piston ring, an oil scraper ring and oil spreader ring which provide a seal to the cylinder wall
- ▶ The crankcase is filled with oil which is sprayed against the cylinder wall with each piston stroke
- ▶ The oil scraper ring cleans the oil-wetted cylinder wall in downward direction

“HOS” lubricating system benefits

- ▶ Optimum lubrication and an optimum seal at the same time
- ▶ Long service life and excellent reliability
- ▶ Low maintenance
- ▶ Ideal for professional applications with high air flow rates

HDS BX model



COMPACT-AIR BX 330 OF PRO and AIRCAR BX 330 OF PRO on p. 32

HOS



MOBILBOY Series on p.22

AIRSTAR Series starting on p. 40

AIRPROFI V Series starting on p.54

Mobile entry-level class



AIRBOY series – portable compressors for more flexibility in daily use

- ▶ E models: ideal entry-level air compressors in building and trades
- ▶ PRO models and KITT 90: ideal for deployment in demanding building and trade applications
- ▶ Quality electric motors with powerful torque
- ▶ Equipped with motor soft-start and motor protection switch
- ▶ Fully automatic On/Off operation
- ▶ Switch and fittings perfectly protected by tubular frame
- ▶ Powder coated compressed air tanks
- ▶ Rubberised carrier handle prevents slipping



AIRBOY Silence 50 PRO

- ▶ Optimised for a low volume applications such as, e.g., airbrushing work
- ▶ Extremely quiet operation due to the encapsulated design - only 43 dB(A), and thus trouble-free use, e.g., in apartments, offices, etc.
- ▶ The working pressure is infinitely variable via the standard filter pressure regulator with simultaneous separation of dirt, oil and condensate



AIRBOY KIT 90

- ▶ Low speed
- ▶ This reduces vibration and wear on the compressor components
- ▶ Vibration-damping rubber suction feet

AIRBOY 261 E

- ▶ Automatic pressure switch
- ▶ Ideal entry-level model
- ▶ Single-handed quick-release coupling
- ▶ Vibration-damping rubber feet



Premium filter pressure regulator for continuous adjustment of the working pressure, with simultaneous dirt, oil and condensate separation



Figure shows the AIRBOY KITT 90

- 1 Includes a pressure regulator for continuous adjustability of the desired working pressure
- 2 Two pressure gauges indicate the tank and working pressure
 - Switch and fittings perfectly protected by tubular frame
- 3 Equipped with an automatic pressure switch
- 4 AIRBOY KITT 90 with premium single-hand quick coupling as standard
 - AIRBOY 261 E with single-hand quick coupling



Model	AIRBOY SILENCE 50 PRO	AIRBOY KITT 90	AIRBOY 261 E
Art. no.	2000100	2001237	2001245
Compressor system*	encapsulated	HOS	HOS
Highest flow rate	50 l/min	85 l/min	260 l/min
Fill capacity approx.	33 l/min	49 l/min	170 l/min
Maximum pressure	8 bar	15 bar	10 bar
Tank capacity	9 l	2.4 l	2.4 l
Cylinders/stages	1/1	1/1	1/1
Speed	2 900 rpm	1 420 rpm	2 850 rpm
Motor output	340 W/230 V	0.6 kW/ 230 V	1.8 kW/ 230 V
Weight	21 kg	21 kg	22 kg
Dimensions (L x W x H)	320 x 320 x 480 mm	510 x 270 x 400 mm	510 x 270 x 400 mm
Sound power level L _{WA} **	43 dB(A)	85 dB(A)	97 dB(A)

*For a description of the compressor systems refer to p. 18 **Sound power level according to DIN EN ISO 3744 (RL 2000/14/EC)

Special oil for Airboy Silence 50 Pro

Type	Art. no.
Special oil (bottle 0.5 l)	2500016

Mobile compressors

HANDY E / MOBILBOY E / AIRBOY E series - Handy products for domestic and DIY use at up to 10 bar

MOBILBOY series – mobile compressors for trade applications

- ▶ Universally deployable in domestic and DIY use, all compressors in the MOBILBOY Series also for on-site applications
- ▶ Fully automatic On/Off operation

- ▶ Electric motor equipped with soft-start and motor protection switch
- ▶ One pressure gauge each for displaying the tank and working pressure (except AIRBOY 206 OF E)

- ▶ Powder coated compressed air tanks
- ▶ Plastic wheels at rear
- ▶ Rubber foot or rubber suction pads at front
- ▶ Mains cable length 1.8 m



Oil-free!

1



AIRBOY 186 OF E

- ▶ Easy to use and carry
- ▶ With vibration-damping rubber feet
- ▶ Oil-free piston compressor; removes the need for oil changes and avoids oil in the condensate
- ▶ Single-handed quick-release coupling
- ▶ Pressure regulator



Oil-free!

2



AIRBOY 206 OF E

- ▶ With vibration-damping rubber feet
- ▶ Oil-free piston compressor; removes the need for oil changes and avoids oil in the condensate
- ▶ Single-handed quick-release coupling
- ▶ Pressure regulator



Oil-free!

3



HANDY 201 OF E

- ▶ With oil-free WDS compressor⁽¹⁾
- ▶ No oil change required
- ▶ No oil in the compressed air and in the condensate



Oil-free!

4



MOBILBOY 221/24 OF E

- ▶ With oil-free WDS compressor⁽¹⁾
- ▶ No oil change required
- ▶ No oil in the compressed air and in the condensate

Model	1 AIRBOY 186 OF E	2 AIRBOY 206 OF E	3 HANDY 201 OF E	4 MOBILBOY 221/24 OF E	5 MOBILBOY 241/24 E	6 MOBILBOY 241/50 E
Art. no.	2001230	2001235	2001210	2002222	2002241	2002250
Technical specifications						
Compressor system*	WDS	WDS	WDS	WDS	HOS	HOS
Highest flow rate	180 l/min	180 l/min	179 l/min	200 l/min	200 l/min	200 l/min
Fill capacity approx.	90 l/min	90 l/min	110 l/min	110 l/min	102 l/min	102 l/min
Maximum pressure	8 bar	8 bar	8 bar	8 bar	8 bar	8 bar
Tank capacity	6 l	6 l	6 l	24 l	24 l	50 l
Cylinders/stages	1/1	1/1	1/1	1/1	1/1	1/1
Speed	3 400 rpm	3 400 rpm	2 850 rpm	2 850 rpm	2 850 rpm	2 850 rpm
Motor output	1.1 kW / 230 V	1.1 kW / 230 V	1.1 kW / 230 V	1.5 kW / 230 V	1.5 kW / 230 V	1.5 kW / 230 V
Weight	9.2 kg	9 kg	11.5 kg	24 kg	22.5 kg	29.3 kg
Dimensions (L x W x H) in mm	315 x 355 x 370	385 x 170 x 465	330 x 255 x 500	570 x 255 x 590	570 x 255 x 590	790 x 310 x 670
Sound power level L _{WA} **	97 dB(A)	97 dB(A)	91 dB(A)	94 dB(A)	93 dB(A)	93 dB(A)

*For a description of the compressor systems refer to page 18 **Sound power level according to DIN EN ISO 3744 (RL 2000/14/EC)



MOBILBOY 241/24 E

- ▶ Equipped with pressure regulator, single-handed, quick-action coupling and automatic pressure switch as factory standard



MOBILBOY 241/50 E

- ▶ Equipped with pressure regulator, single-handed, quick-action coupling and automatic pressure switch as factory standard

Piston compressor MOBILBOY 185 OF E – handy trolley model with oil-free air-end for universal deployment up to 10 bar.

Oil-free air-end

- ▶ No oil change required
- ▶ For best quality of work and a long service life of compressed air tools

User-friendly design

- ▶ Compact model and thus mobile and portable

- ▶ Rugged plastic wheels and pull-out handle for easy transport

- ▶ Practical storage tray integrated into housing
- ▶ Compartment for stowing the mains cable

Fully feature set

- ▶ One pressure gauge for working pressure

- ▶ One single-handed, quick-action coupling
- ▶ Pressure regulator for continuously adjustable setting of the working pressure

- ▶ Condensate drain valve on the compressed air tank



Oil-free!



Model	MOBILBOY 185 OF E
Art. no.	2001240

Technical specifications

Compressor system*	WDS
Intake capacity	180 l/min
Fill capacity	90 l/min
Maximum pressure	10 bar
Tank capacity	5 l
Cylinders/stages	1/1
Speed	3 400 rpm
Rating	1.1 kW
Supply voltage	230 V
Sound power level L _{WA}	97 dB(A)
Length x width x height	320 x 380 x 467 mm
Weight	12 kg

*For a description of the compressor systems refer to page 18 **Sound power level according to DIN EN ISO 3744 (RL 2000/14/EC)

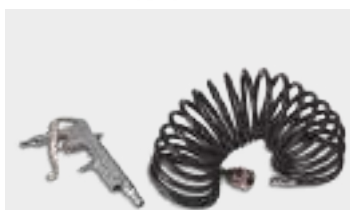

Scope of delivery MOBILBOY 185 OF E

- > Blow-out gun
- > 5 m spiral hose



- Rugged plastic wheels and pull-out handle for easy transport



- Compartment for stowing the mains cable



- Condensate drain valve on the compressed air tank

Airboy Silence mobile compressors

- ▶ Oil-free piston compressor; removes the need for oil changes and avoids oil in the condensate



Oil-free!

Control panel

- ▶ The ergonomically situated control panel is clearly structured and self-explanatory.
- ▶ One pressure gauge each for displaying the tank and working pressure
- ▶ Includes a pressure regulator for continuous adjustability of the desired working pressure
- ▶ With one take-off point for compressed air



Handle

- ▶ Rubberised carrying handle as factory standard, prevents slipping during transportation

- ▶ Electric motor equipped with soft-start and motor protection switch

- ▶ Vibration-damping rubber feet

Protection function

- ▶ The tubular frame provides optimal protection against damage to fittings.

Control panel

- ▶ The ergonomically situated control panel is clearly structured and self-explanatory.
- ▶ One pressure gauge each for displaying the tank and working pressure
- ▶ Includes a pressure regulator for continuous adjustability of the desired working pressure
- ▶ With two take-off points for compressed air

- ▶ Vibration-damping rubber feet



Handle

- ▶ Rubberised, folding carrying handle as factory standard, prevents slipping during transportation

Wheels

- ▶ The large stable wheels and the broad wheelbase provide for safe and comfortable transportation even on uneven surfaces

Airboy SILENCE OF E series - Handy products for domestic and DIY use at up to 10 bar
COMPACT-AIR 240/20 OF E – Handy mobile and oil-free universal compressor

- ▶ Electric motor equipped with soft-start and motor protection switch
- ▶ One pressure gauge each for displaying the tank and working pressure
- ▶ Powder coated compressed air tanks

Special features:

- ▶ Oil-free piston compressor; removes the need for oil changes and avoids oil in the condensate
- ▶ Single-handed quick couplings
- ▶ Pressure regulator
- ▶ Vibration-damping rubber feet



Oil-free!



Very quiet



Oil-free!



Very quiet



Oil-free!



AIRBOY SILENCE 50 OF E

- ▶ Small, compact design
- ▶ Extremely quiet operation



AIRBOY SILENCE 100 OF E

- ▶ Small, compact design
- ▶ Extremely quiet operation



COMPACT-AIR 240/20 OF E

- ▶ Sturdy wheels with full-rubber tyres
- ▶ Switch and fittings perfectly protected by tubular frame
- ▶ Compressed air outlet via two single-handed quick-action couplings

Model	Airboy Silence 50 OF E	Airboy Silence 100 OF E	Compact-Air 240/20 OF E
Art. no.	2000085	2000095	2005490
Technical specifications			
Highest flow rate	49 l/min	103 l/min	240 l/min
Fill capacity	28 l/min	55 l/min	170 l/min
Maximum pressure	8 bar	8 bar	8 bar
Tank capacity	4 l	4 l	20 l
Cylinders/stages	2/1	2/1	2/1
Speed	1 400 rpm	1 400 rpm	1 400 rpm
Rating	280 W	680 W	1.5 kW
Electrical connection	230 V / 50 Hz	230 V / 50 Hz	230 V / 50 Hz
Weight	11.1 kg	17.7 kg	41.4 kg
Dimensions (L x W x H)	360 x 355 x 310 mm	405 x 370 x 335 mm	785 x 510 x 475 mm
Sound power level $L_{WA}^{(2)}$	58 dB(A)	60 dB(A)	78 dB(A)

*For a description of the compressor systems refer to page 18 **Sound power level according to DIN EN ISO 3744 (RL 2000/14/EC)

Mobile compressors

MOBILBOY series – mobile compressors with up to 10 bar for trade applications

- ▶ Universally deployable in domestic and DIY use, also for on-site applications
- ▶ Fully automatic On/Off operation
- ▶ Electric motor equipped with soft-start and motor protection switch
- ▶ One pressure gauge each for displaying the tank and working pressure
- ▶ Powder coated compressed air tanks
- ▶ Plastic wheels at rear
- ▶ Rubber foot or rubber suction pads at front
- ▶ Mains cable length 1.8 m

Mobilboy E EQUIPMENT:

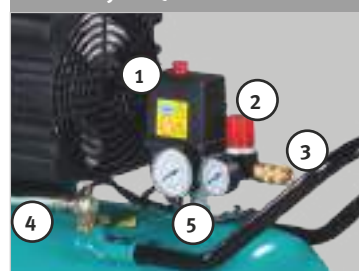

- ① Automatic pressure switch
- ② Pressure regulator for continuous adjustment of the working pressure
- ③ One single-handed, quick-action coupling
- ④ Aluminium compressed air line
- ⑤ One pressure gauge each for displaying the tank and working pressure



Mobilboy 311/50 E
▶ With 50 l compressed air tank



Mobilboy 301/24 E
▶ With 24-litre compressed air tank



Mobilboy 361/50 E
▶ With premium twin-cylinder V motor and single-stage compression
▶ With 50 l compressed air tank

Model	① Mobilboy 301/24 E	② Mobilboy 311/50 E	③ Mobilboy 361/50 E
Art. no.	2003326	2003331	2003650
Technical specifications			
Compressor system*	HOS	HOS	HOS
Highest flow rate	260 l/min	284 l/min	356 l/min
Fill capacity approx.	170 l/min	190 l/min	215 l/min
Maximum pressure	10 bar	10 bar	10 bar
Tank capacity	24 l	50 l	50 l
Cylinders/stages	1/1	1/1	2/1
Speed	2 850 rpm	2 850 rpm	2 850 rpm
Motor output	1.8 kW / 230 V	2.2 kW / 230 V	2.2 kW / 230 V
Weight	26 kg	36.5 kg	38 kg
Dimensions (L x W x H) in mm	580 x 310 x 615	870 x 350 x 700	870 x 350 x 700
Sound power level L _{WA} **	97 dB(A)	97 dB(A)	97 dB(A)

*For a description of the compressor systems refer to page 18 **Sound power level according to DIN EN ISO 3744 (RL 2000/14/EC)



Mobilboy 361/50 E

Overview of differences between E models and standard models

Electric models	Standard	
✓		Pressure regulator
	✓	Quality filter pressure regulator
		Automatic pressure switch
	✓	Automatic CONDOR pressure switch
✓	✓	Pressure gauge for displaying the tank and working pressure
✓		Single-handed quick-release coupling
	✓	Premium single-handed, quick-action coupling
✓		Aluminium compressed air lines
	✓	Copper compressed air lines

Mobilboy E EQUIPMENT:

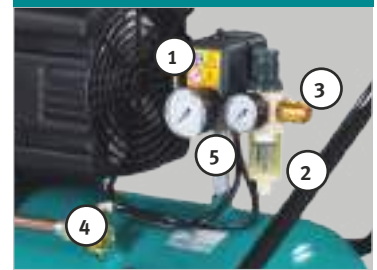

- ① High quality CONDOR quality pressure switch
- ② High quality filter pressure regulator
- ③ High quality single-handed, quick-action coupling
- ④ Copper compressed air line
- ⑤ One pressure gauge each for displaying the tank and working pressure

MADE IN ITALY



MOBILBOY 301/24 F

► Powder-coated compressed air tank

MADE IN ITALY



MOBILBOY 311/50 F

► Powder-coated compressed air tank

Model	④ MOBILBOY 301/24 F	⑤ MOBILBOY 311/50 F
Art. no.	2003325	2003330

Technical specifications*

	HOS	HOS
Compressor system*		
Highest flow rate	260 l/min	284 l/min
Fill capacity approx.	170 l/min	190 l/min
Maximum pressure	10 bar	10 bar
Tank capacity	24 l	50 l
Cylinders/stages	1/1	1/1
Speed	2 850 rpm	2 850 rpm
Motor output	1.8 kW / 230 V	2.2 kW / 230 V
Weight	26 kg	36.5 kg
Dimensions (L x W x H) in mm	580 x 310 x 615	870 x 350 x 700
Sound power level L _{WA} **	97 dB(A)	97 dB(A)

*For a description of the compressor systems refer to page 18 **Sound power level according to DIN EN ISO 3744 (RL 2000/14/EC)



MOBILBOY 301/24 F

MOBILBOY 311/50 F



COMPACT-AIR Series - The handy universal compressors for occasional on-site applications

- ▶ Universally deployable in occasional building applications and DIY
- ▶ Quality electric motors with high torque and motor starting current limiter to avoid start-up problems
- ▶ Electric motor equipped with soft-start and motor protection switch
- ▶ Fully automatic On/Off operation
- ▶ Equipped with all safety devices
- ▶ Good protection of all parts exposed to risk during transportation
- ▶ Complete maintenance block on inside
- ▶ Powder coated compressed air tanks
- ▶ Rubberised carrier handle prevents slipping during transportation
- ▶ Additional carrying handle allows convenient two-handed carrying of the compressor

COMPACT-AIR E models features:

- ▶ Pressure regulator for continuously variable setting of the desired working pressure
- ▶ Automatic pressure switch
- ▶ One pressure gauge each for displaying the tank and working pressure
- ▶ Single-handed quick-release coupling
- ▶ Aluminium compressed air lines
- ▶ Highly attractive pricing



COMPACT-AIR 221/10 E

- ▶ Including standard pressure regulator and quick coupling



COMPACT-AIR 265/10 E

- ▶ Including standard pressure regulator and quick coupling

COMPACT-AIR E Models



- ① Pressure regulator for continuously variable setting of the desired working pressure
- ② One pressure gauge each for displaying the tank and working pressure
- ③ One single-handed, quick-action coupling
- ④ Automatic pressure switch



Model	COMPACT-AIR 221/10 E	COMPACT-AIR 265/10 E
Art. no.	2005220	2005261
Technical data	HOS	HOS
Compressor system*		
Highest flow rate	185 l/min	250 l/min
Fill capacity approx.	120 l/min	155 l/min
Maximum pressure	8 bar	10 bar
Tank capacity	10 l	10 l
Cylinders/stages	1/1	1/1
Speed	2 850 rpm	2 850 rpm
Motor output	1.5 kW/ 230 V	1.5 kW/ 230 V
Weight	18 kg	22 kg
Dimensions (L x W x H) in mm	410 x 340 x 650	395 x 320 x 630
Sound power level L _{WA} **	94 dB(A)	96 dB(A)

*For a description of the compressor systems refer to page 18 **Sound power level according to DIN EN ISO 3744 (RL 2000/14/EC)

Mobile compressors COMPACT-AIR

COMPACT-AIR Series - the handy, universal compact-design compressor for on-site building and trade applications and DIY

Control panel

- ▶ The ergonomically situated control panel is clearly structured and self-explanatory.
- ▶ One pressure gauge each for displaying the tank and working pressure
- ▶ Includes a pressure regulator for continuous adjustability of the desired working pressure
- ▶ With two take-off points for compressed air
- ▶ Equipped with **premium quick-action couplings as a factory standard***



Protection function

- ▶ Compressor in protected hand cart construction
- ▶ The tubular frame provides optimal protection against damage to fittings.

Copper compressed air line

Maintenance block

- ▶ Equipped as a factory standard with a premium **CONDOR pressure switch***
- ▶ The on/off switch is protected and easily accessible
- ▶ Equipped with a quality filter for dirt, oil and condensate separation*

Fig. COMPACT-AIR 321/20

Handle

- ▶ Rubberised carrying handle as factory standard, prevents slipping during transportation

Motor

- ▶ Quality electric motors with powerful torque
- ▶ Motor starting current limiter to avoid start-up problems
- ▶ Electric motor equipped with soft-start and motor protection switch

Wheels

- ▶ The large stable wheels and the broad wheelbase provide for safe and comfortable transportation even on uneven surfaces

High-performance HOS unit

- ▶ The precision-machined piston has a high-alloyed piston ring, an oil scraper ring and oil spreader ring which provide a seal to the cylinder wall
- ▶ The crankcase is filled with oil which is sprayed against the cylinder wall with each piston stroke
- ▶ The oil scraper ring cleans the oil-wetted cylinder wall in downward direction



Fig. COMPACT-AIR 321/20

Compact design for convenient transportation. Perfectly suited for on-site applications thanks to all-round protection.

- ▶ Quality electric motors with high torque and motor starting current limiter to avoid start-up problems
- ▶ Electric motor equipped with soft-start and motor protection switch
- ▶ Fully automatic On/Off operation
- ▶ Good protection of all parts exposed to risk during transportation
- ▶ Rubberised carrier handle prevents slipping
- ▶ Equipped with all safety devices
- ▶ Compact design for convenient transportation.
- ▶ Perfectly suited for on-site applications thanks to all-round protection

Overview of differences between E models and standard models

Electric models	Standard	
✓		Automatic pressure switch
	✓	Automatic CONDOR pressure switch
✓	✓	Pressure gauge for displaying the tank and working pressure
	✓	Water separator
✓		Two single-handed quick-action couplings
	✓	Two premium, single-handed quick-action couplings
✓		Aluminium compressed air lines
	✓	Copper compressed air lines



COMPACT-AIR 311/20 E

- ▶ For occasional on-site applications



COMPACT-AIR 361/20 E

- ▶ With twin-cylinder V motor and single-stage compression
- ▶ For occasional on-site applications



COMPACT-AIR 321/20

- ▶ The low speed of 1 420 rpm reduces vibration and guarantees a longer service life of the twin-cylinder V motor.
- ▶ For on-site applications in building and trades
- ▶ Powder-coated compressed air tank

Model	COMPACT-AIR 311/20 E	COMPACT-AIR 361/20 E	COMPACT-AIR 321/20
Art. no.	2005291	2005361	2005300
Technical specifications			
Compressor system*	HOS	HOS	HOS
Intake capacity	284 l/min	356 l/min	310 l/min
Fill capacity approx.	190 l/min	215 l/min	240 l/min
Maximum pressure	10 bar	10 bar	10 bar
Tank capacity	20 l	20 l	20 l
Cylinders/stages	1 / 1	2 / 1	2 / 1
Speed	2 850 rpm	2 850 rpm	1 420 rpm
Motor output	2.2 kW / 230 V	2.2 kW / 230 V	2.2 kW / 230 V
Weight	33.5 kg	37 kg	39.5 kg
Dimensions (L x W x H) in mm	470 x 490 x 720	470 x 490 x 720	470 x 490 x 720
Sound power level **	97 dB(A)	97 dB(A)	96 dB(A)

*For a description of the compressor systems refer to page 18 ** Sound power level according to DIN EN ISO 3744 (RL 2000/14/EC)

Mobile compressors PRO

Pressure regulator

- ▶ The working pressure is continuously variable via the standard pressure regulator

Operation

- ▶ Equipped as a factory standard with a premium **CONDOR pressure switch**
- ▶ The on/off switch is protected and easily accessible
- ▶ One pressure gauge each for displaying the tank and working pressure

Chassis

- ▶ The large stable wheels and the broad wheelbase provide for safe and comfortable transportation even on uneven surfaces such as staircases

Compressed air take-off

- ▶ One take-off point for compressed air
- ▶ Equipped with premium quick-action couplings as a factory standard



Fig. COMPACT-AIR BX 330 OF PRO

Base

- ▶ There are no fittings or switches in the base area that could suffer damage when tilting or transporting the compressor

Tray

- ▶ Practical for daily use as a tray for tools, plans, etc. and to provide protection against damage from above



Oil-free!

HDS - High performance continuous lubricating system

- ▶ Developed for demanding, continuous use wherever oil-free and clean compressed air is required

Operation

- ▶ Equipped as a factory standard with a premium **CONDOR pressure switch**
- ▶ The control panel is clearly structured and self-explanatory.
- ▶ One pressure gauge each for displaying the tank and working pressure
- ▶ Two compressed air take-off points
- ▶ Equipped with **premium quick-action couplings as a factory standard**
- ▶ On/off switch is protected from the top and easily accessible



Fig. AIRCAR BX 330 OF PRO

BX series - the high-performance, low maintenance on-site air compressor with patented, oil-free compressor system and professional features for builders and other trades



- ▶ Ideal for builders and trades for on-site use - universally deployable for installation work and in workshops
- ▶ **With an oil-free compressor** allowing best quality of work and a long service life of compressed air tools
- ▶ The unique form factor allows the use of compressed air tools with high air supply requirements despite the low start-up current
- ▶ **Designed for the continuous operation**; the compressor can run for extended periods of time without overheating
- ▶ Smooth action and low speed guarantee really low operating noise and a long compressor service life
- ▶ **Low maintenance**
- ▶ Premium electric motor with high torque and motor starting current limiter. This guarantees easy start-up
- ▶ Electric motor equipped with soft-start and motor protection switch
- ▶ Fully automatic On/Off operation
- ▶ Equipped with all safety devices
- ▶ **With premium quick-action couplings and a premium CONDOR pressure switch**

- ▶ **Specially designed for work areas where it is necessary to work with clean air or at low temperatures, for example, in plasma cutting, and in the food and delicatessen industries**
- ▶ The large stable wheels and the broad wheelbase provide for safe and comfortable transportation
- ▶ Lightweight for easy transportation

AIRPROFI BX 660/100 OF PRO:

- ▶ With double piston and horizontal compression
- ▶ With phase changer
- ▶ With premium quick-action, single-handed couplings
- ▶ Third compressed air take-off point via direct outlet with ball valve on the tank
- ▶ Flexible armoured hose
- ▶ Longer service life and greater reliability
- ▶ Low maintenance
- ▶ Interior and exterior of compressed air tank hot-dip galvanised

Patented technology!

- ▶ The pistons move axially in special ceramic coated aluminium cylinder, like in a flat engine.
- ▶ This drastically reduces the wear on the seals.
- ▶ This removes the need for the frequent and expensive maintenance that has to be performed on legacy dry compressors.
- ▶ Designed for continuous operation

- 1) Seal
- 2) Piston
- 3) Piston ring
- 4) Valve plate
- 5) Filter

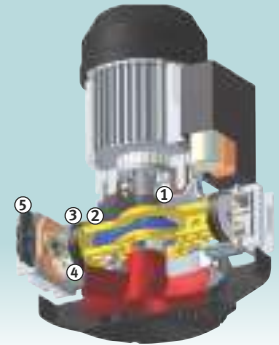

Oil-free!



Very quiet



COMPACT-AIR BX 240 SILENT COMPACT-AIR BX 330 OF PRO

- ▶ Two identical models
- ▶ With pressure regulator, premium CONDOR pressure switch, - one pressure gauge each for the tank pressure and preset pressure
- ▶ With one premium single-handed quick coupling as standard



Oil-free!



AIRCAR BX 330 OF PRO

- ▶ Equipments as per Compact-Air BX 330 OF PRO
- ▶ With two premium single-handed quick couplings as standard
- ▶ Close frame design, thus optimal protection for motor and maintenance block



Oil-free!



AIRPROFI BX 660/100 OF PRO

- ▶ High-performance permanent lubrication system: developed for demanding, continuous use wherever oil-free and clean compressed air is required.
- ▶ Ergonomic handle extension
- ▶ Steering chassis with parking brake
- ▶ PU foam wheels

Model	COMPACT-AIR BX 240 SILENT	COMPACT-AIR BX 330 OF PRO	AIRCAR BX 330 OF PRO	AIRPROFI BX 660/100 OF PRO
Art. no.	2005310	2005301	2005400	2015663

Technical data	COMPACT-AIR BX 240 SILENT	COMPACT-AIR BX 330 OF PRO	AIRCAR BX 330 OF PRO	AIRPROFI BX 660/100 OF PRO
Compressor system*	HDS	HDS	HDS	HDS
Highest flow rate	240 l/min	330 l/min	330 l/min	660 l/min
Fill capacity approx.	150 l/min	200 l/min	200 l/min	400 l/min
Maximum pressure	10 bar	10 bar	10 bar	10 bar
Tank capacity	24 l	24 l	2 x 10 l	100 l
Cylinders/stages	2/1	2/1	2/1	4/1
Speed	1 400 rpm	1 400 rpm	1 400 rpm	1 400 rpm
Motor output	1.8 kW / 230 V	2.2 kW / 230 V	2.2 kW / 230 V	3.4 kW / 400 V
Weight	34 kg	36 kg	43 kg	87 kg
Dimensions (L x W x H) in mm	500 x 560 x 810	500 x 560 x 810	670 x 545 x 570	1280 x 470 x 850 mm
Sound pressure level L _{PA} **	65 dB(A)	80 dB(A)	78 dB(A)	84 dB(A)
Sound power level L _{WA} ***	78 dB(A)	96 dB(A)	96 dB(A)	-

* For a description of the compressor systems refer to page 18 ** Sound pressure level at a distance of 1 m as per DIN 45635 T 13 *** Sound power level as per DIN EN ISO 3744 (RL 2000/14/EC)

Compact-AIR

COMPACT-AIR PRO - powerful, universally applicable compressors with a compact design and all-round protection

Operation

- ▶ Equipped as a factory standard with a premium **CONDOR pressure switch**
- ▶ On/off switch is protected from the top and easily accessible
- ▶ The ergonomically-mounted control panel is clearly structured and self-explanatory
- ▶ One pressure gauge each for displaying the tank and working pressure
- ▶ Three compressed air outlets for filtered compressed air, filtered and lubricated compressed air and a direct compressed air outlet on the compressed air tank
- ▶ Equipped with **premium quick-action couplings as a factory standard**



Cable hook

- ▶ Including interior protected cable hook

Hose hook

- ▶ Supplied with a protected hose hook on the inside as standard
- ▶ The hose is not included in the scope of delivery



Fig. COMPACT-AIR 321/24 PRO

Tray

- ▶ The tool tray positioned above the compressor protects it additionally during transportation
- ▶ And the tray is the perfect place to deposit your tools
- ▶ **Suitable for standard system containers** by all major power tool manufacturers, such as Makita, Festool, Mafell, etc.

Filter pressure regulator

- ▶ The working pressure is infinitely variable via the standard filter pressure regulator with simultaneous separation of dirt and condensate

Base

- ▶ There are no fittings or switches in the base area that could suffer damage when tilting or transporting the compressor

High-performance HOS unit

- ▶ The precision-machined piston has a high-alloyed piston ring, an oil scraper ring and oil spreader ring which provide a seal to the cylinder wall
- ▶ The crankcase is filled with oil which is sprayed against the cylinder wall with each piston stroke
- ▶ The oil scraper ring cleans the oil-wetted cylinder wall in downward direction



Chassis

- ▶ The large stable wheels and **puncture proof tyres made of PU foam** in combination with the wide wheelbase ensure safe and convenient transportation even on uneven surfaces such as staircases

Handle

- ▶ Rubberised carrying handle as factory standard, prevents slipping during transportation

Protection function

- ▶ Compressor with all-round protected design
- ▶ The tubular frame and the top-mounted tray provide perfect protection against damage to fittings.

High quality compressed air tank

- ▶ Powder coated compressed air tanks



Fig. COMPACT-AIR 321/24 PRO

Compact-AIR 425/20 E – handy, mobile universal compressor for use on site

- ▶ Universally deployable in on-site, trade and building applications
- ▶ Switch and fittings perfectly protected by tubular frame
- ▶ Compressed air outlet via two single-handed quick-action couplings
- ▶ Control panel clearly structured and self-explanatory
- ▶ Pressure regulator with pressure gauge for infinitely variable setting of the desired working pressure
- ▶ Automatic CONDOR pressure switch
- ▶ Electric motor equipped with soft-start and motor protection switch
- ▶ Good protection of all parts exposed to risk during transportation
- ▶ Rubberised carrying handles prevent slipping during transportation
- ▶ Additional carrying handle allows convenient carrying of the compressor
- ▶ Includes mains cable length 3 m
- ▶ Ball valve for draining the tank
- ▶ Vibration-damping rubber suction feet
- ▶ Sturdy wheels with full-rubber tyres
- ▶ Practical hose reel holder integrated
- ▶ Equipped with all safety devices
- ▶ Fully automatic On/Off operation
- ▶ Powder coated tank

Model	COMPACT-AIR 425/20 E
Art. no.	2005470

Technical data	
Compressor system*	HOS
Highest flow rate	422 l/min
Fill capacity approx.	225 l/min
Maximum pressure	10 bar
Tank capacity	20 l
Cylinders/stages	2/1
Speed	2 850 rpm
Rating	2.4 kW
Electrical connection	230 V / 50 Hz
Weight	58 kg
Dimensions (L x W x H)	800 x 540 x 530 / 1 170 mm
Sound pressure level L _{PA} **	75 dB(A)
Sound power level L _{WA} ***	80 dB(A)



COMPACT-AIR 425/20 E
With folding transport handle



COMPACT-AIR 425/20 E
Ideal for compressed air hose reel DST 8/30 (not included in scope of supply)

COMPACT-AIR PRO - Compact design for convenient transportation. Perfectly suited for daily on-site applications thanks to all-round protection.

- ▶ Universally suitable for use in the assembly and trade sectors
- ▶ COMPACT-AIR 341/24 PRO with single-cylinder compressor
- ▶ Low speed guarantees smooth action and a long compressor service life
- ▶ The PU foam tyres and the broad wheelbase ensure safe and comfortable transportation
- ▶ Flexible armoured hose line with heat protection avoids vibration fractures
- ▶ Premium electric motor with high torque
- ▶ Electric motor equipped with soft-start and motor protection switch
- ▶ Fully automatic On/Off operation
- ▶ Optimum protection of all parts exposed to risk during transportation
- ▶ Equipped with all safety devices
- ▶ With **premium quick-action couplings and a premium CONDOR pressure switch**
- ▶ Powder-coated compressed air tank



COMPACT-AIR 321/24 PRO
▶ With smooth action twin-cylinder compressor

Model	COMPACT-AIR 321/24 PRO
Art. no.	2005352

Technical data	
Compressor system*	HOS
Highest flow rate	310 l/min
Fill capacity approx.	240 l/min
Maximum pressure	10 bar
Tank capacity	24 l
Cylinders/stages	2/1
Speed	1 420 rpm
Motor output	2.2 kW / 230 V
Weight	51 kg
Dimensions (L x W x H) in mm	600 x 640 x 980
Sound pressure level L _{PA} **	75 dB(A)
Sound power level L _{WA} ***	91 dB(A)

* For a description of the compressor systems, see page 18

** Sound pressure level at 1 m distance as per DIN 45635 T 13 *** Sound power level as per DIN EN ISO 3744 (RL 2000/14/EC)

COMPACT-AIR PRO – Your benefits thanks to the unique design

- Tool tray**
- ▶ The tool tray positioned above the compressor protects it additionally during transportation.
 - ▶ And the tray is the perfect place to deposit your tools.
 - ▶ Suitable for standard system containers by all major power tool manufacturers, such as Makita, Festool, Mafell, etc.



Perfect frame ergonomics

- ▶ Can be transported up or down a staircase by one person
- ▶ Easy to tilt
- ▶ Can be easily moved without risk of back injuries
- ▶ Stable base



Mobile compressors PRO

AIRCAR PRO - the powerful, mobile compressed air centre with practical details in a compact format for professional use

Operation

- ▶ Equipped as a factory standard with a premium CONDOR pressure switch
- ▶ On/off switch is protected from the top and easily accessible
- ▶ The ergonomically-mounted control panel is clearly structured and self-explanatory
- ▶ One pressure gauge each for displaying the tank and working pressure
- ▶ One compressed air outlet each for filtered compressed air, filtered and oiled compressed air and a compressed air direct outlet from the tank
- ▶ Equipped with **convenient quick-action safety couplings as a factory standard**



Base

- ▶ There are no fittings or switches in the base area that could suffer damage when tilting or transporting the compressor

Protection function

- ▶ The frame provides space for storing tools as well as all-round protection for the various sensitive components
- ▶ The tubular frame and the top-mounted tray provide perfect protection against damage to fittings.

Filter pressure regulator

- ▶ The working pressure is infinitely variable via the standard filter pressure regulator with simultaneous separation of dirt and condensate

Oil mist lubricator

- ▶ The factory-standard oil mist lubricator ensures a sufficient supply of lubricant to tools



AIRCAR 553/22 PRO

High-performance HOS unit

- ▶ The precision-machined piston has a high-alloyed piston ring, an oil scraper ring and oil spreader ring which provide a seal to the cylinder wall
- ▶ The crankcase is filled with oil which is sprayed against the cylinder wall with each piston stroke
- ▶ The oil scraper ring cleans the oil-wetted cylinder wall in downward direction

Handles

- ▶ Equipped with fold-out carrying handles for lifting during transportation

Hose hook

- ▶ Supplied with a protected hose hook on the inside
- ▶ The hose is not included in the scope of delivery

High quality compressed air tank

- ▶ Powder coated compressed air tanks



AIRCAR 553/22 PRO



Chassis

- ▶ The large stable wheels and **puncture proof tyres made of PU foam** in combination with the wide wheelbase ensure safe and convenient transportation even on uneven surfaces such as staircases

Compact design for convenient transportation. Perfectly suited for daily on-site applications thanks to all-round protection.

- ▶ For building and trade applications, e.g., in the workshop, or for interior construction work and building shell construction
- ▶ The frame provides space for storing tools as well as all-round protection for the various sensitive components
- ▶ The twin-cylinder high-performance V motor in grey cast iron and the low speed guarantee smooth action and a long compressor service life.
- ▶ Flexible armoured hose line with heat protection avoids vibration fractures
- ▶ One pressure gauge each for displaying the tank and working pressure
- ▶ Three compressed air take-off points with quick-action safety couplings for filtered compressed air, filtered and oiled compressed air, and a direct compressed air outlet from the compressed air tank
- ▶ High-quality CONDOR pressure switch
- ▶ Puncture-resistant PU foam wheels in conjunction with a broad wheelbase ensure comfortable and safe transport
- ▶ Powder-coated compressed air tank
- ▶ Premium electric motor with high torque and motor starting current limiter to avoid start-up problems
- ▶ Electric motor equipped with soft-start and motor protection switch
- ▶ Fully automatic On/Off operation
- ▶ Equipped with all safety devices



AIRCAR 321/22 PRO



AIRCAR 553/22 PRO

Model	AIRCAR 321/22 PRO	AIRCAR 553/22 PRO
Art. no.	2005531	2005553
Technical specifications	HOS	HOS
Compressor system*		
Highest flow rate	310 l/min	550 l/min
Fill capacity approx.	240 l/min	410 l/min
Maximum pressure	10 bar	10 bar
Tank capacity	2 x 11 l	2 x 11 l
Cylinders/stages	2/1	2/1
Speed	1 420 rpm	1 420 rpm
Motor output	2.2 kW / 230 V	3 kW / 400 V
Weight	53 kg	77 kg
Dimensions (L x W x H) in mm	780 x 685 x 670	780 x 685 x 670
Sound pressure level L _{PA} **	75 dB(A)	81 dB(A)
Sound power level L _{WA} ***	91 dB(A)	94 dB(A)

* For a description of the compressor systems, see page 18

** Sound pressure level at 1 m distance as per DIN 45635 T 13 *** Sound power level as per DIN EN ISO 3744 (RL 2000/14/EC)

Your benefits

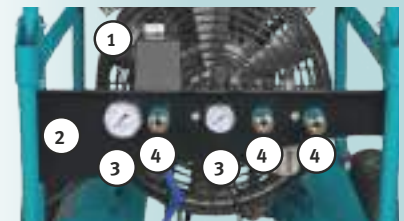

Features

- 1 On/off switch is protected from the top and easily accessible
- 2 The ergonomically-mounted control panel is clearly structured and self-explanatory
- 3 One pressure gauge each for displaying the tank and working pressure
- 4 Three compressed air outlets for filtered compressed air, filtered and lubricated compressed air and a direct compressed air outlet on the compressed air tank
· With premium quick-action couplings and premium CONDOR pressure switch



- ▶ Features a powerful twin-cylinder high-performance V motor in grey cast iron
- ▶ With low-wear direct drive

Mobile compressors PRO

AIRBAU/AIRCAR-BAU - Compressor with internal combustion engine for up to 14 bar operating pressure for work environments without a power supply

Transport lugs

- ▶ With two transport lugs on the frame for lifting, e.g., with a crane

Tray

- ▶ Practical for daily use as a tray for tools, plans, etc. and to provide protection against damage from above

High-performance HOS unit

- ▶ The precision-machined piston has a high-alloyed piston ring, an oil scraper ring and oil spreader ring which provide a seal to the cylinder wall
- ▶ The crankcase is filled with oil which is sprayed against the cylinder wall with each piston stroke
- ▶ The oil scraper ring cleans the oil-wetted cylinder wall in downward direction

Transport handle

- ▶ The handle for two-handed gripping ensures safe transport to the deployment site

- ▶ The working pressure can be infinitely set via the filter pressure regulator to allow for reduced pressure, filtered compressed air take-off
- ▶ Two pressure gauges indicate the tank and working pressure
- ▶ Equipped with a **quality quick-action coupling and CONDOR premium pressure switch as a factory standard**

Anti-vibration elements

- ▶ Equipped with two large and wide anti-vibration elements for stability

All-round protection

- ▶ The frame acts as a compressed air tank, tool tray holder, and at the same time provides all-round protection for any sensitive components
- ▶ Optimum protection and portable high performance



Freewheel valve

- ▶ Features freewheel valve as factory standard
- ▶ This removes the need for continually switching on and off
- ▶ The compressor continues to run in no-load state after reaching the preset pressure



PU foam wheels

- ▶ The large stable wheels and **puncture proof tyres made of PU foam** in combination with the wide wheelbase ensure safe and convenient transportation even on uneven surfaces



AIRCAR-BAU 500/20 B PRO

AIRBAU/AIRCAR-BAU - for use in gardening and landscape gardening, for mobile tyre and breakdown recovery services and in agriculture and forestry

- ▶ Single cylinder/4-stroke engine by Honda for power-supply independent operation.
- ▶ Independent of a power supply and thus perfectly suited for gardening and landscape gardening, for mobile tyre and breakdown recovery services and in agriculture and forestry
- ▶ With idle speed and speed control to adjust to load states
- ▶ The high-performance grey cast iron power unit and the low speed guarantee smooth action and a long service life
- ▶ The large impeller and a cooling air duct ensure optimum cooling of the compressor
- ▶ Stable metal belt guard grille
- ▶ A re-cooler with large-surface cooling fins ensures a low compressed air tank inlet temperature, thus reducing the moisture content of the compressed air
- ▶ Equipped with all safety devices



AIRBAU 652/100 B PRO

- ▶ Features a 100-litre compressed air tank
- ▶ Perfectly suited for use in breakdown recovery vehicles due to its very narrow form factor



AIRCAR-BAU 500/20 B PRO

- ▶ With transport lugs on the frame for lifting
- ▶ The form factor, the puncture-proof PU foam tyres and the transport handles ensure easy transportation to the deployment site

Model	AIRBAU 652/100 B PRO	Aircar-BAU 500/20 B PRO
Art. no.	2006530	2005500

Technical specifications	HOS	HOS
Compressor system*	HOS	HOS
Highest flow rate	642 l/min	365 l/min
Fill capacity approx.	480 l/min	285 l/min
Maximum pressure	14 bar	10 bar
Tank capacity	100 l	20 l
Cylinders/stages	2/2	2/1
Speed	950 rpm	1 375 rpm
Motor output	6.6 kW	4 kW
Drive	Single-cylinder/4-stroke engine	Single-cylinder/4-stroke engine
Weight	121 kg	72 kg
Dimensions (L x W x H) in mm	1 050 x 500 x 1 060	750 x 700 x 950
Sound power level **	99 dB(A)	97 dB(A)

* For a description of the compressor systems, see page 18

** Sound power level as per DIN EN ISO 3744 (RL 2000/14/EC)

Freewheel valve for less wear

- ▶ The freewheel valve avoids continuous switching on and off
- ▶ After reaching the preset pressure, the valve opens and the compressor continues to run in depressurised state
- ▶ When the pressure drops, the valve shuts-off and the compressor builds up pressure again



Our tip!

Only compress to the level you really need; after all, compressing just one “bar” more will cost 10% more energy.

Piston compressors are more economical than screw-type compressors in case of low and fluctuating compressed air requirements. Piston compressors support start/stop operation and do not have an idle mode.



AIRSTAR E



AIRSTAR



AIRPROFI

AIRSTAR E series - compressors for home and DIY with a proven belt-driven and twin-cylinder, high-performance grey cast iron motor.

- ▶ Twin-cylinder high-performance grey cast iron motor for a long service life
- ▶ Large impeller and a cooling air baffle on the cylinder ensure optimum cooling of the compressor
- ▶ Premium electric motor with high torque
- ▶ Electric motor equipped with soft-start and motor protection switch
- ▶ A re-cooler with large-surface cooling fins ensures a low compressed air tank inlet temperature, thus reducing the moisture content of the compressed air.
- ▶ Stable metal belt guard grille
- ▶ A start-up capacitor and start-up relief valve ensure a soft start for 230 volt models
- ▶ 400 volt models are equipped with a phase inverter as a factory standard for easy manual changing of the direction of rotation
- ▶ The compressed air tank is equipped with a safety valve, tank pressure gauge and a condensate drain valve
- ▶ Equipped with all safety devices
- ▶ Complete and ready to connect

E model features

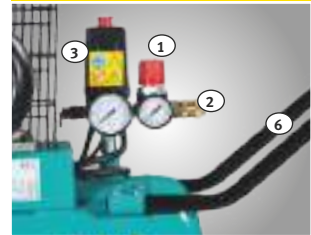

- ① **Pressure regulator** for continuously variable setting of the desired working pressure
 - One pressure gauge each for displaying the tank and working pressure
- ② **Easy single-handed, quick-action coupling**
- ③ **Automatic pressure switch**
- ④ **Plastic wheels at rear**
- ⑤ **Rubber suction feet at front**
- ⑥ **Simple handle design**
Similar to detailed illustration



AIRSTAR 321/50 E

















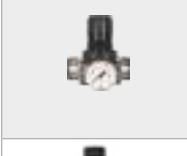



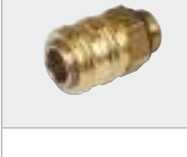

AIRSTAR 401/50 E
AIRSTAR 403/50 E

Model	AIRSTAR 321/50 E	AIRSTAR 401/50 E	AIRSTAR 403/50 E
Art. no.	2008312	2009413	2009433
Technical specifications			
Compressor system*	HOS	HOS	HOS
Highest flow rate	235 l/min	365 l/min	365 l/min
Fill capacity approx.	180 l/min	270 l/min	270 l/min
Maximum pressure	10 bar	10 bar	10 bar
Tank capacity	50 l	50 l	50 l
Cylinders/stages	2/1	2/1	2/1
Speed	1 400 rpm	1 375 rpm	1 375 rpm
Motor output	1.5 kW / 230 V	2.2 kW / 230 V	2.2 kW / 400 V
Weight	48.5 kg	57.5 kg	57.5 kg
Dimensions (L x W x H) in mm	870 x 400 x 700	870 x 400 x 700	870 x 400 x 700
Sound power level**	92 dB(A)	94 dB(A)	94 dB(A)

* For a description of the compressor systems refer to page 18 ** Sound power level according to DIN EN ISO 3744 (RL 2000/14/EC)

Features AIRSTAR E / AIRSTAR / AIRPROFI at a glance

	Arguments that speak for themselves.	AIRSTAR E Series	AIRSTAR Series	AIRPROFI Series
	<ul style="list-style-type: none"> Automatic pressure switch 	✓		
	<ul style="list-style-type: none"> High quality MDR CONDOR pressure switch Fully automatic On/Off operation 		✓	✓
	<ul style="list-style-type: none"> Power connection cable with plug For easy manual inversion of the sense of rotation 	✓	✓	✓
	<ul style="list-style-type: none"> Simple transport handle 	✓		
	<ul style="list-style-type: none"> Ergonomic transport handle with rubber grip 		✓	
	<ul style="list-style-type: none"> Extended ergonomic transport handle with rubber grip 			✓
	<ul style="list-style-type: none"> Pressure regulator 	✓		
	<ul style="list-style-type: none"> Filter pressure regulator 		✓	
	<ul style="list-style-type: none"> Filter pressure regulator with oil mist lubricator 			✓
	<ul style="list-style-type: none"> Single-handed quick-release coupling 	✓		
	<ul style="list-style-type: none"> Premium, single-handed quick-action couplings 		✓	
	<ul style="list-style-type: none"> Single-handed quick-action safety couplings as per DIN EN 983 			✓

	Arguments that speak for themselves.	AIRSTAR E Series	AIRSTAR Series	AIRPROFI Series
	<ul style="list-style-type: none"> Two compressed air take-off points for filtered compressed air 			✓
	<ul style="list-style-type: none"> Third compressed air take-off point via direct outlet with ball valve on the tank 			✓
	<ul style="list-style-type: none"> Toothed drive belt Large impeller and one cooling air baffle 		✓	✓
	<ul style="list-style-type: none"> Twin-cylinder high-performance motor in grey cast iron and low speed with HOS compressor 	✓	✓	✓
	<ul style="list-style-type: none"> Flexible armoured hose with heat protection 		✓	✓
	<ul style="list-style-type: none"> With two plastic wheels at the back and two damping elements at the front 	✓		
	<ul style="list-style-type: none"> Rugged steering chassis with parking brake PU foam tyres 		✓	✓
	<ul style="list-style-type: none"> Features a practical transport handle on the compressed air tank 		✓	✓
	<ul style="list-style-type: none"> Ball valve 3/8 inch female for draining condensate 			✓

AIRSTAR Series

Robust quality in trade and demanding DIY applications.



- ▶ **Maintenance block** with fixed screw connectors and filter pressure regulator
- ▶ Two large pressure gauges for displaying the tank and working pressure



- ▶ **MDR CONDOR pressure switch** - fully-automated On/Off operation

- ▶ Transport handle with rubber grip

- ▶ Powder coating



- ▶ Steering chassis with parking brake



- ▶ With premium, single-handed quick-action couplings



- ▶ Toothed drive belt



- ▶ Corrosion-free valve plates

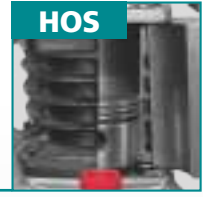

HOS

- ▶ **2-cylinder high-performance grey cast unit, slow running** Re-cooler with large cooling fins

- ▶ **Large impeller and one cooling air baffle** on the cylinder Stable metal belt guard grille



- ▶ Transport handle on the compressed air tank

- ▶ Flexible armoured hose with heat protection
- ▶ Start-up relief valve



- ▶ Puncture-proof PU foam wheels

- ▶ **Quality electric motor** with high torque, equipped with motor protection switch



- ▶ 400 volts models equipped with phase inverter for easy manual inversion of the sense of rotation

Prepare to be fascinated!
For more information, check out our movie presentation.



Maximum equipment level, best quality and an attractive price!



► **Maintenance block** with fixed screw connectors and filter pressure regulator

► **Two compressed air take-off points**

► Two large pressure gauges for displaying the tank and working pressure



► **MDR CONDOR pressure switch** - fully-automated On/Off operation

► Ergonomically extended handle with rubberised grip

► **Third compressed air take-off point** via direct outlet with ball valve on the tank

► Compressed air tank hot-dip galvanised inside and out as standard



► **Steering chassis** with parking brake



► **Equipped with single-handed quick-action safety couplings** as per DIN EN 983



► **Toothed drive belt**



► **Corrosion-free valve plates**

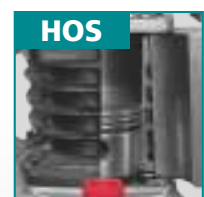

► **HOS**
Twin-cylinder high-performance motor in grey cast iron and low speed Re-cooler with large cooling fins

► **Large impeller and one cooling air baffle** on the cylinder Stable metal belt guard grille



► **Transport handle** on the compressed air tank

► **Flexible armoured hose** with heat protection
► **Start-up relief valve**



► **Puncture-proof PU foam wheels**



► **Ball valve** installed as standard 3/8 inch female

► **The quality electric motor** with high torque



► **400 volts models** equipped with phase inverter for easy manual inversion of the sense of rotation

Prepare to be fascinated!
For more information, check out our movie presentation.



AIRSTAR series - rugged compressors for building and other trades with a proven belt-driven and twin-cylinder, high-performance grey cast iron motor, and professional accessories.

- ▶ Twin-cylinder high-performance grey cast iron motor for a long service life
- ▶ Large impeller and a cooling air baffle on the cylinder ensure optimum cooling of the compressor
- ▶ Premium electric motor with high torque
- ▶ Electric motor equipped with soft-start and motor protection switch
- ▶ A re-cooler with large-surface cooling fins ensures a low compressed air tank inlet temperature, thus reducing the moisture content of the compressed air.
- ▶ Stable metal belt guard grille
- ▶ A start-up capacitor and start-up relief valve ensure a soft start for 230 volt models
- ▶ 400 volt models are equipped with a phase inverter as a factory standard for easy manual changing of the direction of rotation
- ▶ Pressure tank equipped with a safety valve, tank pressure gauge and a condensate drain valve
- ▶ Equipped with all safety devices
- ▶ Complete and ready to connect
- ▶ Filter pressure regulator with a pressure gauge for controlled condensate-, dirt- and oil-free compressed air; second pressure gauge for the compressed air tank pressure.
- ▶ Powder-coated compressed air tank
- ▶ With premium quick-action couplings and a premium **CONDOR** pressure switch
- ▶ With a flexible, heat protected **armoured hose** for a long service life, as vibration breaks are ruled out
- ▶ Including an ergonomic handle, rubberised grip and transport handle on the compressed air tank for convenient transportation
- ▶ With a stable **steering chassis and parking brake in combination with large puncture-proof wheels** for convenient transportation



AIRSTAR 401/50
AIRSTAR 403/50



AIRSTAR 503/50



AIRSTAR 503/100

Model	AIRSTAR 401/50	AIRSTAR 403/50	AIRSTAR 503/50	AIRSTAR 503/100
Art. no.	2009410	2009430	2009530	2009531
Technical specifications	HOS	HOS	HOS	HOS
Compressor system*				
Highest flow rate	365 l/min	390 l/min	510 l/min	510 l/min
Fill capacity approx.	266 l/min	285 l/min	400 l/min	400 l/min
Maximum pressure	10 bar	10 bar	10 bar	10 bar
Tank capacity	50 l	50 l	50 l	100 l
Cylinders/stages	2/1	2/1	2/1	2/1
Speed	1 360 rpm	1 470 rpm	1 310 rpm	1 310 rpm
Motor output	2.2 kW / 230 V	2.2 kW / 400 V	3 kW / 400 V	3 kW / 400 V
Weight	57.5 kg	57.5 kg	65 kg	75 kg
Dimensions (L x W x H) in mm	860 x 440 x 800	860 x 440 x 800	860 x 440 x 880	1 125 x 480 x 925
Sound power level**	96 dB(A)	96 dB(A)	94 dB(A)	94 dB(A)

* For a description of the compressor systems refer to page 18 ** Sound power level according to DIN EN ISO 3744 (RL 2000/14/EC)

AIRSTAR 703/853 - two-stage compression

- ▶ The twin-cylinder, high-performance motor with two-stage compression runs at low speed to achieve a very smooth, virtually vibration free action
- ▶ This ensures an even longer service life by reducing wear
- ▶ Equipped with an intermediate cooler in addition to the re-cooler



AIRSTAR 703/100



AIRSTAR 853/200

Model	AIRSTAR 703/100	AIRSTAR 853/100	AIRSTAR 853/200
Art. no.	2009731	2009831	2009832

Technical specifications	HOS	HOS	HOS
Compressor system*			
Highest flow rate	650 l/min	850 l/min	850 l/min
Fill capacity approx.	520 l/min	680 l/min	680 l/min
Maximum pressure	10 bar	10 bar	10 bar
Tank capacity	100 l	100 l	200 l
Cylinders/stages	2/2	2/2	2/2
Speed	950 rpm	1 240 rpm	1 240 rpm
Motor output	4 kW / 400 V	5.5 kW*** / 400 V	5.5 kW*** / 400 V
Weight	99 kg	112 kg	153 kg
Dimensions (L x W x H) in mm	1 125 x 480 x 1 015	1 125 x 480 x 1 015	1 190 x 680 x 1 150
Sound power level **	93 dB(A)	95 dB(A)	95 dB(A)

* For a description of the compressor systems refer to page 18 ** Sound power level according to DIN EN ISO 3744 (RL 2000/14/EC) *** For compressors with a motor output of 5.5 kW, please observe your local electricity utility's rules; the use of a star-delta switch may be required in some areas



Mobile AIRSTAR features

- The working pressure can be infinitely set via the pressure regulator to allow for reduced pressure compressed air take-off
- Two pressure gauges indicate the tank and working pressure
- With filter pressure regulator
- Equipped with **quality quick couplings** and a premium **CONDOR pressure switch as standard**



- A re-cooler with large-surface cooling fins ensures a low compressed air tank inlet temperature, thus reducing the moisture content of the compressed air.
- This is gentle on the connected compressed air tools.



- Puncture-proof tyres filled with PU foam and thus puncture proof (except AIRSTAR 853/200)
- Avoiding flat tyres without compromising convenience



- Rugged steering chassis with parking brake

AIRPROFI Series - single-stage and two-stage

AIRPROFI Series - Professional compressors with a twin-cylinder, high-performance grey cast iron motor and a maximum equipment level

- ▶ The high-performance grey cast iron motor and the low speed guarantee smooth action and a long compressor service life
- ▶ A re-cooler with large cooling fins ensures a low compressed air tank inlet temperature, thus reducing the moisture content of the compressed air
- ▶ The large fan wheel and a cooling air baffle on the cylinder provide for optimum cooling of the compressor
- ▶ Premium electric motor with high torque
- ▶ Electric motor equipped with soft-start and motor protection switch
- ▶ A start-up capacitor and start-up relief valve ensure a smooth start-up
- ▶ 400 volt models are equipped with a phase inverter as a factory standard for easy manual changing of the direction of rotation
- ▶ Flexible armoured hose with heat protection avoids vibration fractures.
- ▶ The toothed drive belt facilitates starting.
- ▶ Stable metal belt guard grille
- ▶ Fully automatic On/Off operation
- ▶ Extended handle with rubber grip
- ▶ Puncture-resistant PU foam wheels and a sturdy steering chassis with parking brake enable easy transport, as the compressor does not need to be lifted during transport.
- ▶ Interior and exterior of compressed air tank hot-dip galvanised
- ▶ **With premium quick-action couplings and a premium CONDOR pressure switch**
- ▶ Equipped with all safety devices
- ▶ Complete and ready to connect



AIRPROFI 401/50
AIRPROFI 403/50



AIRPROFI 503/50



AIRPROFI 503/100

Model	AIRPROFI 401/50	AIRPROFI 403/50	AIRPROFI 503/50	AIRPROFI 503/100
Art. no.	2018410	2018430	2018530	2018531
Technical specifications				
Compressor system*	HOS	HOS	HOS	HOS
Highest flow rate	365 l/min	390 l/min	510 l/min	510 l/min
Fill capacity approx.	266 l/min	285 l/min	400 l/min	400 l/min
Maximum pressure	10 bar	10 bar	10 bar	10 bar
Tank capacity	50 l	50 l	50 l	100 l
Cylinders/stages	2/1	2/1	2/1	2/1
Speed	1 360 rpm	1 470 rpm	1 310 rpm	1 310 rpm
Motor output	2.2 kW/ 230 V	2.2 kW/ 400 V	3 kW/ 400 V	3 kW/ 400 V
Weight	56 kg	56 kg	66 kg	76 kg
Dimensions (L x W x H) in mm	810 x 430 x 790	810 x 430 x 790	860 x 440 x 880	1 275 x 480 x 925
Sound pressure level L _{WA} ***	96 dB(A)	96 dB(A)	95 dB(A)	93 dB(A)

* For a description of the compressor systems refer to page 18 *** Sound power level as per DIN EN ISO 3744 (RL 2000/14/EC)

AIRPROFI 703/853 - two-stage compression

- ▶ The twin-cylinder, high-performance motor with two-stage compression runs at low speed to achieve a very smooth, virtually vibration free action
- ▶ This ensures an even longer service life by reducing wear
- ▶ Equipped with an intermediate cooler in addition to the re-cooler

AIRPROFI 703/75/13 - 13 bar operating pressure

- ▶ Professional compressor with 13 bar operating pressure on a 75 l compressed air tank

Convenient safety couplings
AIRCRAFT is the first manufacturer to use this as a factory standard



One-handed safety couplings

- Two separate locking systems for maximum working safety
- Avoiding hose line backlash



Open
200 l
Tank



- Premium filter pressure regulator for continuous adjustment of the working pressure, with simultaneous dirt, oil and condensate separation
- Two pressure gauges indicate the tank and working pressure
- Three compressed air outlets for filtered compressed air, filtered and lubricated compressed air and a direct compressed air outlet on the tank
- Air take-off with **convenient quick-action safety couplings**
- Equipped as a factory standard with a premium **CONDOR pressure switch** (Fig. 230 volts)



Model	AIRPROFI 703/100	AIRPROFI 853/100	AIRPROFI 853/200	13 bar	15 bar
				AIRPROFI 703/75/13	AIRPROFI 703/100/15
Art. no.	2018731	2018831	2018832	2018734	2018735
Technical specifications					
Compressor system*	HOS	HOS	HOS	HOS	HOS
Highest flow rate	650 l/min	850 l/min	850 l/min	575 l/min	575 l/min
Fill capacity approx.	520 l/min	680 l/min	680 l/min	460 l/min	460 l/min
Maximum pressure	10 bar	10 bar	10 bar	13 bar	13(15) bar
Tank capacity	100 l	100 l	200 l	75 l	100 l
Cylinders/stages	2/2	2/2	2/2	2/2	2/2
Speed	950 rpm	1 240 rpm	1 240 rpm	850 rpm	850 rpm
Motor output	4 kW / 400 V	5.5 kW**** / 400 V	5.5 kW**** / 400 V	4 kW / 400 V	4 kW / 400 V
Weight	99 kg	112 kg	139 kg	103 kg	109 kg
Dimensions (L x W x H) in mm	1 275 x 480 x 1 015	1 275 x 480 x 1 015	1 190 x 680 x 1 150	1 020 x 440 x 1 015	1 275 x 480 x 1 015
Sound power level LWA ***	93 dB(A)	95 dB(A)	95 dB(A)	93 dB(A)	94 dB(A)

* For a description of the compressor systems refer to page 18 *** Sound power level as per DIN EN ISO 3744 (RL 2000/14/EC) **** For compressors with a motor output of 5.5 kW, please observe your local electricity utility's rules; the use of a star-delta switch may be required in some areas.

Stationary compressors - 10 bar

Our tip!

Only compress to the level you really need; after all, compressing just one "bar" more will cost 10% more energy.

Piston compressors are more economical than screw-type compressors in case of low and fluctuating compressed air requirements. Piston compressors support start/stop operation and do not have an idle mode.

K = with refrigeration dryer

KK = with refrigeration dryer, condensate drain, condensate conditioning and pre-filter



Your benefits:

- Preinstalled and ready for action
- All-round protection
- Easily transported at any time
- Integrated catchment sump
- With condensate management
- Pre-filtered compressed air

Stationary compressors - central compressed air supply systems based on a modular assembly kit

► The modular assembly kit supports the flexible composition of a compressed air supply system.

- Your benefits:**
- Customisable
 - Ability to implement a central, high-capacity compressed air supply
 - Ability to design systems for handling peak loads
 - Can be extended at any time

Compressed air system with piston compressor

- ① Piston compressor (e.g. Silent, auxiliary compressor, etc.)
- ② Water separator with condensate drain
- ③ Compressed air refrigeration dryer
- ④ Bypass line
- ⑤ Compressed air tanks
- ⑥ Condensate drain
- ⑦ Oil-water separator
- ⑧ Micro filter
- ⑨ Nanofilters
- ⑩ Activated carbon filter
- ⑪ Compressed air energy saver

As an alternative to the modular assembly kit, AIRCRAFT offers complete compressed air systems, integrated on a safety upright pallet.

Ideal for workshops where space is at a premium.



The water separator is directly downstream of the piston compressor for 99% water pre-separation. This relieves the load on the downstream devices.

99% separation of the precipitated condensate

- Your benefits:**
- Relieves the load on the downstream devices*
 - Thus reducing energy consumption
 - Better compressed air quality
 - Less pressure drop (flow-optimised)
- *e.g. Compressed air refrigeration dryer with optional bypass line

Compressed air system with screw-type compressor

- ① Screw-type compressor
- ② Water separator with condensate drain
- ③ Compressed air tanks
- ④ Automatic condensate drain
- ⑤ Condensate conditioner for oil-water separation
- ⑥ Fine filter
- ⑦ Compressed air refrigeration dryer
- ⑧ Bypass line
- ⑨ Nanofilters
- ⑩ Activated carbon filter
- ⑪ Compressed air energy saver
- ⑫ Peak load compressor

A water separator (2) is also located directly downstream of the screw-type compressor (1) for 99% water pre-separation.

The compressed air then reaches the compressed air tank (3) which is equipped with a level-controlled condensate drain (4).



From the compressed air tank it flows through a microfilter (6) to the compressed air refrigerant type dryer (7). Depending on the requirements, a nanofilter (8), for separating ultra-fine particles, and an activated carbon filter (9), for separating oil vapours, odorants, and flavourings, then follow.

Screw-type and piston compressors can be combined in a single system to cope with peak loads.

We, or our sales partners in your region, will be glad to advise you on your options for a turn-key compressed air solution. We will develop the most economical and cost-efficient solution for you.

Stationary - 10 bar

AIRSTAR Series - rugged compressors for building and trade applications with proven belt drive and two-stage, twin-cylinder, high-performance grey cast iron motors

- ▶ The twin-cylinder, high-performance motor with two-stage compression runs at low speed to achieve a very smooth, virtually vibration free action
- ▶ This ensures an even longer service life by reducing wear
- ▶ Large impeller and a cooling air baffle on the cylinder ensure optimum cooling of the compressor
- ▶ Re-cooler with cooling fins and intercooler for re-cooler ensure a low compressed air tank inlet temperature, thus reducing the moisture content of the compressed air.
- ▶ Premium electric motor with high torque
- ▶ Electric motor equipped with soft-start and motor protection switch
- ▶ Equipped with a phase inverter as standard for easy manual inversion of the sense of rotation
- ▶ Equipped with a premium **CONDOR pressure switch**
- ▶ Equipped with a pressure gauge for compressed air tank pressure and a ball valve on the compressed air tank
- ▶ The compressed air tank is equipped with a safety valve, tank pressure gauge and a condensate drain valve
- ▶ Powder-coated compressed air tank
- ▶ Equipped with all safety devices
- ▶ Complete and ready to connect
- ▶ Stable metal belt guard grille
- ▶ Including anti-vibration elements



AIRSTAR 703/270/10 H
Fig. shows the scope of delivery



AIRSTAR 703/270/10 V
Fig. shows the scope of delivery

Model	AIRSTAR 703/270/10 H	AIRSTAR 703/270/10 V
Art. no.	2028753	2028752
Technical specifications		
Compressor system*	HOS	HOS
Highest flow rate	650 l/min	650 l/min
Fill capacity 6-10 bar	520 l/min	520 l/min
Maximum pressure	10 bar	10 bar
Tank capacity	270 l	270 l
Cylinders/stages	2/2	2/2
Speed	950 rpm	950 rpm
Motor output	4 kW / 400 V	4 kW / 400 V
Weight	160 kg	160 kg
Dimensions (L x W x H) in mm	1 950 x 600 x 1 250	720 x 720 x 1 770
Sound pressure level L _{PA} **	80 dB(A)	80 dB(A)
Air outlet	3/4"	3/4"

* For a description of the compressor systems refer to page 18 ** Sound pressure level at a distance of 1 m as per DIN 45635 T 13; compressed air tank with AD 2000 design

Quality characteristics of the stationary AIRPROFI air compressors



- ▶ Quality electric motor with high torque
- ▶ Equipped with motor protection switch
- ▶ Equipped with a phase inverter as standard for easy manual inversion of the sense of rotation

- ▶ Large impeller and a cooling air baffle on the cylinder ensure optimum cooling of the compressor



- ▶ The twin-cylinder, high-performance motor with two-stage compression runs at low speed to achieve a very smooth, virtually vibration free action
- ▶ This ensures an even longer service life by reducing wear

- ▶ Stable metal belt guard grille

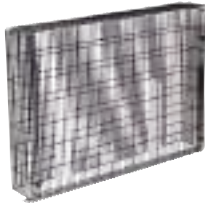

- ▶ With premium CONDOR pressure switch
- ▶ Equipped with a safety valve, a pressure gauge for compressed air tank pressure and a ball valve on the compressed air tank



- ▶ Feet including anti-vibration elements and condensate drain valve



AIRSTAR 703/270/10 V
Fig. shows upright space-saving version

- ▶ Interior and exterior of compressed air tank hot-dip galvanised



AIRPROFI 1003/500/10 H
Fig. shows horizontal version

Stationary - 10 bar

AIRPROFI V Series 10 bar - stationary compressors with an upright 270 L compressed air tank. Maximum performance on a small footprint

- ▶ The twin-cylinder, high-performance motor with two-stage compression supports low speeds to achieve a very smooth, virtually vibration free action.
- ▶ The intercooler and re-cooler ensure a low compressed air tank inlet temperature, thus reducing condensate build-up
- ▶ The large impeller ensures optimum cooling.

- ▶ Fully automatic On/Off operation
- ▶ Quality electric motors equipped with motor protection switch
- ▶ Flexible armoured hose line with heat protection avoids vibration fractures
- ▶ Three compressed air take-off points on the tank

- ▶ Interior and exterior of compressed air tank hot-dip galvanised
- ▶ Equipped with a premium **CONDOR pressure switch**
- ▶ Completely ready for connection with all fittings
- ▶ **As of 7.5 kW, equipped with an automatic star delta switch as factory standard**



AIRPROFI 853/270 V

- Scope of delivery V:**
- ▶ Star-delta switch for models as of 7.5 kW motor
 - ▶ Start-up relief
 - ▶ Anti-vibration elements

- Scope of delivery VK:**
- ▶ Star-delta switch for models as of 7.5 kW motor
 - ▶ Start-up relief
 - ▶ Anti-vibration elements
 - ▶ Safety pallet
 - ▶ Refrigeration dryer
 - ▶ Fine filter



AIRPROFI 853/270 VK

Model	AIRPROFI 703/270/10 V	AIRPROFI 853/270/10 V
Art. no.	2024712	2024812
Model	AIRPROFI 703/270/10 VK	AIRPROFI 853/270/10 VK
Art. no.	2024712 K	2024812 K
Model	AIRPROFI 703/270/10 VKK	AIRPROFI 853/270/10 VKK
Art. no.	2024712 KK	2024812 KK

Technical specifications	HOS	HOS
Compressor system*		
Highest flow rate	650 l/min	850 l/min
Fill capacity 6-10 bar	520 l/min	680 l/min
Maximum pressure	10 bar	10 bar
Tank capacity	270 l	270 l
Cylinders/stages	2/2	2/2
Speed	950 rpm	1 240 rpm
Motor output	4 kW/ 400 V	5.5 kW****/ 400 V
Weight	160 kg	170 kg
Dimensions (L x W x H) in mm**	745 x 620 x 1 870	780 x 710 x 1 870
Sound pressure level L _{PA} ***	83 dB(A)	83 dB(A)
Air outlet	3/4"	3/4"

* For a description of the compressor systems, see page 18
 ** Sound pressure level at 1 m distance as per DIN 45635 T 13
 *** Set to 13 bar switch-off pressure as a factory standard; maximum pressure of 15 bar configurable via pressure switch
 **** Please observe your local energy utility's rules for compressors with a motor output of 5.5 kW.

The perfect compressed air full service station



- Automatic condensate drain on the compressed air tank
- No unnecessary loss of compressed air thanks to level control



- Condensate conditioner WOS 1 for oil-water separation
- You will also find important notes on condensate conditioning in the compressed air treatment chapter.



- Microfilter for separating condensate and dirt with particle sizes of up to 1 micron.
- Compressed air quality as per ISO 8573-1
- As a pre-filter installed upstream of the refrigeration dryer



- K-variant equipped with a refrigeration dryer and integrated automatic condensate drain as a factory standard
- Pressure dew point at 5 °C, ambient temperature 25 °C, atmospheric dew point at -22 °C

Scope of delivery VKK:

- › Star-delta switch for models as of 7.5 kW motor
- › Start-up relief
- › Anti-vibration elements
- › Safety pallet
- › Refrigeration dryer
- › Fine filter
- › Condensate conditioner for oil-water separation WOS 1
- › Automatic condensate drain



AIRPROFI 853/270 VKK



- The twin-cylinder, high-performance motor with two-stage compression runs at low speed to achieve a very smooth, virtually vibration free action
- The large impeller ensures optimum cooling
- The low speed ensures a highly efficient air delivery performance while reducing wear.
- The intercooler and re-cooler with a large cooling fin surface area ensure a low compressed air tank inlet temperature, thus reducing condensate build-up
- Flexible, heat protected armoured hose for a long service life, as vibration breaks are ruled out

Maximum feature set on a small footprint

- ▶ The KK variant houses your complete compressed air generation and processing needs on a footprint of approx. 1 m². Delivery including safety palette.

Accessories	Art. no.
1 anti-vibration element with single-sided thread 100 x 38 mm / M10	2505640
1 anti-vibration element with two-sided thread 70 x 38 mm / 2 x M10 (for SSP)	2505650
Safety stand pallet SSP upright stationary 1,200 x 800 x 140 mm	2030103



Accessories	Art. no.
Automatic star-delta switch with operation hour counter (Mandatory in some regions as of 5.5 kW)	2506010
Electromagnetic start-up relief 24V AC normally closed	2506015
Electromagnetic start-up relief 24V AC normally open	2506017



Stationary - 10 bar

AIRPROFI H series 10 bar - stationary compressors with a horizontal compressed air tank, for maximum compressed air availability.

- ▶ The twin-cylinder, high-performance motor with two-stage compression supports low speeds to achieve a very smooth, virtually vibration free action.
- ▶ The large impeller ensures optimum cooling
- ▶ The intercooler and re-cooler ensure a low compressed air tank inlet temperature, thus reducing condensate build-up
- ▶ Premium electric motor with high torque
- ▶ Electric motor equipped with soft-start and motor protection switch
- ▶ Interior and exterior of compressed air tank hot-dip galvanised
- ▶ With premium CONDOR pressure switch
- ▶ Completely ready for connection with all fittings
- ▶ Flexible armoured hose with heat protection avoids vibration fractures
- ▶ Automatic star-delta switch with operation hour counter as of 7.5 kW models



AIRPROFI 853/100/10 H

▶ A genuine space saver with a 100 litre tank



AIRPROFI 853/200/10 H

▶ 2-cylinder compressor with 200 litre compressed air tank



AIRPROFI 853/270/10 H

▶ 2-cylinder compressor with 270 litre compressed air tank

Model AIRPROFI	703/100/10 H	853/100/10 H	853/200/10 H	703/270/10 H	853/270/10 H
Art. no.	2022273	2022283	2022284	2025712	2025812
Technical specifications					
Compressor system*	HOS	HOS	HOS	HOS	HOS
Highest flow rate	650 l/min	850 l/min	850 l/min	650 l/min	850 l/min
Fill capacity 6-10 bar	520 l/min	680 l/min	680 l/min	520 l/min	680 l/min
Maximum pressure	10 bar	10 bar	10 bar	10 bar	10 bar
Tank capacity	100 l	100 l	200 l	270 l	270 l
Cylinders/stages	2/2	2/2	2/2	2/2	2/2
Speed	950 rpm	1 240 rpm	1 240 rpm	950 rpm	1 240 rpm
Motor output	4 kW	5.5 kW****	5.5 kW***	4 kW	5.5 kW***
Weight	98 kg	110 kg	122 kg	180 kg	195 kg
Dimensions (LxWxH) in mm	1 120 x 460 x 960	1 120 x 460 x 960	1 150 x 500 x 1 150	1 190 x 600 x 1 250	1 150 x 600 x 1 240
Sound pressure level L _{PA} **	83 dB(A)	83 dB(A)	83 dB(A)	83 dB(A)	83 dB(A)
Air outlet	1/2"	1/2"	3/4"	3/4"	3/4"

*For a description of the compressor systems see page 18 **Sound pressure level at a distance of 1 m as per DIN 45635 T 13 ***Observe your local energy utility's rules for compressors with a motor output of 5.5 kW

Accessories



- Automatic condensate drain on the compressed air tank
- No unnecessary loss of compressed air thanks to level control



- Condensate conditioner WOS 1 for oil-water separation
- You will also find important notes on condensate treatment in the compressed air treatment chapter.



- Microfilter for separating condensate and dirt with particle sizes of up to 1 micron.
- Compressed air quality as per ISO 8573-1 as a pre-filter installed upstream of the refrigeration dryer



- K-variant equipped with a refrigeration dryer and integrated automatic condensate drain as a factory standard
- Pressure dew point at 5 °C, ambient temperature 25 °C, atmospheric dew point at -22 °C



AIRPROFI 1003/500/10 H

- ▶ With 500 litre tank for maximum compressed air availability



- Automatic star-delta switch with operation hour counter as of 7.5 kW models



- Premium fin-type intake filter as of AIRPROFI 1003/500/10 H

Scope of delivery AIRPROFI H:

- › Start-up relief
- › Anti-vibration elements
- › Automatic star-delta switch with operation hour counter as of 7.5 kW models

Model AIRPROFI	853/500/10 H	1003/500/10 H	1253/500/10 H
Art. no.	2025815	2025915	2026015
Technical specifications	HOS	HOS	HOS
Compressor system*			
Highest flow rate	850 l/min	950 l/min	1 200 l/min
Fill capacity 6-10 bar	680 l/min	750 l/min	900 l/min
Maximum pressure	10 bar	10 bar	10 bar
Tank capacity	500 l	500 l	500 l
Cylinders/stages	2/2	2/2	2/2
Speed	1 240 rpm	960 rpm	1 220 rpm
Motor output	5.5 kW***	5.5 kW***	7.5 kW
Weight	235 kg	245 kg	245 kg
Dimensions (L x W x H) in mm	2 020 x 570 x 1 300	2 020 x 570 x 1 340	2 020 x 570 x 1 340
Sound pressure level L _{PA} **	83 dB(A)	82 dB(A)	82 dB(A)
Air outlet	3/4"	3/4"	3/4"

* For a description of the compressor systems, see page 18 ** Sound pressure level at a distance of 1 m as per DIN 45635 T 13 *** Observe your local energy utility's rules for compressors with a motor output of 5.5 kW.

Stationary - twin systems - 10 bar

Airprofi DUO - universally deployable compressed air station with 2 x 100 l compressed air tanks, preassembled on a safety pallet, space-saving and transportable

- ▶ Two-cylinder, high-performance, two-stage compressor unit with a grey cast iron cylinder block
- ▶ Low speeds ensures a smooth, virtually vibration free action and a long service life
- ▶ The large impeller ensures optimum cooling
- ▶ Premium electric motor with high torque
- ▶ Electric motor equipped with soft-start and motor protection switch
- ▶ Equipped with a phase inverter for easy manual inversion of the sense of rotation
- ▶ Intermediate and re-coolers reduce condensate build-up
- ▶ Maintenance block with two pressure gauges for the tank and working pressure, premium **CONDOR pressure switch**
- ▶ Interior and exterior of compressed air tank hot-dip galvanised
- ▶ Fully automatic On/Off operation
- ▶ Completely ready for connection with all fittings



Duo 703/2x100/10 KK

Model	Duo 703/2x100/10
Art. no.	2023072
Model	Duo 703/2x100/10 K
Art. no.	2023073
Model	Duo 703/2x100/10 KK
Art. no.	2023074

Scope of delivery DUO:

- › Star-delta switch for models as of 7.5 kW motor
- › Start-up relief
- › Anti-vibration elements

Scope of delivery DUO K:

- › Star-delta switch for models as of 7.5 kW motor
- › Start-up relief
- › Anti-vibration elements
- › Safety pallet
- › Refrigeration dryer
- › Fine filter

Scope of delivery DUO KK:

- › Star-delta switch for models as of 7.5 kW motor
- › Start-up relief
- › Anti-vibration elements
- › Safety pallet
- › Refrigeration dryer
- › Fine filter
- › Condensate conditioner for oil-water separation
- › Automatic condensate drain

Technical specifications	
Compressor system*	HOS
Highest flow rate	650 l/min
Fill capacity	520 l/min
Maximum pressure	10 bar
Tank capacity	2 x 100 l
Cylinders/stages	2/2
Speed	950 rpm
Motor output	4 kW**** / 400 V
Weight	235 kg
Dimensions (L x W x H)	1 200 x 900 x 1 250 mm
Sound pressure level L_{PA} ***	83 dB(A)
Air outlet on compressed air tank	3/4"
Air outlet on refrigeration dryer	1/2"

* For a description of the compressor systems, see page 18

*** Sound pressure level at 1 m distance as per DIN 45635 T 13

**** Please observe your local energy utility's rules for compressors with a motor output of 5.5 kW



Duo 853/2x100/10 KK

Model	Duo 853/2x100/10
Art. no.	2023085
Model	Duo 853/2x100/10 K
Art. no.	2023086
Model	Duo 853/2x100/10 KK
Art. no.	2023087

Technical specifications	
Compressor system*	HOS
Highest flow rate	850 l/min
Fill capacity	680 l/min
Maximum pressure	10 bar
Tank capacity	2 x 100 l
Cylinders/stages	2/2
Speed	1 240 rpm
Motor output	5.5 kW**** / 400 V
Weight	235 kg
Dimensions (L x W x H) in mm	1 200 x 900 x 1 140
Sound pressure level L _{PA} ***	83 dB(A)
Air outlet on compressed air tank	3/4"
Air outlet on refrigeration dryer	1/2"

Flexibility on top

- ▶ Enabling the second compressed air tank doubles the compressed air tank volume, thus creating a greater compressed air reserve. Helps to cover short-term peaks in compressed air requirements.
- ▶ For, e.g., chisel, hammer or sandblasting work, the second tank can be isolated from the compressed air supply. This halves the tank volume helping to build up the pressure more quickly.

* For a description of the compressor systems, see page 18
 *** Sound pressure level at 1 m distance as per DIN 45635 T 13
 **** Please observe your local energy utility's rules for compressors with a motor output of 5.5 kW



K variant with refrigeration dryer

- With integrated automatic condensate drain
- Pressure dew point 5 °C, compressed air inlet temperature 35 °C, cooling air temperature 25 °C

K version with fine filter

- For separating condensate and solid contamination with particle sizes of up to 1 µm.
- Compressed air quality as per ISO 8573-1
- As a pre-filter installed upstream of the refrigeration dryer



KK version with automatic condensate drain

- Mounted on the condensate drain of the compressed air tank
- This ensures condensate separation without unnecessary pressure loss



- Condensate conditioner for oil-water separation

You will also find important notes on condensate conditioning in the compressed air treatment chapter.

AIRPROFI BK Series - auxiliary compressors provide an attractively priced option for generating additional compressed air performance, ideal as peak load compressors

- ▶ The twin-cylinder, high-performance motor with two-stage compression supports low speeds to achieve a very smooth, virtually vibration free action.
- ▶ The large impeller ensures optimum cooling
- ▶ The intercooler and re-cooler ensure a low compressed air tank inlet temperature, thus reducing condensate build-up
- ▶ Quality electric motors equipped with motor protection switch
- ▶ Ready to connect with all fittings, such as pressure switch for fully-automatic on/off switching operation, safety and non-return valves, condensate and air bleed valve for autonomous operation
- ▶ Interior and exterior of compressed air tank hot-dip galvanised
- ▶ With premium **CONDOR pressure switch**
- ▶ Completely ready for connection with all fittings

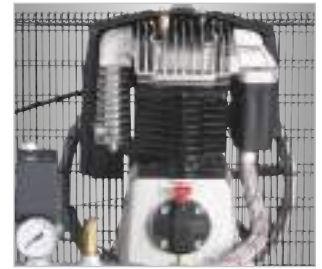

- High-performance grey cast iron motor, slow running
- A re-cooler with large-surface cooling fins ensures a low compressed air tank inlet temperature
- The flexible armoured hose line with heat protection avoids vibration fractures



Auxiliary compressors are used:

- If the existing air supply volume is insufficient
- To cope with peak loads
- Wherever it is important to provide 100% reliability
- Where legacy equipment would require expensive repairs.

Model	AIRPROFI BK 703/13/10	AIRPROFI BK 1003/13/10
Art. no.	2029711	2029911

Technical specifications	HOS	HOS
Compressor system*	HOS	HOS
Highest flow rate	650 l/min	960 l/min
Fill capacity 6-10 bar	520 l/min	750 l/min
Maximum pressure	10 bar	10 bar
Tank capacity	13 l	13 l
Cylinders/stages	2/2	2/2
Speed	950 rpm	1 060 rpm
Motor output	4 kW/ 400 V	5.5 kW****/400 V
Weight	55 kg	80 kg
Dimensions (L x W x H) in mm	685 x 745 x 675	685 x 790 x 745
Sound pressure level L _{PA} ***	83 dB(A)	83 dB(A)
Air outlet	3/4"	3/4"

* For a description of the compressor systems, see page 18

*** Sound pressure level at 1 m distance as per DIN 45635 T 13

**** Please observe your local energy utility's rules for compressors with a motor output of 5.5 kW

Recommended accessories

AIRCRAFT compressed air tank arrays as 2x or 4x arrays for up to 400 litres of addition air volume

See page 117 for more details

Our tip!

Only compress to the level you really need; after all, compressing just one “bar” more will cost 10% more energy.

Piston compressors are more economical than screw-type compressors in case of low and fluctuating compressed air requirements. Piston compressors support start/stop operation and do not have an idle mode.

K = with refrigeration dryer

KK = with refrigeration dryer, condensate drain, condensate conditioning and pre-filter



Stationary - 13 - 15 bar

AIRPROFI Series 13 and 15 bar - Stationary compressors with an upright or horizontal compressed air tank, for operating pressures above 10 bar.

- ▶ The twin-cylinder, high-performance motor with two-stage compression supports low speeds to achieve a very smooth, virtually vibration free action.
- ▶ The large impeller ensures optimum cooling
- ▶ The intercooler and re-cooler ensure a low compressed air tank inlet temperature, thus reducing condensate build-up
- ▶ Quality electric motors equipped with motor protection switch
- ▶ Flexible armoured hose with heat protection avoids vibration fractures
- ▶ Interior and exterior of compressed air tank hot-dip galvanised

- ▶ Equipped with a premium **CONDOR pressure switch**
- ▶ Completely ready for connection with all fittings

AIRPROFI 703/75/13 H

- ▶ With 75 litre tank
- ▶ Professional compressor with 13 bar operating pressure
- ▶ This gives you 13 bar operating pressure
- ▶ A switch-off pressure of 13 bar is typical in practical applications

Additional equipment for "K" type:

- ▶ Refrigeration dryer for dry compressed air ensuring a longer service life of compressed air tools and avoiding failure of pneumatic controls
- ▶ With an automatic condensate drain



AIRPROFI 703/270/15 V

Scope of delivery V:

- ▶ Star-delta switch for models as of 7.5 kW motor
- ▶ Start-up relief
- ▶ Anti-vibration elements

Scope of delivery VK:

- ▶ Star-delta switch for models as of 7.5 kW motor
- ▶ Start-up relief
- ▶ Anti-vibration elements
- ▶ Safety pallet
- ▶ Refrigeration dryer
- ▶ Fine filter



AIRPROFI 753/270/15 VK

Model	AIRPROFI 703/270/15 V	AIRPROFI 753/270/15 V****
Art. no.	2024752	2024852

Model	AIRPROFI 703/270/15 VK	AIRPROFI 753/270/15 VK****
Art. no.	2024752 K	2024852 K

Model	AIRPROFI F 703/270/15 VKK	AIRPROFI 753/270/15 VKK****
Art. no.	2024752 KK	2024852 KK

Technical specifications	HOS	HOS
Compressor system*	HOS	HOS
Highest flow rate	575 l/min	750 l/min
Fill capacity	460 l/min	525 l/min
Maximum pressure***	13(15) bar	13(15) bar
Tank capacity	270 l	270 l
Cylinders/stages	2/2	2/2
Speed	850 rpm	785 rpm
Motor output	4 kW	5.5 kW
Weight	190 kg	190 kg
Dimensions (L x W x H)	745 x 620 x 1 870 mm	850 x 710 x 1 950 mm
Sound pressure level L _{pA} **	83 dB(A)	82 dB(A)
Air outlet	3/4"	3/4"

Scope of delivery VKK:

- ▶ Star-delta switch for models as of 7.5 kW motor
- ▶ Start-up relief
- ▶ Anti-vibration elements
- ▶ Safety pallet
- ▶ Refrigeration dryer
- ▶ Fine filter
- ▶ Condensate conditioner for oil-water separation WOS 1
- ▶ Automatic condensate drain

Maximum feature set on a small footprint

- The KK variant houses your complete compressed air generation and processing needs on a footprint of approx. 1 m².



AIRPROFI 753/270/15

* For a description of the compressor systems refer to page 18 ** Sound pressure level at a distance of 1 m as per DIN 45635 T 13

*** Set to 13 bar switch-off pressure as a factory standard; maximum pressure of 15 bar configurable via pressure switch

**** Please observe your local energy utility's rules for compressors with a motor output of 5.5 kW.

Accessories



- Automatic condensate drain on the compressed air tank
- No unnecessary loss of compressed air thanks to level control

Accessories



- Condensate conditioner WOS 1 for oil-water separation
- You will also find important notes on condensate conditioning in the compressed air treatment chapter.

Accessories



- Microfilter for separating condensate and dirt with particle sizes of up to 1 micron.
- Compressed air quality as per ISO 8573-1
- As a pre-filter installed upstream of the refrigeration dryer

Accessories



- K-variant equipped with a refrigeration dryer and integrated automatic condensate drain as a factory standard
- Pressure dew point at 5 °C, ambient temperature 25 °C, atmospheric dew point at -22 °C



AIRPROFI 703/75/13 H



AIRPROFI 903/500/15 H

- ▶ With 500 litre tank
- ▶ For maximum compressed air availability



- Automatic star-delta switch with operation hour counter for 7.5 kW and 11 kW models

Model	AIRPROFI 703/75/13 H	AIRPROFI 703/270/15 H	AIRPROFI 753/270/15 H	AIRPROFI 903/500/15 H
Art. no.	2022275	2025752	2025852	2025955

Technical specifications	HOS	HOS	HOS	HOS
Compressor system*	HOS	HOS	HOS	HOS
Highest flow rate	575 l/min	575 l/min	750 l/min	1030 l/min
Fill capacity	460 l/min	460 l/min	525 l/min	765 l/min
Maximum pressure	13 bar	13 (15) bar***	13 (15) bar***	13 (15) bar***
Tank capacity	75 l	270 l	270 l	500 l
Cylinders/stages	2/2	2/2	2/2	2/2
Speed	850 rpm	850 rpm	785 rpm	1 050 rpm
Motor output	4 kW	4 kW	5.5 kW****	7.5 kW
Weight	103 kg	210 kg	215 kg	300 kg
Dimensions(LxWxH) in mm	850 x 460 x 960	1 190 x 600 x 1 250	1 190 x 600 x 1 320	2 020 x 570 x 1 340
Sound pressure level L _{PA} **	79 dB(A)	83 dB(A)	82 dB(A)	82 dB(A)
Air outlet	3/4"	3/4"	3/4"	3/4"

Scope of delivery AIRPROFI H:

- > Start-up relief
- > Anti-vibration elements
- > Automatic star-delta switch with operation hour counter as of 7.5 kW models

* For a description of the compressor systems refer to page 18 ** Sound pressure level at a distance of 1 m as per DIN 45635 T 13
 *** Set to 13 bar switch-off pressure as a factory standard; maximum pressure of 15 bar configurable via pressure switch
 **** Please observe your local energy utility's rules for compressors with a motor output of 5.5 kW

Stationary - 13 bar

Airprofi DUO - universally deployable compressed air station with 2 x 75 litre compressed air compressed air tanks, preassembled on a safety pallet, space-saving and transportable

- ▶ Two-cylinder, high-performance, two-stage compressor unit with a grey cast iron cylinder block
- ▶ Low speeds ensures a smooth, virtually vibration free action and a long service life
- ▶ The large impeller ensures optimum cooling
- ▶ Quality electric motors equipped with motor protection switch
- ▶ Equipped with a phase inverter for easy manual inversion of the sense of rotation
- ▶ Intermediate and re-coolers reduce condensate build-up
- ▶ Maintenance block with two pressure gauges for the tank and working pressure, premium **CONDOR pressure switch**
- ▶ Fully automatic On/Off operation
- ▶ Completely ready for connection with all fittings
- ▶ Interior and exterior of compressed air tank hot-dip galvanised



DUO 703/2X75/13

Model	Duo 703/2x75/13
Art. no.	2023185
Model	Duo 703/2 x 75/13 K
Art. no.	2023186
Model	Duo 703/2x75/13 KK
Art. no.	2023187

Scope of delivery DUO:

- > Star-delta switch for models as of 7.5 kW motor
- > Start-up relief
- > Anti-vibration elements

Scope of delivery DUO K:

- > Star-delta switch for models as of 7.5 kW motor
- > Start-up relief
- > Anti-vibration elements
- > Safety pallet
- > Refrigeration dryer
- > Fine filter

Scope of delivery DUO KK:

- > Star-delta switch for models as of 7.5 kW motor
- > Start-up relief
- > Anti-vibration elements
- > Safety pallet
- > Refrigeration dryer
- > Fine filter
- > Condensate conditioner for oil-water separation
- > Automatic condensate drain

Technical specifications	
Compressor system*	HOS
Highest flow rate	575 l/min
Fill capacity	460 l/min
Maximum pressure	13 bar
Tank capacity	2 x 75 L
Cylinders/stages	2/2
Speed	850 rpm
Motor output	4 kW**** / 400 V
Weight	230 kg
Dimensions (L x W x H) in mm	1 200 x 900 x 1 140
Sound pressure level L _{PA} ***	79 dB(A)
Air outlet on compressed air tank	3/4"
Air outlet on refrigeration dryer	1/2"

* For a description of the compressor systems, see page 18
 *** Sound pressure level at 1 m distance as per DIN 45635 T 13
 **** Please observe your local energy utility's rules for compressors with a motor output of 5.5 kW



DUO 703/2 X 75/10 KK



Duo 703/2 x 75/10 KK

Flexibility on top

- ▶ Enabling the second compressed air tank doubles the compressed air tank volume, thus creating a greater compressed air reserve
- ▶ Helps to cover short-term peaks in compressed air requirements
- ▶ For, e.g., chisel, hammer or sandblasting work, the second tank can be isolated from the compressed air supply. This halves the tank volume helping to build up the pressure more quickly.



K variant with refrigeration dryer

- With integrated automatic condensate drain
- Pressure dew point 5 °C, compressed air inlet temperature 35 °C, cooling air temperature 25 °C

K version with fine filter

- For separating condensate and solid contamination with particle sizes of up to 1 µm.
- Compressed air quality as per ISO 8573-1
- As a pre-filter installed upstream of the refrigeration dryer



KK version with automatic condensate drain

- Mounted on the condensate drain of the compressed air tank
- This ensures condensate separation without unnecessary pressure loss



- Condensate conditioner for oil-water separation

You will also find important notes on condensate conditioning in the compressed air treatment chapter.

AIRPROFI BK series - with inexpensive auxiliary compressors generate additional compressed air performance, ideal as peak load compressors

- ▶ The twin-cylinder, high-performance motor with two-stage compression supports low speeds to achieve a very smooth, virtually vibration free action.
- ▶ The large impeller ensures optimum cooling
- ▶ The intercooler and re-cooler ensure a low compressed air tank inlet temperature, thus reducing condensate build-up
- ▶ Quality electric motors equipped with motor protection switch
- ▶ Ready to connect with all fittings, such as pressure switch for fully-automatic on/off switching operation, safety and non-return valves, condensate and air bleed valve for autonomous operation
- ▶ Interior and exterior of compressed air tank hot-dip galvanised



AIRPROFI BK 703/13/15



- ① High-performance grey cast iron motor, slow running
- ② With premium CONDOR pressure switch for fully-automated on/off operation

- ③ Interior and exterior of compressed air tank hot-dip galvanised
- ④ Flexible armoured hose line with heat protection avoids vibration fractures

Auxiliary compressors are used:

- ▶ If the existing air supply volume is insufficient
- ▶ To cope with peak loads
- ▶ Wherever it is important to provide 100% reliability
- ▶ Where legacy equipment would require expensive repairs.

Model	AIRPROFI BK 703/13/15	AIRPROFI BK 753/13/15
Art. no.	2029751	2029851
Technical specifications	HOS	HOS
Compressor system*	HOS	HOS
Highest flow rate	575 l/min	750 l/min
Fill capacity	460 l/min	525 l/min
Maximum pressure**	13(15) bar	13(15) bar
Tank capacity	13 l	13 l
Cylinders/stages	2/2	2/2
Speed	850 rpm	785 rpm
Motor output	4 kW/ 400 V	5.5 kW****/400 V
Weight	55 kg	75 kg
Dimensions (L x W x H) in mm	685 x 745 x 675	685 x 790 x 745
Sound pressure level L _{PA} ***	83 dB(A)	82 dB(A)
Air outlet	3/4"	3/4"

* For a description of the compressor systems, see page 18

** Set to 13 bar switch-off pressure as a factory standard; maximum pressure of 15 bar configurable via pressure switch

*** Sound pressure level at 1 m distance as per DIN 45635 T 13

**** Please observe your local energy utility's rules for compressors with a motor output of 5.5 kW.

**We help you save - 13 bar instead of 15 bar!

Our 15 bar compressors are preset to 13 bar switch-off pressure as a factory standard. The reason for this is that 90 % of all users only require a max. operating pressure of 13 bar.

Any pressure generated above this value means additional energy consumption of about 8 % per bar.

But if you do require the maximum pressure of 15 bar, you can set it via the pressure switch at any time.



AIRPROFI Silent Series

Compressors, noise-insulated

AIRPROFI 321/100 Silent - low-noise, mobile compressors with twin-cylinder V motor directly flanged on

- ▶ Featuring a Silent noise-insulation housing and newly developed noise-reducing air filters
- ▶ Designed for users who need a quiet working environment
- ▶ Intermediate and re-coolers reduce condensate build-up
- ▶ Premium electric motor equipped with motor protection switch

- ▶ Equipped with a filter pressure regulator and pressure gauge, and a **CONDOR pressure switch**
- ▶ Completely ready for connection with all fittings
- ▶ Fully automatic On/Off operation
- ▶ Air outlets equipped with **premium quick-action safety couplings** as standard

- ▶ Two pressure gauges for the compressed air tank and working pressure
- ▶ The compressed air tank is equipped with a safety valve, tank pressure gauge and a condensate drain valve
- ▶ Premium compressed air tank hot-dip galvanised on interior and exterior
- ▶ Equipped with all safety devices



· Easier draining of condensate thanks to **ball valve installed as standard**



- ▶ Sophisticated motor design
- ▶ Twin-cylinder V motor with single-stage compression
- ▶ Extremely slow runner
- ▶ Flanged on, no loss of energy between the motor and the compressor
- ▶ This improves the efficiency and fill performance, while prolonging the service life



AIRPROFI 321/100 Silent

- ▶ Silent noise-insulation housing additionally equipped with temperature-controlled fan



Model	AIRPROFI 321/100 SILENT
Art. no.	2022300

Technical specifications	
Compressor system*	HOS
Highest flow rate	310 l/min
Fill capacity approx.	240 l/min
Maximum pressure	10 bar
Tank capacity	100 l
Cylinders/stages	2/1
Speed	1 420 rpm
Motor output	2.2 kW/ 230 V
Weight	88 kg
Dimensions (L x W x H) in mm	1 275 x 480 x 930
Sound power level L_{WA} **	82 dB(A)
Air outlet	3/4"

* For a description of the compressor systems, see page 18

** Sound power level as per DIN EN ISO 3744 (RL 2000/14/EC)

AIRPROFI SILENT Series - Stationary compressors with noise-insulating housings - Ideal for deployment directly in the work environment

- ▶ Designed for professional and industrial applications in which a quiet work environment is essential
- ▶ Features a Silent noise-insulation housing for deployment in sensitive areas
- ▶ The twin-cylinder, high-performance motor with two-stage compression allows for very low speeds. This helps to achieve a very smooth, virtually vibration-free action
- ▶ With premium CONDOR pressure switch
- ▶ Service-friendly layout

- ▶ Large fan flywheel and large impeller ensure optimum cooling
- ▶ Intermediate and re-cooler, in combination with an additional air duct between the motor and the compressor, reduce condensate build-up
- ▶ Premium electric motor equipped with motor protection switch
- ▶ The belt can be adjusted from the outside
- ▶ Fully automatic On/Off operation
- ▶ Equipped with all safety devices
- ▶ Completely ready for connection with all fittings

- ▶ **For 10 bar models:** as of 7.5 kW, equipped with an automatic star delta switch as factory standard
- ▶ **For 15 bar models:** as of 5.5 kW, equipped with an automatic star delta switch as factory standard



AIRPROFI Silent
Low noise emission of 67 db(A) - very quiet.



AIRPROFI 853/10 Silent



AIRPROFI 853/270/10 H Silent

- ▶ Interior and exterior of compressed air tank hot-dip galvanised
- ▶ Stationary Silent models equipped as a factory standard with a pressure switch for fully-automatic switching on/off, motor circuit breaker, relief valve, pressure gauge and start-up relief,
- ▶ With non-return valve, condensate drain, ball valve and anti-vibration elements

Equipment level

AIRPROFI 853/10 Silent

- › Motor protection switch
- › Pressure gauge
- › On/Off switch
- › Operating hours counter
- › Electrical control unit
- › Start-up relief
- › Anti-vibration elements

Model	AIRPROFI 853/10 SILENT	AIRPROFI 853/270/10 H SILENT	AIRPROFI 1003/10 SILENT	AIRPROFI 1003/500/10 H SILENT	AIRPROFI 903/15 SILENT	AIRPROFI 903/500/15 H SILENT
Art. no.	2022801	2022831	2022850	2022860	2022855	2022865

Technical specifications	AIRPROFI 853/10 SILENT	AIRPROFI 853/270/10 H SILENT	AIRPROFI 1003/10 SILENT	AIRPROFI 1003/500/10 H SILENT	AIRPROFI 903/15 SILENT	AIRPROFI 903/500/15 H SILENT
Compressor system*	HOS	HOS	HOS	HOS	HOS	HOS
Highest flow rate	850 l/min	850 l/min	1 080 l/min	1 080 l/min	900 l/min	900 l/min
Fill capacity	680 l/min	680 l/min	845 l/min	845 l/min	675 l/min	675 l/min
Maximum pressure	10 bar	10 bar	10 bar	10 bar	15 bar	15 bar
Tank capacity	-	270 l	-	500 l	-	500 l
Cylinders/stages	2/2	2/2	2/2	2/2	2/2	2/2
Speed	1 240 rpm	1 240 rpm	1 100 rpm	1 100 rpm	920 rpm	920 rpm
Motor output	5.5 kW*** / 400 V	5.5 kW*** / 400 V	7.5 kW / 400 V	7.5 kW / 400 V	7.5 kW / 400 V	7.5 kW / 400 V
Weight	155 kg	250 kg	180 kg	364 kg	180 kg	410 kg
Dimensions (L x W x H) in mm	790 x 790 x 720	1 690 x 790 x 1 410	930 x 790 x 830	2 020 x 790 x 1 610	930 x 790 x 830	2 020 x 790 x 1 610
Sound pressure level L _{PA} **	67 dB(A)	67 dB(A)	73 dB(A)	73 dB(A)	70 dB(A)	70 dB(A)
Air outlet	3/4"	3/4"	3/4"	3/4"	3/4"	3/4"

* For a description of the compressor systems refer to page 18 ** Sound pressure level at a distance of 1 m as per DIN 45635 T 13

*** Please observe your local energy utility's rules for compressors with a motor output of 5.5 kW

Screw-type compressors



Easy option for installing an exhaust air duct

- ▶ Exhaust air ducting to top or side
- ▶ Heat recovery option (p. 110)



Clean conditions in any ambient

- ▶ A cabinet pre-filtering panel (from PLUS) prevents the dust coming inside increasing air filters and belt life by 15 %.



Best possible power transmission from the motor to the compressor

- ▶ Premium ribbed belt
- ▶ Long service life.



Low-noise cooling

- ▶ Intensive cooling guarantees operating safety and a low noise level
- ▶ Very quiet thanks to thermostatically controlled radial fan



Smart control and monitoring system

- EasyTRONIC MICRO II (ETM II)**
- ▶ In models from 2.2 to 4 kW
- EasyTRONIC IV (ET IV)**
- ▶ In models from 5.5 to 75 kW
 - ▶ With sense of direction check (except MICRO SE)



Easy maintenance

- ▶ Oil filter and oil microfilter separator cartridge are bolted on elements and easily accessible through the front panel
- ▶ Easy removal and installation of all critical components



Maximum safety, even at high temperatures

- ▶ All oil lines are rubber hoses with steel mesh armoring



High energy saving

- ▶ High quality components
- ▶ Low power consumption
- ▶ Efficient performance.
- ▶ Low CO₂ emissions



Innovation, quality and economy - our prime objectives!



Precision measuring centre P 26



■ Quality for many years

In close partnership AIRCRAFT markets screw-type compressors by the renowned compressor manufacturer FINI. For many years, FINI has manufactured screw-type compressor stages and a full range of important components for screw compressors. The entire production process takes place at its Italian plants and is perfectly integrated thanks to the latest generation tool machines and advanced testing equipment, thus ensuring a high quality standard. A team of highly specialised engineers, dedicated to constantly developing and monitoring the produced compressor stages and designing of new components, ensures maximum reliability and flexible use. Ten different compressor stages models and a comprehensive range of accessories such as intake regulators and integrated systems for minimum pressure valves, oil filters and air de-oiling units, ensure the global success of the company and have made it one of the leading brands in industrial compressed air.

■ The unique ReVerso Profile

The compressor stages are characterised by rotors with an optimised profile and outstanding performance. The production process is completely integrated, thanks to the latest generation machines and advanced testing equipment to ensure a quality standard at the highest level. The unique ReVerso profile of the compressor stages (a FINI patent) allows the unit to be driven by the main and auxiliary rotors. This unique property means that all planning needs can be met, both in terms of performance and with respect to drive system based on electric motors or internal combustion engines.

■ Maximum precision and repeatability

A CAD system for solid modelling enables optimisation of the component layout and assessment of their strength. The cross section of each rotor is built up in four precision-machining steps that help to achieve the highest levels of precision in implementation and repeatability. Due to this high level of structural precision each main rotor matches any auxiliary rotor. All parts are 100 % factory tested before they reach the market. The compressor stages especially are individually tested after assembly and a second time after they have been installed on the complete machine. The performance of each individual element is recorded in the production database, to enable full traceability. Our own state-of-the-art production systems for the screw modules guarantee long-term reliability and premium quality.

■ Reliable and efficient solutions

The design philosophy involves simplifying the mechanical parts. The most reliable and efficient solutions are chosen. For many years, models have thus been manufactured with coaxial, gearless direct drives, maximising the performance and reliability of the screw-type compressors. In each new development the same high standards apply in terms of performance and reliability. This means that AIRCRAFT can offer a series of compressors with a direct drive system that is unique on the market.

Profile grinding machine GT 500 H



The ACS power unit – a small power pack with nine parameters and great user-friendliness!

Microprocessor-monitored control

- ▶ Guarantees reliability and efficiency
- ▶ Controls direct start with charging/idle cycle
- ▶ Permanent monitoring of the direction of rotation - particularly in case of changing deployment locations
- ▶ Anti-condensation system
- ▶ Service interval display



Menu button 1 / Parameter values for total working hours

Menu button 2 / Parameter values for system temperature

Start-stop button / Alarm reset button

Number	Parameter	Task
1	Standby mode	If no air is needed, the compressor remains in standby mode for 180 seconds* and then stops
2	System temperature	Below 60°C* , the system does not stop after standby
3	Max. temperature	At a temperature of more than 100°C* , an alarm is output and the compressor stops
4	Fan temperature	At a temperature of more than 75°C* , the electric fan is activated
5	Max. system pressure	As of 10 bar* , the compressor switches to vent mode
6	Min. system pressure	Below 7 bar* , the compressor switches to charge mode
7	Maintenance hours	Defined period between service intervals (500 hours*)
8	Maintenance reset	Maintenance is reset
9	Missing maintenance hours	Shows the hours remaining until the next maintenance

* Default values



- ▶ Maintenance friendly thanks to easily accessible components such as the oil filter, air/oil separator and oil fill screw
- ▶ Anti-condensate system: Oil heater: Electronic oil temperature control prevents condensate formation and keeps the oil in the optimal operating temperature range

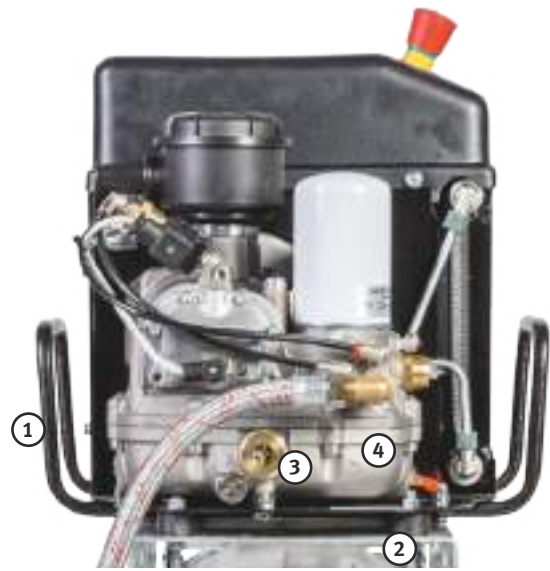

1. Bumper bar at side protects air-end against knocks
2. Power unit mounted on vibration-damping rubber feet
3. Easily accessible oil drain plug for fast and easy draining of the oil
4. Very compact design - power unit dimensions are 549 x 425 x 411 mm

Maintenance intervals for ACS 2.7 and ACS 3.5

1 000 h * (or every year)	2 000 h * (or every year)	8 000 h	20 000 h
<ul style="list-style-type: none"> · 1 Air filter cartridge · 1 Oil filter cartridge · 1 separator filter · High Performance oil ISO 46 	<p>as per 1 000 h plus:</p> <ul style="list-style-type: none"> · Drive o-ring 	<p>as per 2 000 h plus:</p> <ul style="list-style-type: none"> · Minimum pressure valve · Thermostatic valve · Intake control · Motor bearing · "Packsmart shaft seal" maintenance kits 	<p>as per 2 000 h plus:</p> <ul style="list-style-type: none"> · "Packsmart shaft seal" maintenance kits · Bearing maintenance kits
0206N11L0100	0206N11L0161	0206N11L0283	0206N11L0163

Designation	Art. no.	Designation	Art. no.
1 000 h maintenance kit	0206N11L0100	8 000 h maintenance kit	0206N11L0283
2 000 h maintenance kit	0206N11L0161	20 000 h maintenance kit	0206N11L0163

ACS mobile – compact, lightweight and quiet, with maximum equipment level

- ▶ Directly driven, extremely quiet, screw-type compressor
- ▶ For mobile use
- ▶ Suitable for continuous operations
- ▶ Dump valve evacuates excess air in continuous operation
- ▶ Heater attached to compressor keeps the oil constantly at operating temperature for optimal viscosity
- ▶ With operating hour counter

Electronic control K-Tronic 5

- Guarantees reliability and efficiency
- ▶ Direct start with charging/idle cycle
- ▶ Anti-condensation system
- ▶ Microprocessor-monitored control
- ▶ Monitors the direction of rotation
- ▶ Service interval display

Premium equipment

- ▶ Steering chassis with parking brakes and large, puncture-resistant PU foam wheels for comfortable transport without lifting

- ▶ Flexible armoured hose with heat protection prevents vibration breaks
- ▶ Splash water protected as per IP 54
- ▶ 400-volt model equipped with phase inverter for easy manual inversion of the direction of rotation
- ▶ Interior and exterior of pressure vessel hot-dip galvanised
- ▶ Equipped with all safety devices
- ▶ Complete and ready to connect



ACS 3.5-10-100

Model		ACS 2.7-10-100	ACS 3.5-10-100
Art. no.		2066110	2066120
Technical specifications			
Effective delivery volume	l/min	240	360
Maximum pressure	bar		10
Vessel capacity	l		100
Degree of protection			IP54
Speed	rpm	2 800	2 880
Motor output	kW	2.7	3.5
Supply voltage	V	230 *	400
Connection		1/2" ball valve	
Weight	kg	92	97
Dimensions (L x W x H)	mm	1 400 x 450 x 1 000	
Sound pressure level Lp **	dB(A)	65	69

* For 230 V models C16 circuit breakers are required as the mains fuse

** Sound pressure level at 1 m distance as per DIN 45635 T 13

Designation	Art. no.
5 litres of oil "High Performance Oil ISO 46"	0206L09N3000

New

GE start

Function:

- ▶ Limits the start-up current and prevents fuses tripping

Technical details:

- ▶ For machines up to 3 500 W
- ▶ Splash proof plastic housing and sockets
- ▶ Built-in check/function indicator
- ▶ **2 sockets:**
- ▶ One for start-up current limiting – the other works like a domestic socket for less powerful machines, such as drills or inspection lamps
- ▶ Operating voltage: 230 Volt / 50, 60 Hz
- ▶ Fully-electronic, i.e., no wear parts such as relays
- ▶ Suitable for capacitor motors



Accessories	Art. no.
Start-up current limiter with soft start GE start	2509901

ACS stationary – compact models

- ▶ Directly driven, extremely quiet, screw-type compressor
- ▶ Suitable for continuous operations
- ▶ Heater attached to compressor keeps the oil constantly at operating temperature for optimal viscosity
- ▶ Automatic on/off operation
- ▶ Dump valve evacuates excess air in continuous operation
- ▶ With operating hour counter

K-Tronic5 electronic control

- ▶ Guarantees reliability and efficiency
- ▶ Direct start with charging/idle cycle
- ▶ Anti-condensation system
- ▶ Programmable standby times
- ▶ Monitors the direction of rotation
- ▶ Service interval display
- ▶ 3/8" ball valve fitted as standard for easy draining

Premium equipment

- ▶ With phase inverter on connector as factory standard
- ▶ Splash water protected as per IP 54
- ▶ Flexible armoured hose with heat protection prevents vibration breaks
- ▶ Equipped with all safety devices
- ▶ 200 l vessel as per AD 2000
- ▶ Interior and exterior of pressure vessel hot-dip galvanised



ACS 3.5-10-200

Model		ACS 3.5-10-200	ACS 3.5-10-200 K
Art. no.		2066220	2066221
Technical specifications			
Effective delivery volume	l/min	360	
Maximum pressure	bar	10	
Vessel capacity	l	200	
Degree of protection		IP54	
Speed	rpm	2 880	
Motor output	kW	3.5	
Supply voltage	V	400	
Air outlet		3/4" ball valve	
Weight	kg	122	146
Dimensions (L x W x H)	mm	1 180 x 680 x 1 090	1 180 x 680 x 1 090
Sound pressure level Lp *	dB(A)	69	

Equipment level	ACS	ACS K
Anti-vibration elements	X	X
Safety pallet	X	X
Refrigeration dryer		X
Fine filter		X

* Sound pressure level at a distance of 1 m as per DIN 45635 T 13

Designation	Art. no.
5 litres of oil "High Performance Oil ISO 46"	0206L09N3000



ACS K

- With refrigeration dryer and integrated automatic condensate drain
- Pressure dew point 5 °C, compressed air inlet temperature 35 °C, cooling air temperature 25 °C



ACS K

- Fine filter as prefilter upstream of the refrigeration dryer for separating condensate and solid contamination with a particle size of up to 1 µm (compressed air quality as per ISO 8573-1)



ACS 3.5-10-200 K

Service

Maintenance intervals for ACS 2.7 and ACS 3.5

	1 000 h * (or every year)	2 000 h * (or every year)	8 000 h	20 000 h
	<ul style="list-style-type: none"> · 1 Air filter cartridge · 1 Oil filter cartridge · 1 separator filter · High Performance oil ISO 46 	<p>as per 1 000 h plus:</p> <ul style="list-style-type: none"> · Drive o-ring 	<p>as per 2 000 h plus:</p> <ul style="list-style-type: none"> · Minimum pressure valve · Thermostatic valve · Intake control · Motor bearing · "Packsmart shaft seal" maintenance kits 	<p>as per 2 000 h plus:</p> <ul style="list-style-type: none"> · "Packsmart shaft seal" maintenance kits · Bearing maintenance kits
ACS 2.7 / ACS 3.5	0206N11L0100	0206N11L0161	0206N11L0283	0206N11L0163

Designation	Art. no.
1 000 h maintenance kit	0206N11L0100
2 000 h maintenance kit	0206N11L0161

Designation	Art. no.
8 000 h maintenance kit	0206N11L0283
20 000 h maintenance kit	0206N11L0163

Screw-type compressors

New

Airprofi DUO – universally deployable compressed air station with 2 x 100 l compressed air pressure vessels, preassembled on a safety pallet, space-saving and transportable

- ▶ Directly driven, extremely quiet, screw-type compressor
- ▶ Suitable for continuous operations
- ▶ Heater attached to compressor keeps the oil constantly at operating temperature for optimal viscosity
- ▶ Dump valve evacuates excess air in continuous operation
- ▶ With operating hour counter

K-Tronic5 electronic control

- ▶ Guarantees reliability and efficiency
- ▶ Direct start with charging/idle cycle
- ▶ Anti-condensation system
- ▶ Programmable standby times
- ▶ Monitors the direction of rotation
- ▶ Service interval display

Premium equipment

- ▶ With direction of rotation monitoring and phase-inverter on connector as standard
- ▶ Splash water protected as per IP 54
- ▶ Flexible armoured hose with heat protection prevents vibration breaks
- ▶ Equipped with all safety devices
- ▶ Interior and exterior of pressure vessel hot-dip galvanised

Flexibility on top

- ▶ Enabling the second compressed air vessel doubles the pressure vessel volume, thus creating a greater compressed air reserve
- ▶ Helps to cover short-term peaks in compressed air requirements
- ▶ For, e.g., chisel, hammer or sandblasting work, the second vessel can be isolated from the compressed air supply. This halves the vessel volume helping to build up the pressure more quickly.



ACS DUO 3.5-10 2 x 100



ACS DUO 3.5-10 2 x 100 K

Model	ACS DUO 3.5-10 2 x 100	ACS DUO 3.5-10 2 x 100 K	ACS DUO 3.5-10 2 x 100 KK
Art. no.	2066420	2066421	2066422

Technical specifications		ACS DUO 3.5-10 2 x 100	ACS DUO 3.5-10 2 x 100 K	ACS DUO 3.5-10 2 x 100 KK
Effective delivery volume	l/min	360		
Maximum pressure	bar	10		
Vessel capacity	l	2 x 100		
Degree of protection		IP54		
Speed	rpm	2 880		
Motor output	kW	3.5		
Supply voltage	V	400		
Air outlet		One single-hand quick coupling		
Weight	kg	176	200	201
Dimensions (L x W x H)	mm	1 200 x 900 x 1 100	1 200 x 900 x 1 120	1 200 x 900 x 1 150
Sound pressure level L _{PA} **	dB(A)	69		

Equipment level	DUO	DUO K	DUO KK
Start-up relief	X	X	X
Anti-vibration elements	X	X	X
Safety pallet	X	X	X
Refrigeration dryer		X	X
Fine filter		X	X
Condensate conditioner for oil-water separation			X
Automatic condensate drain			X

*Sound pressure level at a distance of 1 m as per DIN 45635 T 13

Designation	Art. no.
5 litres of oil "High Performance Oil ISO 46"	0206L09N3000



DUO equipment
1. Anti-vibration elements
2. Safety pallet



DUO K equipment
1. Refrigeration dryer with integrated automatic condensate drain, pressure dew point 5 °C, compressed air inlet temperature 35 °C, cooling air temperature 25 °C
2. Fine filter as prefilter upstream of the refrigeration dryer for separating condensate and solid contamination with a particle size of up to 1 µm (compressed air quality as per ISO 8573-1)



DUO KK equipment
1. Condensate conditioner for oil-water separation
2. Automatic condensate drain installed on the pressure vessel, condensate drainage without unnecessary pressure loss

ACS power units – reliable and efficient power units



Model	ACS 2.7-10	ACS 3.5-10
Art. no.	2066100	2066200
Technical specifications		
Effective delivery volume	240 l/min	360 l/min
Maximum pressure	10 bar	10 bar
Speed	2 800 rpm	2 880 rpm
Motor output	2.7 kW / 230 V**	3.5 kW / 400 V
Weight	43 kg	45 kg
Dimensions (L x W x H)	550 x 430 x 420 mm	550 x 430 x 420 mm
Sound pressure level L _{PA} **	65 dB(A)	69 dB(A)

* Sound pressure level at a distance of 1 m as per DIN 45635 T 13



ACS AIRCAR – compact and mobile, specially equipped for the building site

- ▶ Directly driven, extremely quiet, screw-type compressor
- ▶ Suitable for continuous operations
- ▶ Suitable for use in building and trade applications at temperatures between 5°C and 45°C, e.g., in the workshop, or for interior construction work and building shell construction
- ▶ Heater attached to compressor keeps the oil constantly at operating temperature for optimal viscosity
- ▶ Dump valve evacuates excess air in continuous operation
- ▶ With operating hour counter

Electronic control K-Tronic 5

- Guarantees reliability and efficiency
- ▶ Direct start with charging/idle cycle
- ▶ Anti-condensation system
- ▶ Monitors the direction of rotation
- ▶ Service interval display

Specially equipped for the building site

- ▶ Three compressed air outlets with single-hand safety couplings on the control panel: one for filtered compressed air, one for filtered and lubricated compressed air, and a direct compressed air outlet from the pressure vessel

- ▶ The frame provides space for storing tools as well as all-round protection for all sensitive components
- ▶ Splash water protected as per IP 54
- ▶ Flexible armoured hose with heat protection prevents vibration breaks
- ▶ Puncture-resistant PU foam wheels and broad wheelbase ensure comfortable and safe transport
- ▶ Supplied with a protected hose hook on the inside
- ▶ Powder-coated compressed air vessel

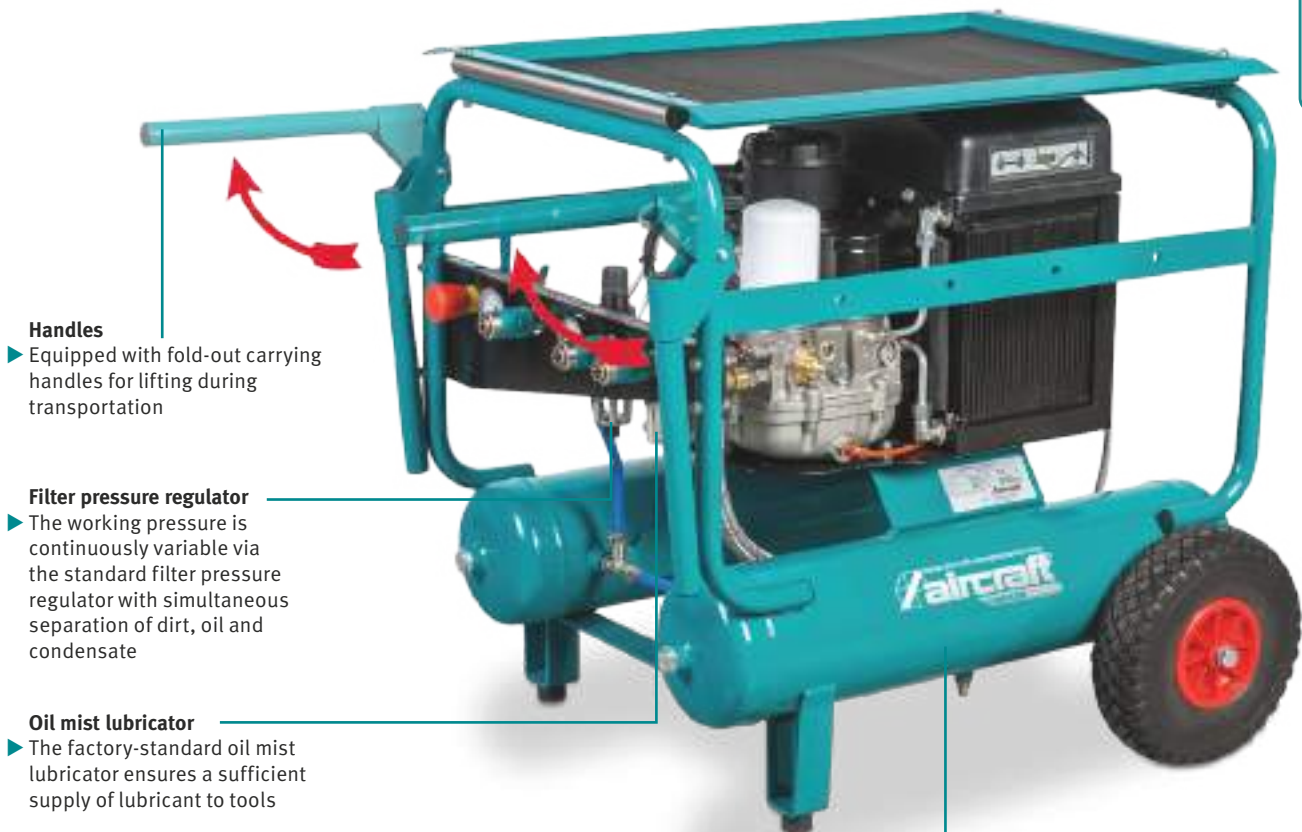

- Handles**
- ▶ Equipped with fold-out carrying handles for lifting during transportation
- Filter pressure regulator**
- ▶ The working pressure is continuously variable via the standard filter pressure regulator with simultaneous separation of dirt, oil and condensate
- Oil mist lubricator**
- ▶ The factory-standard oil mist lubricator ensures a sufficient supply of lubricant to tools

ACS AIRCAR 2.7-10-22

- High quality pressure vessel**
- ▶ Powder coated compressed air vessels

Model		ACS AIRCAR 2.7-10-22	ACS AIRCAR 3.5-10-22
Art. no.		2066310	2066320
Technical specifications			
Effective delivery volume	l/min	240	360
Maximum pressure	bar		10
Vessel capacity	l		22
Degree of protection			IP54
Speed	rpm	2 800	2 880
Motor output	kW	2.7	3.5
Supply voltage	V	230 **	400
Air outlet		Three single-handed safety couplings	
Weight	kg	83	88
Length x width x height	mm	1 020 x 700 x 720	
Sound pressure level L _{PA} **	dB(A)	65	69

* Sound pressure level at a distance of 1 m as per DIN 45635 T 13

** For 230 V models C16 circuit breakers are required as the mains fuse

Designation	Art. no.
5 litres of oil "High Performance Oil ISO 46"	0206L09N3000

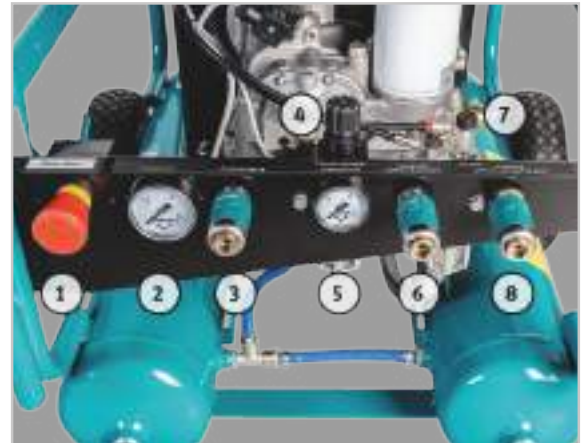

Control panel

Ergonomically positioned, clearly structured and self-explanatory

1. Easily accessible emergency stop switch with protection at top
2. Pressure gauge for displaying the vessel pressure
3. Compressed air direct outlet from compressed-air vessel
4. Filter pressure regulator for adjusting the working pressure
5. Pressure gauge for displaying the configured working pressure
6. Compressed air outlet for filtered compressed air
7. Oil mist lubricator for a metred supply of lubricant to tools
8. Compressed air outlet for filtered and lubricated compressed air



Protection function

- ▶ The frame provides space for storing tools as well as all-round protection for the various sensitive components
- ▶ The tubular frame and the top-mounted tray provide perfect protection against damage to fittings.

Hose hook

- ▶ Supplied with a protected hose hook on the inside
- ▶ The hose is not included in the scope of delivery



Chassis

- ▶ The large stable wheels and **puncture proof tyres made of PU foam** in combination with the wide wheelbase ensure safe and convenient transportation even on uneven surfaces such as staircases

Base

- ▶ There are no fittings or switches in the base area that could suffer damage when tilting or transporting the compressor

Service

Maintenance intervals for ACS 2.7 and ACS 3.5

	1 000 h * (or every year)	2 000 h * (or every year)	8 000 h	20 000 h
	<ul style="list-style-type: none"> · 1 Air filter cartridge · 1 Oil filter cartridge · 1 separator filter · High Performance oil ISO 46 	<p>as per 1 000 h plus:</p> <ul style="list-style-type: none"> · Drive o-ring 	<p>as per 2 000 h plus:</p> <ul style="list-style-type: none"> · Minimum pressure valve · Thermostatic valve · Intake control · Motor bearing · "Packsmart shaft seal" maintenance kits 	<p>as per 2 000 h plus:</p> <ul style="list-style-type: none"> · "Packsmart shaft seal" maintenance kits · Bearing maintenance kits
ACS 2.7 / ACS 3.5	0206N11L0100	0206N11L0161	0206N11L0283	0206N11L0163
Designation	Art. no.	Designation	Art. no.	
1 000 h maintenance kit	0206N11L0100	8 000 h maintenance kit	0206N11L0283	
2 000 h maintenance kit	0206N11L0161	20 000 h maintenance kit	0206N11L0163	

A-MICRO – A-PLUS

Our TARGET: efficiency, energy saving, modularity

- ▶ The new belt-driven oil injected A-MICRO- und A-PLUS screw-type compressors have been designed to minimize energy costs, without sacrificing performances.
- ▶ The modularity and flexibility of these products provide multiple solutions suitable for different user's requirements: with or without tank, with or without dryer, in fixed or variable speed version.



Why an AIRCRAFT screw-type compressors?

- ▶ Lower operating costs
- ▶ Modern
- ▶ Compact
- ▶ Robust
- ▶ Reliable
- ▶ Extremely quiet
- ▶ Efficient
- ▶ Energy saving



State-of-the-art precision manufacturing of the compressors for uncompromising quality products



Compressor

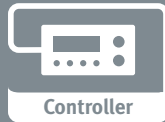

Controller

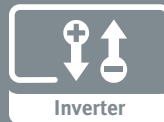

Inverter

Energy savings thanks to frequency controlled air compressors



- ▶ Today, the reduction of the energy consumption has become a global challenge in terms of environmental impact.
- ▶ Reducing power consumption and protecting our valuable energy resources represents one of the greatest global environmental challenges of our times.
- ▶ The A-PLUS series, with an output of 22, 37, 55 and 75 kW, is also available in speed controlled version, providing high performance combined with energy saving solutions. The graph below shows the significant energy saving using variable speed compressors in a typical installation.

- ▶ The use of a frequency inverter able to dynamically adjust the voltage/frequency/current values of the motor, helps to eliminate unnecessary power losses by constantly adjusting the amount of compressed air generated to match the actual air requirement, offering many proven advantages to the user:
- ▶ Continuous control of the motor speed and compressed air generation to precisely match the air requirement.
- ▶ The air output is constantly adjusted between 40 % and 100 % of the compressor full capacity.
- ▶ Constant and accurate air pressure control selectable at any value between 6 and 10 bar (13 bar on demand).
- ▶ Energy consumption is proportional to the delivered compressed air.

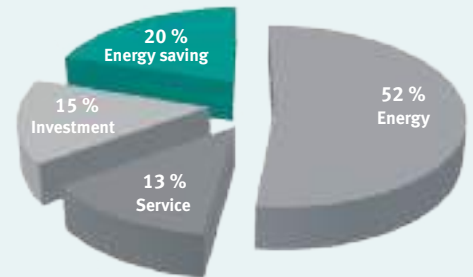
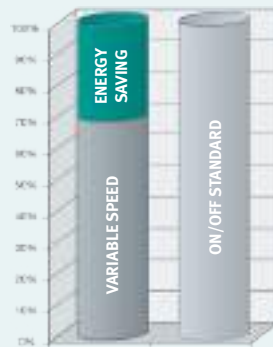

MANAGEMENT COSTS

Overview of the series



▶ Floor mounted

▶ Includes pressure vessel

▶ Includes pressure vessel and dryer

▶ Variable speed

EasyTRONIC control

The smart control and monitoring system

EasyTRONIC MICRO II (ETM II)

Installed on models from 2.2 to 4 kW.

- ▶ Four maintenance timers (air cartridge, oil, oil filter, oil separator).
- ▶ Automatic re-start after a power failure.
- ▶ Cooling fan temperature configurable.
- ▶ Compressor remote start settable.
- ▶ Integrated phase sequence relay.



Controller with multi-function backlight display, the menu is alphanumeric type. In the main screen are displayed:

- ▶ Working pressure (no load/load);
- ▶ Oil temperature
- ▶ Total working hours;
- ▶ On-load working hours;
- ▶ Compressor status LED (stand-by, offload, load);
- ▶ Hours remaining before maintenance

EasyTRONIC IV (ET IV)

Installed on models from 5.5 to 75 kW.

- ▶ Remote monitoring (on request) GSM/GPRS/ Ethernet/WiFi module (for on-line compressor status, remote support, connection with PC, smartphone and tablet, connection between neighbouring compressors).



Master/slave function (for non-frequency-controlled machines)

- ▶ It is possible to connect up to four compressors and distribute the workload to balance the operating hours. The target pressures of the various air compressors are dynamically changed.
- ▶ Precondition: All devices have FININUAIR controllers!



Controller with multi-function backlight display, the menu is alphanumeric type. In the main screen are displayed:

- ▶ Working pressure (no load/load);
- ▶ Oil temperature
- ▶ Compressor status (standby, no load, load);
- ▶ Fan status (off/on);
- ▶ Date and time
- ▶ Hours remaining before maintenance
- ▶ Inverter use percentage



Noise level overview



Master controller

EASY X4 sequence controller

Many compressed air stations include several compressors: EasyX4 is a weekly programmable controller, capable of configuring up to four compressors, based on the amount of air actually required.

EasyX4 is the easiest solution for compressor

workflow sequencing and monitoring complex compressor systems with up to four fixed- or variable-speed compressors.

The programming is intuitive. It is sufficient to set the four pressure ranges (assuming that four is the number of connected units) and then define

at what time the entire compressor station will be switched on and off; at the same time, define the pressure at which each compressor needs to operate.

Three programming levels:

- ▶ **MANUAL:** compressors are fixed to a given operational pressure range;
- ▶ **AUTOMATIC:** with pressure range swapping after a programmable time interval;
- ▶ **GROUP PROGRAMMING:** where compressors can be switched within groups.



Compressor status	Meaning
x	Compressor disabled in current program
o	Compressor in standby
•	Compressor pressurised
• flashing	Compressor idling
A	Compressor with alarm status, not responding to start command

The menus have the classical structure of pull-down menus. The title is at the top, followed by a list of parameters or the available subfolders. The parameters are distinguished from the subfolders by a numerical value displayed next to them. You can use the **▲** and **▼** buttons to scroll the functions or parameters until the desired entry is found. The arrows top right show whether more entries exist above or below the displayed entry. After selecting the desired parameter or desired function, you can press the **■** button to access the corresponding menu or, in

the case of a parameters, make a change. If you are modifying a parameter, the value displayed next to it starts to flash. It can be changed using the **▲** and **▼** keys. To confirm a selected value, press the **■** button.

Pressing the **◀** button lets you go back to the previous menu. The parameter value is not confirmed.

Model	EASY X4
Art. no.	0405531604

Technical specifications	
Supply voltage	230 V AC ±15 %
Frequency	50/60 Hz
Max. consumption at 24 V AC	200 mA
Relay outputs	4 NC
Max. current relay	8 A res.
Digital inputs	4 + shared connection
Analogue inputs 4-20 mA	1 (12 bit)
Battery	CR2032



Functional description

Once the EASY X4 sequence controller has power, the system boots and implements the operating conditions that existed when it was switched off: "Standby" or "Active".

In "Standby" mode, the compressors are not released for operation; it is only in this mode that you can press the button to access the menus.

In "active" operating mode, however, the EASY X4 sequence controller switches the compressors to reflect the modes and times defined by the active program and based on the pressure that exists in the system and measured by the pressure transducer.

In "Standby" mode, you can press the Start (I) button to switch the EASY X4 sequence controller to system initialisation status.

If the system pressure drops below the value entered as the [MinPressure] parameter, the compressor defined by the value [Sel. Compr:] is enabled for a time defined by the [Fill time:] parameter (this parameter can be accessed via the [Settings.] menu; cf. section "Setting the functions"). The system can thus be filled when empty (a typical example is switching on every morning), where a single compressor is used to avoid switching on all the machine connected to the EASY X4 sequence controller.

After the fill time, the EASY X4 sequence controller performs the programs entered by the user depending on the pressure and the programs active at all times and every day.

Full details of the machine status are shown on the main screen.

The possible states are: Standby, pressurised, empty, disabled and alarm state. See the "Main screen" section for a description of the symbols that indicate these states.

A malfunction occurs when the feedback on the status of the remote line switch of the active compressor (for more information on the type of message, see the "Installation" section) does not reach the EASY X4 sequence controller within the time set by the matching [Time Feedb:] parameter in the [Settings.] menu.

To prevent several compressors starting up at the same time, you can use the [Start delay:] parameter to enable starting of two successive compressors with an intermediate delay. This helps to avoid electrical overload. The EASY X4 sequence controller can be switched to "Standby" status at any time by pressing the Stop (O) button. All compressors now switch to idle mode, and stop after the idle time set on the individual machines or the local controller. See the compressor manufacturer's documentation for reading or changing this value.

If the **controller does not have a power supply**, the control contacts on the compressor remain closed, that is, the compressors are released for operation. This is an emergency function that allows the compressors to be operated even if they are not serviced by the EASY X4 sequence controller for external reasons (interrupted power supply, etc.). The compressors are thus operated directly in line with the pressure setpoints defined by the individual controllers or pressure monitors. See the compressor documentation for reading or changing these values.

The operating pressure ranges that are set directly on the individual controllers or pressure monitors must be higher than the pressure ranges set on the EASY X4 sequence controller.

This rules out interaction with the operating logic of the EASY X4 sequence controller.

Additionally, "emergency operation" of the compressor is ensured in case of a malfunction of the EASY X4 sequence controller.

For example, if pressure ranges between 8.8 bar and 9.7 bar are set at the EASY X4 sequence controller, then the controllers or pressure monitors on the compressors must be set to below the minimum pressure value at 8.7 bar and above the maximum value at 9.8 bar.

In all cases, the pressure loss between the EASY X4 sequence controller converter installation position and the pressure measured upstream of the compressor converter must be taken into consideration.

Example: If a pressure loss of 0.4 bar is measured between the EASY X4 sequence controller converter installation position and the compressors with the system running (without a compressed air flow, the pressure loss will be zero), the compressors would need to operate at a pressure that is 0.4 bar higher taking this example into consideration. For this reason, the maximum operating pressure of the air compressors would need to be set to a value that exceeds 10.2 bar (9.8 + 0.4). This pressure might even exceed the maximum operating pressure of the air compressor themselves.

Connecting plan

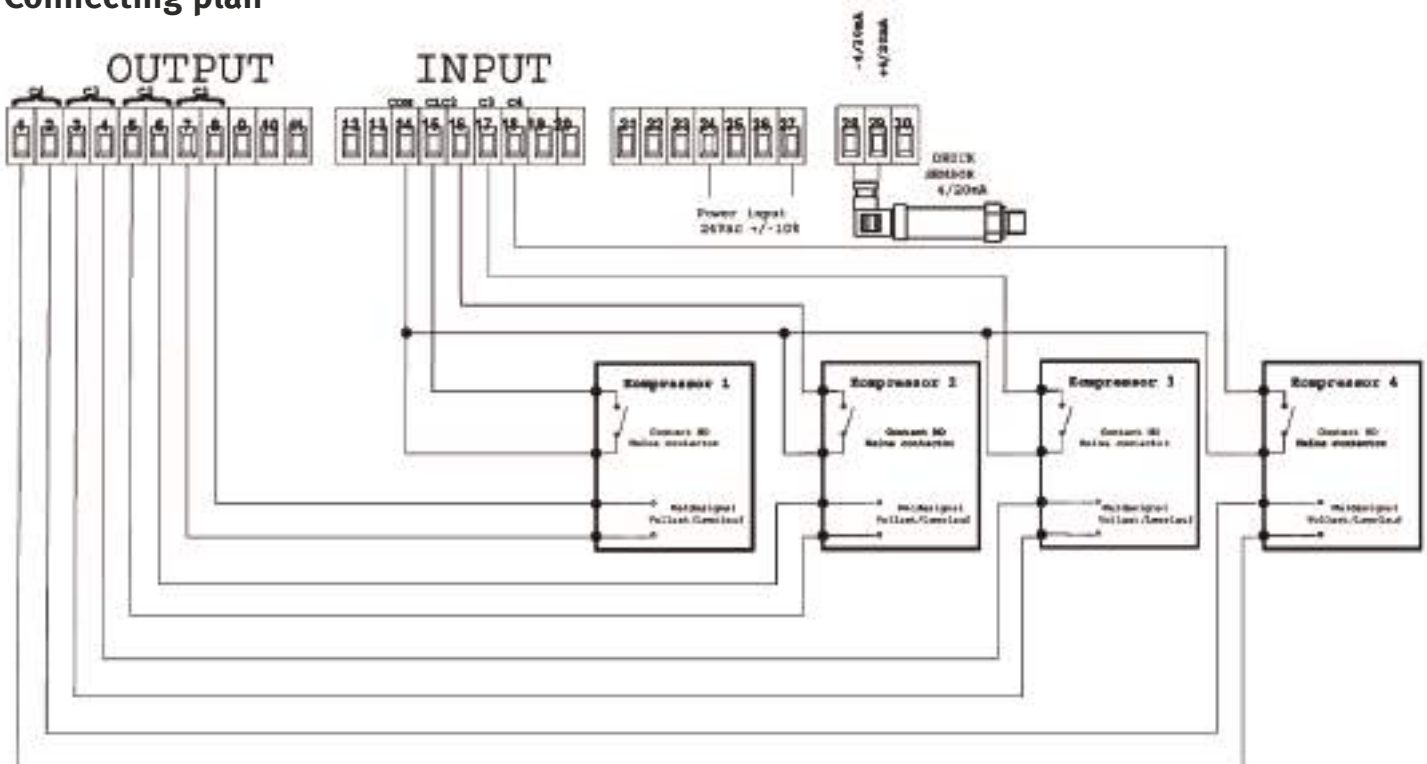

A-MICRO SE 2.2 – 4.0: simple, silent and economical.



- ▶ The A-MICRO range is available in two versions:
- ▶ **A-MICRO "SE" 2.2 - 4 kW:** Electromechanical on/off switch with motor protection and sense of direction check. The pressure gauge and operating hour counter are included in the control panel. Easy to use, no idle running means considerable energy saving.
- ▶ **A-MICRO 4 - 5.5 kW:** star-delta circuitry, including ETM II electronic controller, which controls the complete operation of the machine including rotation direction checking

- ▶ Enabling the second vessel doubles the pressure vessel volume, thus creating a greater compressed air reserve
- ▶ Helps to cover short-term peaks in compressed air requirements
- ▶ For, e.g., chisel, hammer or sandblasting work, the second vessel can be isolated from the compressed air supply. This halves the vessel volume helping to build up the pressure more quickly.

A-MICRO SE 2.2 - 4.0

2.2-4 kW

Available versions:

- floor mounted compressor
- Compressor + vessel
- Compressor + vessel + refrigeration dryer (vessel: 200 litres)

Air-end:

FS14



Controller:

- On/off pressure switch

Fixed Speed
1 500 rpm at 230 Volt ; 3 000 rpm at 400 Volt

A-DUO-MICRO SE 4.0

4 kW

Available versions:

- Compressor + vessel
- Compressor + vessel (2 x 100l) + refrigeration dryer
- Compressor + vessel (2 x 100 l) + refrigeration dryer + fine filter + oil water separator + autom. condensate drain

Air-end:

FS14



Controller:

- On/off pressure switch

Fixed Speed
3 000 rpm at 400 Volt



- ▶ Extremely quiet
- ▶ Very compact design
- ▶ Incl. sense of direction check
- ▶ Low maintenance costs
- ▶ Ease of installation and use.

▶ Energy saving



Dryer module ▶
The models with tank are also available with a dryer ("K" versions): immediately ready to operate without any installation overhead.



A-MICRO 4.0-5.5

4 - 5.5 kW

Available versions:

- floor mounted compressor
- Compressor + vessel
- Compressor + vessel + refrigeration dryer (vessel: 270 or 500 litres)

Air-end:

FS14



Controller:

EasyTRONIC MICRO II (ETM II)



Fixed Speed
3 000 rpm at 400 Volt

A-MICRO SE series – Screw-type compressors with ribbed belt drive in noise-insulated housing. For permanent operations, even with low compressed air requirements.

- ▶ Space-saving, ribbed belt-driven stand-alone compressors
- ▶ Start-stop operation via pressure switch achieves energy savings compared with idling control
- ▶ Specially designed for operations with continuous compressed requirements where a compact, low-noise device with low operating costs is desirable
- ▶ Highly efficient noise-insulation allows for deployment in sensitive areas
- ▶ Intensive cooling guarantees operational safety and good air quality
- ▶ Equipped with a star delta circuitry as factory standard as of 4 kW motor output
- ▶ Also ideal to supplement existing systems, e.g., for covering the basic compressed air load
- ▶ With sense of direction check
- ▶ Includes thermal motor protection, oil temperature monitoring (max. 110°C) and operating hours counter as a factory standard, thus guaranteeing a high level of operational safety
- ▶ Service-friendly thanks to optimum accessibility and easy removal and installation of all critical components
- ▶ Permanent protection against corrosion thanks to hot-dip galvanised vessel



A-MICRO SE 4.0-10

- ▶ Fig. shows open front cover
- ▶ Service-friendly thanks to optimum accessibility and easy removal and installation of all critical components

A-MICRO SE 4.0-08-200

- ▶ Permanent protection against corrosion thanks to hot-dip galvanised vessel

Type	Maximum pressure	Effective delivery volume	Motor output		Volts	Noise	Dimensions (LxWxH)	Connection	Vessel capacity	Weight	Art. no.
	bar		l/min	kW							
Model range A-MICRO SE - Screw-type compressors with ribbed belt drive (floor-mounted)**											
A-MICRO SE 2.2-10 M	10	240	2.2	3	230	58	580 x 480 x 760	1/2"	-	87	2091004
A-MICRO SE 4.0-08 (IE3)	8	580	4	5.5	400	60	580 x 480 x 760	1/2"	-	93	2091602
A-MICRO SE 4.0-10 (IE3)	10	485	4	5.5	400	60	580 x 480 x 760	1/2"	-	93	2091604
Model range A-MICRO SE - Screw-type compressors with ribbed belt drive on vessel											
A-MICRO SE 2.2-10 M - 200	10	240	2.2	3	230	58	1 440 x 510 x 1 280	1/2"	200	144	2091014
A-MICRO SE 4.0-08-200 (IE3)	8	580	4	5.5	400	60	1 440 x 510 x 1 280	1/2"	200	150	2091612
A-MICRO SE 4.0-10-200 (IE3)	10	485	4	5.5	400	60	1 440 x 510 x 1 280	1/2"	200	150	2091614

*Sound pressure level at a distance of 1 m as per DIN 45635 T 13 ** Use of an overflow valve recommended in screw-type compressor operations without pressure vessel - available as an accessory



- Intensive cooling guarantees operational safety and good air quality
- Extremely quiet fan by design



- Premium ribbed belt drive guarantees optimum power transmission from the motor to the compressor ensuring a long service life at the same time



A-MICRO SE 4.0-08-200 K (IE3)

► On vessel with add-on refrigeration dryer

Type	Maximum pressure bar	Effective delivery volume l/min	Motor output		Volts	Noise in dB(A)*	Dimensions (LxWxH) mm	Connection G	Vessel capacity l	Weight kg	Art. no.
			kW	PS							
Model range A-MICRO SE - Screw-type compressors with ribbed belt drive on vessel with built-on refrigeration dryer											
A-MICRO SE 4.0-08-200 K	8	580	4	5.5	400	60	1 440 x 510 x 1 280	1/2"	200	180	2091652
A-MICRO SE 4.0-10-200 K	10	485	4	5.5	400	60	1 440 x 510 x 1 280	1/2"	200	180	2091654

A-DUO-MICRO Series - 4 kW screw-type compressor with ribbed belt drive and 2 x 100 l vessels on safety pallet

- ▶ Screw-type compressor with ribbed belt drive
- ▶ Start-stop operation via pressure switch achieves energy savings compared with idling control
- ▶ Minimal and easy maintenance
- ▶ Completely ready for connection with all fittings
- ▶ Hot dip galvanised pressure vessel



A-DUO-MICRO SE 4.0-10 2 x 100

▶ Figure shows standard type

A-DUO-MICRO SE 4.0-10 2 x 100 K

▶ Easily transportable and deployable thanks to the safety pallet.

Scope of delivery DUO:

Anti-vibration elements

Scope of delivery DUO K:

Anti-vibration elements

Safety pallet

Refrigeration dryer

Fine filter

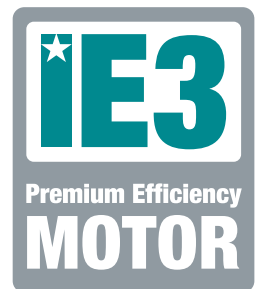

Type	Maximum pressure bar	Effective delivery volume l/min	Motor output kW PS	Volts	Noise in dB(A)*	Dimensions (LxWxH) mm	Connection G	Vessel capacity l	Weight kg	Art. no.
Model range A-DUO MICRO - Screw-type compressor with ribbed belt drive on 2 x 100 l vessel										
A-DUO-MICRO SE 4.0-08 2x100	8	580	4.0 5.5	400	61	1 250 x 950 x 1 430	1/2"	2 x 100	198	2091622
A-DUO-MICRO SE 4.0-10 2x100	10	485	4.0 5.5	400	61	1 250 x 950 x 1 430	1/2"	2 x 100	198	2091624
Model range A-DUO MICRO K - Screw-type compressors with ribbed belt drive with built-on refrigeration dryer on 2 x 100 l vessel										
A-DUO-MICRO SE 4.0-08 2x100 K	8	580	4.0 5.5	400	61	1 250 x 950 x 1 430	1/2"	2 x 100	221	2091662
A-DUO-MICRO SE 4.0-10 2x100 K	10	485	4.0 5.5	400	61	1 250 x 950 x 1 430	1/2"	2 x 100	221	2091664
A-DUO MICRO KK Series - central compressed air system with 2x100 l pressure vessel. Refrigeration dryer, automatic condensate drain, pre-filter and condensate conditioner for oil-water separation										
A-DUO-MICRO SE 4.0-08 2x100 KK	8	580	4.0 5.5	400	61	1 250 x 950 x 1 430	1/2"	2 x 100	228	2091682
A-DUO-MICRO SE 4.0-10 2x100 KK	10	485	4.0 5.5	400	61	1 250 x 950 x 1 430	1/2"	2 x 100	228	2091684

*Sound pressure level at a distance of 1 m as per DIN 45635 T 13



- Automatic condensate drain on vessel



- Condensate conditioner for oil-water separation



- Microfilter installed as filter upstream of compressed air take-off for separating condensate and solid dirt with particles of up to 1 µm
- Compressed air quality as per ISO 8573-1

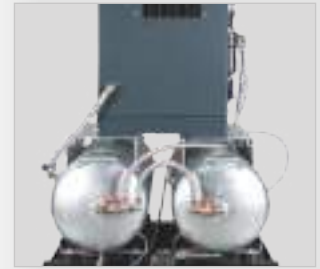

- **KK variant** with automatic condensate drain as a factory standard
- for reliable and economic condensate draining without unnecessary compressed air loss



A-DUO-MICRO SE 4.0-10 2 x 100 KK

Flexibility on top

- ▶ Enabling the second compressed air vessel doubles the pressure vessel volume, thus creating a greater compressed air reserve. Helps to cover short-term peaks in compressed air requirements.
- ▶ For, e.g., chisel, hammer or sandblasting work, the second vessel can be isolated from the compressed air supply. This halves the vessel volume helping to build up the pressure more quickly.

Scope of delivery DUO KK:

Anti-vibration elements
Safety pallet
Refrigeration dryer
Pre-/fine filter AFF0078
Autom. condensate drain AMD
Oil/water separator AOWT 2



- Screw-type compressor with ribbed belt drive
- Minimum energy consumption
- Very quiet

A-MICRO series – Screw-type compressors with ribbed belt drive in noise-insulated housing. For permanent operations, even with low compressed air requirements.

- ▶ Space-saving, ribbed belt-driven stand-alone compressors
- ▶ ETM II controller incl. sense of direction checking
- ▶ Specially designed for operations with continuous compressed requirements where a compact, low-noise device with low operating costs is desirable
- ▶ Highly efficient noise-insulation allows for deployment in sensitive areas
- ▶ Intensive cooling guarantees operational safety and good air quality
- ▶ Also ideal to supplement existing systems, e.g., for covering the basic compressed air load
- ▶ Includes thermal motor protection, oil temperature monitoring (max. 110°C) and operating hours counter as a factory standard, thus guaranteeing a high level of operational safety
- ▶ Service-friendly thanks to optimum accessibility and easy removal and installation of all critical components
- ▶ Permanent protection against corrosion thanks to hot-dip galvanised vessel



A-MICRO 4.0-10

- ▶ Service-friendly thanks to optimum accessibility and easy removal and installation of all critical components



A-MICRO 4.0-10 - 200

Type	Maximum pressure bar	Effective delivery volume l/min	Motor output		Noise in dB(A)*	Dimensions (LxWxH) mm	Connection G	Vessel capacity l	Weight kg	Art. no.
			kW	PS						
A-MICRO model range - Screw-type compressors with ribbed belt drive (floor-mounted)**										
A-MICRO 4.0-08 (IE3)	8	580	4	5.5	60	580 x 480 x 760	1/2"	–	94	2091602-S
A-MICRO 4.0-10 (IE3)	10	485	4	5.5	60	580 x 480 x 760	1/2"	–	94	2091604-S
A-MICRO 4.0-13 (IE3)	13	330	4	5.5	60	580 x 480 x 760	1/2"	–	94	2091606-S
A-MICRO 5.5-08 (IE3)	8	720	5.5	7.5	64	600 x 520 x 780	1/2"	–	125	2091802
A-MICRO 5.5-10 (IE3)	10	650	5.5	7.5	64	600 x 520 x 780	1/2"	–	125	2091804
A-MICRO 5.5-13 (IE3)	13	485	5.5	7.5	64	600 x 520 x 780	1/2"	–	125	2091806
A-MICRO model range - Screw-type compressors with ribbed belt drive on vessel										
A-MICRO 4.0-08-200 (IE3)	8	580	4	5.5	60	1 440 x 510 x 1 280	1/2"	200	151	2091612-S
A-MICRO 4.0-10-200 (IE3)	10	485	4	5.5	60	1 440 x 510 x 1 280	1/2"	200	151	2091614-S
A-MICRO 5.5-08-270 (IE3)	8	720	5.5	7.5	64	1 560 x 570 x 1 390	1/2"	270	185	2091822
A-MICRO 5.5-10-270 (IE3)	10	650	5.5	7.5	64	1 560 x 570 x 1 390	1/2"	270	185	2091824

*Sound pressure level at a distance of 1 m as per DIN 45635 T 13 ** Use of an overflow valve recommended in screw-type compressor operations without pressure vessel - available as an accessory



- Intensive cooling guarantees operational safety and good air quality
- Extremely quiet fan by design



- Premium ribbed belt drive guarantees optimum power transmission from the motor to the compressor ensuring a long service life at the same time



A-MICRO 5.5-08-270 K (IE3)

Type	Maximum pressure bar	Effective delivery volume l/min	Motor output		Noise in dB(A)*	Dimensions (LxWxH) mm	Connection G	Vessel capacity l	Weight kg	Art. no.
			kW	PS						
A-MICRO model range - Screw-type compressors with ribbed belt drive on vessel with built-on refrigeration dryer										
A-MICRO 4.0-08-200 K (IE3)	8	580	4	5.5	60	1 440 x 510 x 1 280	1/2"	200	181	2091652-S
A-MICRO 4.0-10-200 K (IE3)	10	485	4	5.5	60	1 440 x 510 x 1 280	1/2"	200	181	2091654-S
A-MICRO 5.5-08-270 K (IE3)	8	720	5.5	7.5	64	1 560 x 570 x 1 390	1/2"	270	215	2091862
A-MICRO 5.5-10-270 K (IE3)	10	650	5.5	7.5	64	1 560 x 570 x 1 390	1/2"	270	215	2091864

A-PLUS 7 - 22 kW: new design, high performance.

► All important components of the compressor are machined in-house with highly innovative process controlled machines: this allows full control on the production cycle and over the total quality of the complete compressor.

► The cooling air flow, channeled by the thermostatic controlled centrifugal fan, cools down a generously dimensioned combined oil/air heat exchanger: this permits the compressor to run also in severe temperature conditions.



- Extremely quiet
- Low maintenance costs
- Ease of installation and use.
- High-performance screw air-ends
- Ease of access for routine maintenance
- Pre-filtering panel

◀ **Dryer module**
The Plus 18.5, 22, 31 and 38 models with dryer module (ES) provide clean, dry air that improves the system's reliability, avoids costly downtime and production delays, and safeguards the quality of the final product.

A-PLUS 8-11-15

A-PLUS 18.5-22

7.5 - 15 kW

18.5 - 22 kW

Available versions:

- floor mounted compressor
- Compressor + vessel
- Compressor + vessel + refrigeration dryer
(Vessel: 270 or 500 litres)

Available versions:

- Base compressor
- Compressor + refrigeration dryer

Air-end:

FS26 TF



Air-end:

FS50 TF



Controller:

EasyTRONIC MICRO II (ETM II)



Controller:

EasyTRONIC IV (ET IV)



Fixed Speed

Fixed or variable speed (A-Plus 22 VS)

A-PLUS 30 - 75 kW: a quality choice.

- ▶ Extremely quiet
- ▶ High-performance screw air-ends
- ▶ Ease of access for routine maintenance
- ▶ Low maintenance costs
- ▶ Ease of installation and use.
- ▶ Pre-filtering panel

Clean conditions in any ambient
A cabinet pre-filtering panel (standard from 18.5 kW) prevents the dust coming inside increasing air filters and belt life by 15 %.



A-PLUS 31-38



A-PLUS 45-55



A-PLUS 56-75

30-37 kW

Available versions:

- Base compressor
- Compressor + refrigeration dryer

Air-end:

FS100
FS130



Controller:

EasyTRONIC IV (ET IV)



Fixed or variable speed
(A-Plus 38 VS)

45-55 kW

Available versions:

- Base compressor

Air-end:

FS130



Controller:

EasyTRONIC IV (ET IV)



Fixed Speed

55-75 kW

Available versions:

- Base compressor

Air-end:

FS250



Controller:

EasyTRONIC IV (ET IV)



Fixed or variable speed
(A-Plus 56 and A-Plus 75 VS)

A-Plus series - belt-driven screw-type compressors for permanent operation and 100 % load - designed for maximum operating safety.

- ▶ Thanks to direct coupling of the motor and compressor stage, the complete electric motor output is transferred to the compressor stage, thus ensuring maximum efficiency.
- ▶ Equipped with a star delta switch as factory standard
- ▶ With the EasyTRONIC MICRO II electronic control unit featuring pressure sensor control as a factory standard – prevents motor overload, reduces wear and prolongs service life
- ▶ Excellent cooling performance and low noise thanks to thermostatically controlled radial fan
- ▶ Includes operating hours counter for logging load and post-run times; this ensures compliance with maintenance intervals – displays an automatic message to indicate that maintenance is due
- ▶ With sense of direction checking for the motor as a factory standard, thus avoiding possible damage during commissioning or after a change of location
- ▶ Easy maintenance due to easily accessible elements



A-PLUS 8-08

- ▶ Service-friendly thanks to optimum accessibility and easy removal and installation of all critical components



A-PLUS 8-08-270

Type	Maximum pressure bar	Effective delivery volume l/min	Motor output		Noise in dB(A)*	Dimensions (LxWxH) mm	Connection G	Vessel capacity l	Weight kg	Art. no.
			kW	PS						
A-PLUS model range - Screw-type compressors with ribbed belt drive (floor-mounted)**										
A-PLUS 8-08 (IE3)	8	1 250	7.5	10	68	800 x 700 x 980	3/4"	–	185	2092202
A-PLUS 8-10 (IE3)	10	1 000	7.5	10	68	800 x 700 x 980	3/4"	–	185	2092204
A-PLUS 8-13 (IE3)	13	750	7.5	10	68	800 x 700 x 980	3/4"	–	185	2092206
A-PLUS 11-08 (IE3)	8	1 650	11	15	69	800 x 700 x 980	3/4"	–	200	2092402
A-PLUS 11-10 (IE3)	10	1 500	11	15	69	800 x 700 x 980	3/4"	–	200	2092404
A-PLUS 11-13 (IE3)	13	1 100	11	15	69	800 x 700 x 980	3/4"	–	200	2092406
A-PLUS 15-08 (IE3)	8	2 150	15	20	70	800 x 700 x 980	3/4"	–	235	2092602
A-PLUS 15-10 (IE3)	10	1 850	15	20	70	800 x 700 x 980	3/4"	–	235	2092604
A-PLUS 15-13 (IE3)	13	1 500	15	20	70	800 x 700 x 980	3/4"	–	235	2092606
A-PLUS 16-08 (IE3)	8	2 350	15	20	68	800 x 700 x 980	3/4"	–	240	2092802
A-PLUS 16-10 (IE3)	10	2 050	15	20	68	800 x 700 x 980	3/4"	–	240	2092804
A-PLUS 16-13 (IE3)	13	1 750	15	20	68	800 x 700 x 980	3/4"	–	240	2092806

A-PLUS model range - Screw-type compressors with ribbed belt drive on vessel

A-PLUS 8-08-270 (IE3)	8	1 250	7.5	10	68	1 550 x 700 x 1 510	3/4"	270	245	2092222
A-PLUS 8-10-270 (IE3)	10	1 000	7.5	10	68	1 550 x 700 x 1 510	3/4"	270	245	2092224
A-PLUS 8-13-270 (IE3)	13	750	7.5	10	68	1 550 x 700 x 1 510	3/4"	270	245	2092226
A-PLUS 11-08-270 (IE3)	8	1 650	11	15	69	1 550 x 700 x 1 510	3/4"	270	260	2092422
A-PLUS 11-10-270 (IE3)	10	1 500	11	15	69	1 550 x 700 x 1 510	3/4"	270	260	2092424
A-PLUS 11-13-270 (IE3)	13	750	11	15	69	1 550 x 700 x 1 510	3/4"	270	260	2092426
A-PLUS 8-08-500 (IE3)	8	1 250	7.5	10	68	1 980 x 700 x 1 630	3/4"	500	307	2092232
A-PLUS 8-10-500 (IE3)	10	1 000	7.5	10	68	1 980 x 700 x 1 630	3/4"	500	307	2092234
A-PLUS 8-13-500 (IE3)	13	750	7.5	10	68	1 980 x 700 x 1 630	3/4"	500	307	2092236
A-PLUS 11-08-500 (IE3)	8	1 650	11	15	69	1 980 x 700 x 1 630	3/4"	500	322	2092432
A-PLUS 11-10-500 (IE3)	10	1 500	11	15	69	1 980 x 700 x 1 630	3/4"	500	322	2092434
A-PLUS 11-13-500 (IE3)	13	1 100	11	15	69	1 980 x 700 x 1 630	3/4"	500	322	2092436
A-PLUS 15-08-500 (IE3)	8	2 150	15	20	70	1 980 x 700 x 1 630	3/4"	500	357	2092632
A-PLUS 15-10-500 (IE3)	10	1 850	15	20	70	1 980 x 700 x 1 630	3/4"	500	357	2092634
A-PLUS 15-13-500 (IE3)	13	1 500	15	20	70	1 980 x 700 x 1 630	3/4"	500	357	2092636
A-PLUS 16-08-500 (IE3)	8	2 350	15	20	68	1 980 x 700 x 1 630	3/4"	500	362	2092832
A-PLUS 16-10-500 (IE3)	10	2 050	15	20	68	1 980 x 700 x 1 630	3/4"	500	362	2092834
A-PLUS 16-13-500 (IE3)	13	1 750	15	20	68	1 980 x 700 x 1 630	3/4"	500	362	2092836



- ▶ Optimum operating temperatures thanks to thermostatically controlled fan, optimum cooling air guidance and generously dimensioned heat exchangers, thus ensuring a longer service life and less oil temperature fluctuation than with thermostat control

- ▶ Factory standard re-cooler reduces overhead for drying and filtration of the generated compressed air
- ▶ Small footprint facilitates transport and deployment



- All oil lines are rubber hoses with steel mesh armoring
- This ensures maximum safety, even at high temperatures



- Excellent cooling performance and low noise thanks to thermostatically controlled radial fan



- Oil filter and oil microfilter separator cartridge are bolted on elements and easily accessible through the front panel



A-PLUS 16-10-500 K

Type	Maximum pressure	Effective delivery volume	Motor output		Noise	Dimensions (LxWxH)	Connection	Vessel capacity	Weight	Art. no.
	bar		l/min	kW						
Model range A-PLUS K - Screw-type compressors with ribbed belt drive on vessel with built-on refrigeration dryer										
A-PLUS 8-08-270 K (IE3)	8	1 250	7.5	10	68	1 550 x 700 x 1 510	3/4"	270	343	2092262
A-PLUS 8-10-270 K (IE3)	10	1 000	7.5	10	68	1 550 x 700 x 1 510	3/4"	270	343	2092264
A-PLUS 8-13-270 K (IE3)	13	750	7.5	10	68	1 550 x 700 x 1 510	3/4"	270	343	2092266
A-PLUS 11-08-270 K (IE3)	8	1 650	11	15	69	1 550 x 700 x 1 510	3/4"	270	363	2092462
A-PLUS 11-10-270 K (IE3)	10	1 500	11	15	69	1 550 x 700 x 1 510	3/4"	270	363	2092464
A-PLUS 11-13-270 K (IE3)	13	1 100	11	15	69	1 550 x 700 x 1 510	3/4"	270	363	2092466
A-PLUS 8-08-500 K (IE3)	8	1 250	7.5	10	68	1 980 x 700 x 1 630	3/4"	500	375	2092272
A-PLUS 8-10-500 K (IE3)	10	1 000	7.5	10	68	1 980 x 700 x 1 630	3/4"	500	375	2092274
A-PLUS 8-13-500 K (IE3)	13	750	7.5	10	68	1 980 x 700 x 1 630	3/4"	500	375	2092276
A-PLUS 11-08-500 K (IE3)	8	1 650	11	15	69	1 980 x 700 x 1 630	3/4"	500	395	2092472
A-PLUS 11-10-500 K (IE3)	10	1 500	11	15	69	1 980 x 700 x 1 630	3/4"	500	395	2092474
A-PLUS 11-13-500 K (IE3)	13	1 100	11	15	69	1 980 x 700 x 1 630	3/4"	500	395	2092476
A-PLUS 15-08-500 K (IE3)	8	2 150	15	20	70	1 980 x 700 x 1 630	3/4"	500	436	2092672
A-PLUS 15-10-500 K (IE3)	10	1 850	15	20	70	1 980 x 700 x 1 630	3/4"	500	436	2092674
A-PLUS 15-13-500 K (IE3)	13	1 500	15	20	70	1 980 x 700 x 1 630	3/4"	500	436	2092676
A-PLUS 16-08-500 K (IE3)	8	2 350	15	20	68	1 980 x 700 x 1 630	3/4"	500	436	2092872
A-PLUS 16-10-500 K (IE3)	10	2 050	15	20	68	1 980 x 700 x 1 630	3/4"	500	436	2092874
A-PLUS 16-13-500 K (IE3)	13	1 750	15	20	68	1 980 x 700 x 1 630	3/4"	500	436	2092876

*Sound pressure level at a distance of 1 m as per DIN 45635 T 13

A-PLUS Series - Screw-type compressors with ribbed belt drive for permanent operation at 100 % load.

- ▶ Noise-insulated screw-type compressor with ribbed belt drive (Poly V with high wear resistance) and slide clamping system
- ▶ The focus in this compressor's design was on energy efficiency, low maintenance costs, ease of installation and user-friendliness
- ▶ Equipped with EasyTRONIC IV electronic control incl. pressure sensor operation as a factory standard, thus avoiding motor overload, reducing wear and extended the service life
- ▶ Post-run timer control via control unit for individual accommodation of actual operating situation
- ▶ Equipped with a star delta circuitry as factory standard
- ▶ With sense of direction checking for the motor as a factory standard, thus avoiding possible damage during commissioning or after a change of location
- ▶ Monitoring of the operating pressure by means of a pressure sensor guarantees reliable, long-term stability in operations - the pressure sensor supports changes to the operating pressure directly via the control electronics without any mechanical intervention
- ▶ Includes operating hours counter for logging load and post-run times; this ensures compliance with maintenance intervals - displays an automatic message to indicate that maintenance is due
- ▶ Factory standard re-cooler reduces overhead for drying and filtering the compressed air generated
- ▶ Easy to maintain due to optimum accessibility of all components
- ▶ Simple removal and installation of all components that require regular maintenance
- ▶ The low noise level and the device's compact design, support deployment in a wide variety of working environments
- ▶ Easy transportation and ease of installation due to standard pallet-sized dimensions - footprint of less than 1 m²



A-PLUS 22-10

- ▶ Service-friendly thanks to optimum accessibility and easy removal and installation of all critical components

Type	Maximum pressure	Effective delivery volume	Motor output		Noise	Dimensions (LxWxH)	Connection	Vessel capacity	Weight	Art. no.
	bar		l/min	kW	PS					
A-PLUS model range - Screw-type compressors with ribbed belt drive (floor-mounted)										
A-PLUS 18.5-08 (IE3)	8	2 800	18.5	25	66	1 350 x 800 x 1 130	1"	–	350	2093202
A-PLUS 18.5-10 (IE3)	10	2 500	18.5	25	66	1 350 x 800 x 1 130	1"	–	350	2093204
A-PLUS 18.5-13 (IE3)	13	2 150	18.5	25	66	1 350 x 800 x 1 130	1"	–	350	2093206
A-PLUS 22-08 (IE3)	8	3 350	22	30	68	1 350 x 800 x 1 130	1"	–	380	2093402
A-PLUS 22-10 (IE3)	10	3 000	22	30	68	1 350 x 800 x 1 130	1"	–	380	2093404
A-PLUS 22-13 (IE3)	13	2 400	22	30	68	1 350 x 800 x 1 130	1"	–	380	2093406
A-PLUS-K model range - Screw-type compressor with ribbed belt drive (floor-mounted with refrigeration dryer)										
A-PLUS 18.5-08 K (IE3)	8	2 800	18.5	25	66	1 690 x 800 x 1 130	1"	–	400	2093242
A-PLUS 18.5-10 K (IE3)	10	2 500	18.5	25	66	1 690 x 800 x 1 130	1"	–	400	2093244
A-PLUS 18.5-13 K (IE3)	13	2 150	18.5	25	66	1 690 x 800 x 1 130	1"	–	400	2093246
A-PLUS 22-08 K (IE3)	8	3 350	22	30	68	1 690 x 800 x 1 130	1"	–	430	2093442
A-PLUS 22-10 K (IE3)	10	3 000	22	30	68	1 690 x 800 x 1 130	1"	–	430	2093444
A-PLUS 22-13 K (IE3)	13	2 400	22	30	68	1 690 x 800 x 1 130	1"	–	430	2093446

*Sound pressure level at 1 m distance as per DIN 45635 T 13



A-PLUS 18.5-10 K



- Flexible oil line
- Maximum safety, even at high temperatures



- Excellent cooling performance and low noise thanks to thermostatically controlled radial fan

Energy savings thanks to frequency controlled air compressors

SpeedTronic control

Reducing energy consumption and conserving precious energy resources is a global challenge considering its impact on the environment. The A-PLUS series, with outputs of 22, 37, 55 and 75 kW, is also available in speed controlled version, providing high performance combined

with energy saving solutions. You can make significant energy savings using variable speed compressors in a typical installation.

A frequency converter dynamically adjusts the voltage, frequency and amperage values of the motor. The air output is constantly adjusted between 50 and 100 percent of the compressor full capacity. This leads to the following, measurable positive effects:

- ▶ Precision coverage of air requirements thanks to continuous control of the motor speed and compressed air generation
- ▶ Minimises unnecessary energy losses through continuous adaptation of compressed air output to the actual air requirement
- ▶ Energy consumption proportional to the delivered compressed air
- ▶ Constant and accurate pressure control selectable at any value between 6 and 10 bar (13 bar on demand).

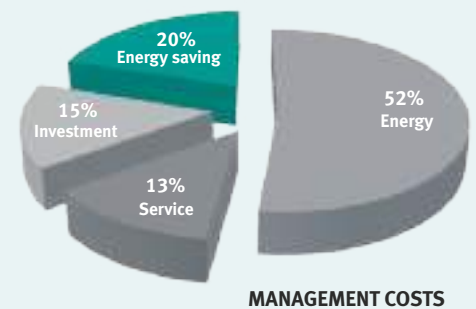
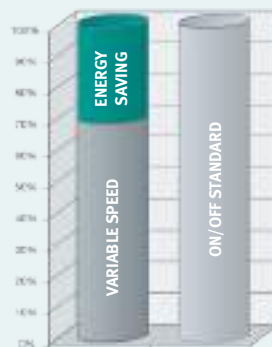

Type	Maximum pressure bar	Effective delivery volume l/min	Motor output		Noise in dB(A)*	Dimensions (LxWxH) mm	Connection G	Vessel capacity l	Weight kg	Art. no.
			kW	PS						
A-PLUS VS model range - Screw-type compressor with ribbed belt drive (floor-mounted with frequency control)										
A-PLUS 22-08 VS (IE3)	8	3 350 / 1 350	22	30	68	1 350 x 800 x 1 130	1"	–	390	2093502
A-PLUS 22-10 VS (IE3)	10	3 050 / 1 220	22	30	68	1 350 x 800 x 1 130	1"	–	390	2093504
A-PLUS VS K model range - Screw-type compressor with ribbed belt drive (floor-mounted with frequency control and add-on refrigeration dryer)										
A-PLUS 22-08 VS K (IE3)	8	3 350 / 1 350	22	30	68	1 690 x 800 x 1 130	1"	–	440	2093542
A-PLUS 22-10 VS K (IE3)	10	3 050 / 1 220	22	30	68	1 690 x 800 x 1 130	1"	–	440	2093544

*Sound pressure level at a distance of 1 m as per DIN 45635 T 13

A-PLUS Series - Noise-insulated screw-type compressors from 30 to 75 kW

- ▶ All main components of the air compressor are manufactured with the help of numerically controlled toolmaking machines, including the intake controller, separator block and minimum pressure valve.
- ▶ Cooling is via a temperature-controlled radial fan and a generously dimensioned combination cooler. This guarantees optimum cooling, even under the most extreme conditions of use.
- ▶ Large access panels allow for easy maintenance and immediate checking of the internal components, thus reducing the time required for inspection and maintenance to a minimum.
- ▶ The most important operating parameters are monitored by the electronic EasyTRONIC IV: in addition to a variety of functions, there is a week timer for switching on and off to meet all of the user's requirements. Additionally, up to four machines can be controlled simultaneously based on the master/slave principle.
- ▶ Equipped with a star delta circuitry as factory standard



A-PLUS 38-10



A-PLUS 45-10

Type	Maximum pressure bar	Effective delivery volume l/min	Motor output		Noise in dB(A)*	Dimensions (LxWxH) mm	Connection G	Weight kg	Art. no.
			kW	PS					
A-PLUS model range - Screw-type compressors with ribbed belt drive (floor-mounted)**									
A-PLUS 31-08 (IE3)	8	4 700	30	40	70	1 530 x 830 x 1 440	1 -1/4"	630	2093602
A-PLUS 31-10 (IE3)	10	4 200	30	40	70	1 530 x 830 x 1 440	1 -1/4"	630	2093604
A-PLUS 31-13 (IE3)	13	3 400	30	40	70	1 530 x 830 x 1 440	1 -1/4"	630	2093606
A-PLUS 38-08 (IE3)	8	6 000	37	50	68	1 530 x 830 x 1 440	1 -1/4"	700	2093802
A-PLUS 38-10 (IE3)	10	5 300	37	50	68	1 530 x 830 x 1 440	1 -1/4"	700	2093804
A-PLUS 38-13 (IE3)	13	4 000	37	50	68	1 530 x 830 x 1 440	1 -1/4"	700	2093806
A-PLUS 45-08 (IE3)	7.5	7 200	45	60	72	1 600 x 970 x 1 860	1 -1/2"	910	2094202
A-PLUS 45-10 (IE3)	10	6 500	45	60	72	1 600 x 970 x 1 860	1 -1/2"	910	2094204
A-PLUS 45-13 (IE3)	13	5 100	45	60	72	1 600 x 970 x 1 860	1 -1/2"	910	2094206
A-PLUS 55-08 (IE3)	7.5	8 600	55	75	74	1 600 x 970 x 1 860	1 -1/2"	952	2094402
A-PLUS 55-10 (IE3)	10	7 800	55	75	74	1 600 x 970 x 1 860	1 -1/2"	952	2094404
A-PLUS 55-13 (IE3)	13	6 400	55	75	74	1 600 x 970 x 1 860	1 -1/2"	952	2094406
A-PLUS 56-08 (IE3)	7.5	9 300	55	75	70	1 800 x 1 100 x 2 150	2"	1650	2094602
A-PLUS 56-10 (IE3)	10	8 300	55	75	70	1 800 x 1 100 x 2 150	2"	1650	2094604
A-PLUS 56-13 (IE3)	13	7 000	55	75	70	1 800 x 1 100 x 2 150	2"	1650	2094606
A-PLUS 75-08 (IE3)	7.5	12 200	75	100	72	1 800 x 1 100 x 2 150	2"	1720	2094802
A-PLUS 75-10 (IE3)	10	10 500	75	100	72	1 800 x 1 100 x 2 150	2"	1720	2094804
A-PLUS 75-13 (IE3)	13	8 300	75	100	72	1 800 x 1 100 x 2 150	2"	1720	2094806

*Sound pressure level at a distance of 1 m as per DIN 45635 T 13



A-PLUS 75-10 VS



Minimum pressure valve

- Made of oxidation-resistant material
- Great care in manufacturing ensures reliable operation even under the most extreme conditions.



Pre-filter panel

- The cell is equipped with a pre-filter panel that keeps back the dust and ensures that the interior of the machine stays clean.



Energy savings thanks to frequency controlled air compressors

Reducing energy consumption and conserving precious energy resources is a global challenge considering its impact on the environment. The A-PLUS series, with outputs of 22, 37, 55 and 75 kW, is also available in speed controlled version, providing high performance combined

with energy saving solutions. You can make significant energy savings using variable speed compressors in a typical installation.

Type	Maximum pressure bar	Effective delivery volume l/min	Motor output		Noise in dB(A)*	Dimensions (LxWxH) mm	Connection G	Weight kg	Art. no.
			kW	PS					
A-PLUS-K model range - Screw-type compressor with ribbed belt drive (floor-mounted with refrigeration dryer)									
A-PLUS 31-08 K (IE3)	8	4 700	30	40	70	1 530 x 830 x 1 440	1 -1/4"	710	2093642
A-PLUS 31-10 K (IE3)	10	4 200	30	40	70	1 530 x 830 x 1 440	1 -1/4"	710	2093644
A-PLUS 31-13 K (IE3)	13	3 400	30	40	70	1 530 x 830 x 1 440	1 -1/4"	710	2093646
A-PLUS 38-08 K (IE3)	8	6 000	37	50	68	1 860 x 830 x 1 440	1 -1/4"	780	2093842
A-PLUS 38-10 K (IE3)	10	5 300	37	50	68	1 860 x 830 x 1 440	1 -1/4"	780	2093844
A-PLUS 38-13 K (IE3)	13	4 000	37	50	68	1 860 x 830 x 1 440	1 -1/4"	780	2093846
A-PLUS VS model range - Screw-type compressor with ribbed belt drive (floor-mounted with frequency control)									
A-PLUS 38-08 VS (IE3)	8	5 900 / 2 350	37	50	72	1 530 x 830 x 1 440	1 -1/4"	725	2093902
A-PLUS 38-10 VS (IE3)	10	5 200 / 2 050	37	50	72	1 530 x 830 x 1 440	1 -1/4"	725	2093904
A-PLUS 56-08 VS (IE3)	7.5	9 300 / 3 700	55	75	70	1 800 x 1 100 x 2 150	2"	1686	2094702
A-PLUS 56-10 VS (IE3)	10	8 300 / 3 300	55	75	70	1 800 x 1 100 x 2 150	2"	1686	2094704
A-PLUS 75-08 VS (IE3)	7.5	12 200 / 48.00	75	100	72	1 800 x 1 100 x 2 150	2"	1756	2094902
A-PLUS 75-10 VS (IE3)	10	10 500 / 4 200	75	100	72	1 800 x 1 100 x 2 150	2"	1756	2094904
A-PLUS VS model range - Screw-type compressor with ribbed belt drive (floor-mounted with frequency control and add-on refrigeration dryer)									
A-PLUS38-08 K VS (IE3)	8	5 900 / 2 350	37	50	72	1 860 x 830 x 1 440	1 -1/4"	805	2093942
A-PLUS38-10 K VS (IE3)	10	5 200 / 2 050	37	50	72	1 860 x 830 x 1 440	1 -1/4"	805	2093944

*Sound pressure level at a distance of 1 m as per DIN 45635 T 13

Long Life Kit for screw compressors scheduled maintenance

- ▶ **FSN original spare parts** have been rigorously selected, checked and tested by specialized technicians to ensure the utmost efficiency and endurance of the compressor.
- ▶ Specialized staff is continuously in contact with our distribution centres worldwide, to deliver spare parts to our customers in the least time possible.
- ▶ The use of **FSN Long Life Kit**, specifically studied for screw compressors, extends maintenance intervals, cutting down service costs and ensuring consistent product performance, with consequential energy saving.
- ▶ Warranty claims can only be accepted if you use original parts.



Regular maintenance A-MICRO series

		1 000 h * (or every year)	2 000 h * (or every year)	4 000 h	6 000 h	8 000 h	12 000 h
		· 1 Air filter cartridge	· 1 Air filter cartridges · 1 Oil filter cartridge · 1 Separator cartridge	· 1 x 2 000 hrs kit · 1 Oil check valve	· 1 x 2 000 hrs kit · 1 Poly V belt	· 1 x 4 000 hrs kit · 1 minimum pressure valve kit	· 1 x 4 000 hrs kit · 1 Poly V belt · 1 Solenoid valve
2.2 - 5.5 kW	Commodity group	1 000 h (or every year)	KIT A	KIT B	KIT C	KIT D	KIT E
A-MICRO SE 2.2-10 M	285	0017092000N	0260KTA00E	0260KTB00E	0260KTC00E	0260KTD00E	0260KTE00E
A-MICRO SE 2.2-08	285				0260KTC01E		0260KTE01E
A-MICRO SE 2.2-10	285				0260KTC02E		0260KTE02E
A-MICRO SE 3.0-08	285				0260KTC03E		0260KTE03E
A-MICRO SE 3.0-10	285				0260KTC04E		0260KTE04E
A-MICRO SE 4.0-08	285				0260KTC05E		0260KTE05E
A-MICRO SE 4.0-10	285				0260KTC04E		0260KTE27E
A-MICRO 4.0-08	285				0260KTC05E		0260KTE28E
A-MICRO 4.0-10	285				0260KTC03E		0260KTE29E
A-MICRO 4.0-13	285				0260KTC04E		0260KTE27E
A-MICRO 5.5-08	285				0260KTC05E		0260KTE28E
A-MICRO 5.5-10	285						0260KTE29E
A-MICRO 5.5-13	285						

Designation	Art. no.
Air filter cartridge	0017092000N
LLK-A 2.2-5.5 MMGD	0260KTA00E
LLK-B 2.2-5.5 MMGD	0260KTB00E
LLK-C 2.2 MMGD 10B	0260KTC00E
LLK-C 2.2 MMGD 8B	0260KTC01E
LLK-C 2.2 MMGD 10B	0260KTC02E
LLK-C 3-4 MMGD 8-13B	0260KTC03E
LLK-C 4-5.5 MMGD 8-10B	0260KTC04E
LLK-C 4-5.5 MMGD 8-10B	0260KTC05E
LLK-D 2.2-5.5 MMGD	0260KTD00E

Designation	Art. no.
LLK-E 2.2M MMGD 10B	0260KTE00E
LLK-E 2.2 MMGD 8B	0260KTE01E
LLK-E 2.2 MMGD 10B	0260KTE02E
LLK-E 3 MMGD	0260KTE03E
LLK-E 4 MMGD 8B	0260KTE04E
LLK-E 4 MMGD 10B	0260KTE05E
LLK-E 4-5.5 MMGD	0260KTE27E
LLK-E 4-5.5 MMGD	0260KTE28E
LLK-E 4-5.5 MMGD	0260KTE29E

Individual components A-MICRO series

		4 000 h	6 000 h	8 000 h	12 000 h	16 000 h	
		· Oil check valve	· Intake regulator kit	· Poly V belt	· Minimum pressure valve kit	· Solenoid valve	· Air-end
2.2 - 5.5 kW	Commodity group	4 000 h	6 000 h	8 000 h	12 000 h	16 000 h	
A-MICRO SE 2.2-10 M	285	047060000	0451J00041	045197000	008436000	05305100110	
A-MICRO SE 2.2-08	285			045188000			
A-MICRO SE 2.2-10	285			045183000			
A-MICRO SE 3.0-08	285			045181000			
A-MICRO SE 3.0-10	285			045182000			
A-MICRO SE 4.0-08	285			045180000			
A-MICRO SE 4.0-10	285		045182000	347111000			
A-MICRO SE 4.0-10	285		045180000				
A-MICRO 4.0-08	285		045181000				
A-MICRO 4.0-10	285		045182000				
A-MICRO 4.0-13	285		045180000				
A-MICRO 5.5-08	285		045181000				
A-MICRO 5.5-10	285		045182000	008223000			
A-MICRO 5.5-13	285	045180000					

Designation	Art. no.
Oil check valve	0047060000
Intake regulator kit	0451J00041
Intake regulator kit	0260249051
Poly V belt	045197000
Poly V belt	045188000
Poly V belt	045183000
Poly V belt	045181000

Designation	Art. no.
Poly V belt	045182000
Poly V belt	045180000
Minimum pressure valve kit	347111000
Solenoid valve	008436000
Solenoid valve	008223000
Compressor	05305100110

* We recommend changing the oil at the indicated interval or every year. We recommend use of our RotEnergyA-PLUS oil (NOT INCLUDED IN THE LONG LIFE KIT).



Regular maintenance A-PLUS series

		1 000 h * (or every year)	2 000 h * (or every year)	4 000 h	8 000 h	12 000 h
		· 1 Air filter cartridge	· 1 Air filter cartridges · 1 Oil filter cartridge · 1 Separator cartridge	· 1 x 2 000 hrs kit · 1 Oil check valve	· 1 x 4 000 hrs kit · 1 minimum pressure valve kit · 1 Poly V belt	· 1 x 4 000 hrs kit · 1 Solenoid valve
7.5 - 15 kW	Commodity group	1 000 h (or every year)	KIT A	KIT B	KIT D	KIT E
A-PLUS 8-08	285	0017092000N	0260KTA01E	0260KTB01E	0260KTD01E	0260KTE07E
A-PLUS 8-10	285				0260KTD02E	
A-PLUS 8-13	285				0260KTD01E	
A-PLUS 11-08	285	0017093000N	0260KTA02E	0260KTB02E	0260KTD03E	0260KTE08E
A-PLUS 11-10	285				0260KTD04E	
A-PLUS 11-13	285					
A-PLUS 15-08	285				0260KTD03E	
A-PLUS 15-10	285					
A-PLUS 15-13	285					
A-PLUS 16-08	285				0260KTD04E	
A-PLUS 16-10	285					
A-PLUS 16-13	285					

Designation	Art. no.	Designation	Art. no.
Air filter cartridge	0017092000N	LLK-D 8 PSSD 8-13B	0260KTD01E
Air filter cartridge	0017093000N	LLK-D 8 PSSD 10B	0260KTD02E
LLK-A 8 PSSD	0260KTA01E	LLK-D 11-15 PSSD 8-10B	0260KTD03E
LLK-A 11-16 PSSD	0260KTA02E	LLK-D 11-16 PSSD	0260KTD04E
LLK-B 8 PSSD	0260KTB01E	LLK-E 8 PSSD	0260KTE07E
LLK-B 11-16 PSSD	0260KTB02E	LLK-E 11-16 PSSD	0260KTE08E

Individual components A-PLUS series

		4 000 h		6 000 h	8 000 h	12 000 h	16 000 h
		· Oil check valve	· Intake regulator kit	· Poly V belt	· Minimum pressure valve kit	· Solenoid valve	· Air-end
7.5 - 15 kW	Commodity group	4 000 h		6 000 h	8 000 h	12 000 h	16 000 h
A-PLUS 8-08	285	0012096000	0260249050	045122000	0347111000	0008195010	05303000110
A-PLUS 8-10	285			045171000			
A-PLUS 8-13	285			045122000			
A-PLUS 11-08	285		045121000				
A-PLUS 11-10	285		045122000				
A-PLUS 11-13	285		045171000				
A-PLUS 15-08	285	0260264050		045121000			
A-PLUS 15-10	285						
A-PLUS 15-13	285						
A-PLUS 16-08	285						
A-PLUS 16-10	285			045122000			05304000110
A-PLUS 16-13	285						

Designation	Art. no.	Designation	Art. no.
Oil check valve	0012096000	Poly V belt	045121000
Intake regulator kit	0260249050	Minimum pressure valve kit	0347111000
Poly V belt	0260264050	Solenoid valve	0008195010
Poly V belt	045122000	Compressor	05303000110
Poly V belt	045171000	Compressor	05304000110

* We recommend changing the oil at the indicated interval or every year. We recommend use of our RotEnergyA-PLUS oil (NOT INCLUDED IN THE LONG LIFE KIT).



Regular maintenance A-PLUS series 18.5 - 75 kW

	2 000 h * (or every year)	4 000 h * (or every year)	8 000 h	12 000 h
	· 1 Air filter cartridge	· 1 Air filter cartridge · 1 Oil filter cartridge · 1 Separator cartridge ≤ 45 kW · 2 Separator cartridges ≥ 55 kW · 1 Oil check valve ≤ 45 kW · 2 Oil check valves ≥ 55 kW	· 1 x 4 000 hrs kit · 1 Minimum pressure valve kit	· 1 x 4 000 hrs kit · 1 Solenoid valve · 1 Poly V belt

18.5 - 75 kW	Commodity group	2 000 h * (or every year)	KIT B	KIT D	KIT E
A-PLUS 18,5-08	285	0017101000	0260KTB03E	0260KTD07E	0260KTE09E
A-PLUS 18,5-10	285				0260KTE10E
A-PLUS 18,5-13	285				0260KTE09E
A-PLUS 22-08	285				0260KTE20E
A-PLUS 22-10	285				0260KTE21E
A-PLUS 22-13	285		0260KTB04E	0260KTD08E	0260KTE11E
A-PLUS 22-08 VS	285				0260KTE12E
A-PLUS 22-10 VS	285				0260KTE11E
A-PLUS 31-08	285				0260KTE13E
A-PLUS 31-10	285				0260KTE22E
A-PLUS 31-13	285	0017083000	0260KTB05E	0260KTD09E	0260KTE14E
A-PLUS 38-08	285				0260KTE23E
A-PLUS 38-10	285				0260KTE15E
A-PLUS 38-13	285				0260KTE16E
A-PLUS 45-08	285				0260KTE17E
A-PLUS 45-10	285		0260KTB06E	0260KTD10E	0260KTE18E
A-PLUS 45-13	285				0260KTE17E
A-PLUS 55-08	285				0260KTE24E
A-PLUS 55-10	285				0260KTE23E
A-PLUS 55-13	285				0260KTE15E
A-PLUS 55-08 VS	285	0017067001	0260KTB11E	0260KTD16E	0260KTE15E
A-PLUS 55-10 VS	285				0260KTE16E
A-PLUS 56-08	285				0260KTE17E
A-PLUS 56-10	285				0260KTE18E
A-PLUS 56-13	285				0260KTE17E
A-PLUS 75-10	285		0260KTB08E	0260KTD11E	0260KTE24E
A-PLUS 75-08	285				0260KTE17E
A-PLUS 75-13	285				0260KTE18E
A-PLUS 75-08 VS	285				0260KTE17E
A-PLUS 75-10 VS	285				0260KTE17E

Designation	Art. no.
Air filter cartridge 18.5 – 22 kW	0017101000
Air filter cartridge 31 – 55 kW	0017083000
Air filter cartridge 55 – 75 kW	0017067001
LLK-B 18.5-22 PSSD	0260KTB03E
LLK-B 31-38 PSSD	0260KTB04E
LLK-B 45 PS	0260KTB05E
LLK-B 55 PS	0260KTB06E
LLK-B 75 PS	0260KTB07E
LLK-B 56 PS	0260KTB08E
LLK-B 22 VS PSSD	0260KTB09E
LLK-B 38 VS PSSD	0260KTB10E
LLK-B 56 VS PS	0260KTB11E
LLK-B 75 VS PS	0260KTB12E
LLK-D 18.5-22 PSSD	0260KTD07E
LLK-D 31-38 PSSD	0260KTD08E
LLK-D 45 PS	0260KTD09E
LLK-D 55 PS	0260KTD10E
LLK-D 56 PS	0260KTD11E
LLK-D 75 PS	0260KTD12E

Designation	Art. no.
LLK-D 22 VS PSSD	0260KTD14E
LLK-D 38 VS PSSD	0260KTD15E
LLK-D 56 VS PS	0260KTD16E
LLK-D 75 VS PS	0260KTD17E
LLK-E 18.5-22 PSSD 13B	0260KTE09E
LLK-E 22 PSSD 8-10B	0260KTE10E
LLK-E 31-38 PSSD 8-13B	0260KTE11E
LLK-E 38 PSSD 10B	0260KTE12E
LLK-E 45 PS 8-10B	0260KTE13E
LLK-E 55 PS	0260KTE14E
LLK-E 56 PS 8-10B	0260KTE15E
LLK-E 56 PS 13B	0260KTE16E
LLK-E 75 PS 8-13B	0260KTE17E
LLK-E 75 PS 10B	0260KTE18E
LLK-E 22 VS PSSD	0260KTE20E
LLK-E 38 VS PSSD	0260KTE21E
LLK-E 45 PS 13B	0260KTE22E
LLK-E 56 VS PS	0260KTE23E
LLK-E 75 VS PS	0260KTE24E

* We recommend changing the oil at the indicated interval or every year. We recommend use of our RotEnergyA-PLUS oil (NOT INCLUDED IN THE LONG LIFE KIT).





Individual components A-PLUS series 18.5 - 75 kW

		4 000 h		8 000 h		12 000 h		20 000 h	24 000 h
		· Oil check valve	· Prefilter	· Prefilter for switch cabinet	· Intake regulator kit	· Minimum pressure valve kit	· Poly V belt	· Solenoid valve	· Air-end
18.5 - 75 kW	Commodity group	4 000 h		8 000 h		12 000 h		20 000 h	24 000 h
A-PLUS 18,5-08	285	0012096000	0160QQ0094	not available	260264050	0045111000	0008195010	05304000100	not available
A-PLUS 18,5-10	285								
A-PLUS 18,5-13	285								
A-PLUS 22-08	285								
A-PLUS 22-10	285								
A-PLUS 22-13	285								
A-PLUS 22-08 VS	285								
A-PLUS 22-10 VS	285								
A-PLUS 31-08 VS	285								
A-PLUS 31-10 VS	285								
A-PLUS 31-08	285								
A-PLUS 31-10	285								
A-PLUS 31-13	285								
A-PLUS 38-08	285								
A-PLUS 38-10	285								
A-PLUS 38-13	285								
A-PLUS 45-08	285								
A-PLUS 45-10	285								
A-PLUS 45-13	285								
A-PLUS 55-08	285								
A-PLUS 55-10	285								
A-PLUS 55-13	285								
A-PLUS 55-08 VS	285								
A-PLUS 55-10 VS	285								
A-PLUS 56-08	285								
A-PLUS 56-10	285								
A-PLUS 56-13	285								
A-PLUS 75-10	285								
A-PLUS 75-08	285								
A-PLUS 75-13	285								
A-PLUS 75-08 VS	285								
A-PLUS 75-10 VS	285								
		2 x 0012096000	0160BE0013	not available	419265010	0045202000	0008465000	05307200000	
				0160BE0024		0045191000		not available	
				0160BE0024		0045189000		not available	
				0160BE0024		0045203000		not available	
				0160BE0024		0045203000		not available	
				0160BE0024		0045203000		not available	
				0160BE0024		0045203000		not available	
				0160BE0024		0045191000		not available	

Designation	Art. no.	Designation	Art. no.
Air filter cartridge	0012096000	Poly V belt	0045132000
Air filter cartridge	2 x 0012096000	Poly V belt	0045117000
Pre-Filter	0160QQ0094	Poly V belt	0045132000
Pre-Filter	0160TV0035	Poly V belt	0045219000
Pre-Filter	0160NS0023	Poly V belt	0045118000
Pre-Filter	0160BE0013	Poly V belt	0045189000
Prefilter for switch cabinet	0160SY0055	Poly V belt	0045203000
Prefilter for switch cabinet	0160TW0056	Poly V belt	0045202000
Prefilter for switch cabinet	0160BE0024	Poly V belt	0045191000
Intake regulator kit	0260264050	Solenoid valve	0008195010
Intake regulator kit	0419253010	Solenoid valve	0008465000
Intake regulator kit	0419265010	Compressor	05304000110
Minimum pressure valve kit	0247150000	Compressor	05307100010
Minimum pressure valve kit	0213500030	Compressor	05308000000
Poly V belt	0045111000	Compressor	05307100010
Poly V belt	0045217000	Compressor	05307200000

* We recommend changing the oil at the indicated interval or every year. We recommend use of our RotEnergyA-PLUS oil (NOT INCLUDED IN THE LONG LIFE KIT).



Piston compressors
 Screw-type compressors
 System components
 Compressed air maintenance units
 Compressed air distribution
 Tools

Long Life Kits



Not suitable for IE 3 models!

A-MICRO



Commodity group		1 000 h	2 000 h ** (or every year)	6 000 h	8 000 h	16 000 h
		· 1 Air filter cartridge	· 2 Air filter cartridges · 1 Oil filter cartridge · 1 Separator cartridge · 1 Oil check valve	· 1 x 2 000 hrs kit · 1 Belt · 1 Intake regulator kit · 1 Solenoid valve	· 1 x 2 000 hrs kit · 1 Minimum pressure valve kit · 3 Pipes	· 1 x 8 000 hrs kit · 1 Air-end
A-MICRO 308 SE	285	0017092000N	0260KTA380	0260KTB383	0260KTC380	0260KTD380
A-MICRO 310 SE	285			0260KTB386		
A-MICRO 310 M	285			0260KTB389		
A-MICRO 408 SE	285			0260KTB392		
A-MICRO 410 SE	285			0260KTB395		
A-MICRO 508 SE	285			0260KTB398		
A-MICRO 510 SE	285			0260KTB401		
A-MICRO 508 TA	285			0260KTB405		
A-MICRO 510-713 TA	285			0260KTB407		
A-MICRO 513 TA	285					

** We recommend changing the oil at the indicated interval or every year.
We recommend use of our RotEnergyA-PLUS oil (NOT INCLUDED IN THE LONG LIFE KIT).

Designation	Art. no.	Designation	Art. no.
Air filter cartridge	0017092000N	LK 6000H MMGD 5(4) 10B	0260KTB398
LK 2000H MMGD 3-10(2.2-7.5)	0260KTA380	LK 6000H MMGD 5(4) 8B	0260KTB401
LK 6000H MMGD 3(2.2) 8 B	0260KTB383	LK 6000H MMGD 5(4) 10B	0260KTB405
LK 6000H MMGD 3(2.2) 10 B	0260KTB386	LK 6000H MMGD 5(4) 13B	0260KTB407
LK 6000H MMGD 3(2.2) 10 B MONO	0260KTB389	LK 8000H MMGD 3-5.5(2.2-4)	0260KTC380
LK 6000H MMGD 4(3.0) 8-10 B	0260KTB392	LK 16000H MMGD 3-5.5(2.2-4)	0260KTD380
LK 6000H MMGD 5(4.0) 8 B	0260KTB395		

A-CUBE SD



Commodity group		1 000 h	2 000 h ** (or every year)	4 000 h ** (annually)	12 000 h	24 000 h
		· 1 Air filter cartridge	· 2 Air filter cartridges · 1 Oil filter cartridge	· 1 x 2 000 hrs kit · 1 Separator cartridge · 1 Oil check valve · 1 Intake regulator kit	· 1 x 4 000 hrs kit · 1 Minimum pressure valve · 1 Solenoid valve · 1 Motor bearing · 3 Pipes	· 1 x 12 000 hrs kit · 1 Air-end
A-CUBE SD 5	285	0017092000N	0260KTA620	0260KTB620	0260KTC620	0260KTD620
A-CUBE SD 1010	285				0260KTC625	0260KTD625
A-CUBE SD 710	285				0260KTC620	0260KTD720
A-CUBE SD 713	285				0260KTC625	0260KTD725
A-CUBE SD 1013	285				0260KTC720	0260KTD820
A-CUBE 5 ES	285				0260KTC725	0260KTD825
A-CUBE SD 1010 ES	285				0260KTC720	0260KTD920
A-CUBE SD 710 ES	285				0260KTC725	0260KTD925
A-CUBE SD 713 ES	285					
A-CUBE SD 1013 ES	285					

** We recommend changing the oil at the indicated interval or every year.
We recommend use of our RotEnergyA-PLUS oil (NOT INCLUDED IN THE LONG LIFE KIT).

Designation	Art. no.	Designation	Art. no.
Air filter cartridge	0017092000N	LK 24000H CUBE10 (7.5)	0260KTD625
LK 2000H CUBE	0260KTA620	LK 24000H CUBE 7(5.5) 10-13 B	0260KTD720
LK 4000H CUBE	0260KTB620	LK 24000H CUBE 10(7.5) 13 B	0260KTD725
LK 12000H CUBE 5-7 (4-5.5)	0260KTC620	LK 24000H CUBE 5 (4.0)+ES	0260KTD820
LK 12000H CUBE 10 (7.5)	0260KTC625	LK 24000H CUBE 10(7.5)	0260KTD825
LK 12000H CUBE 5-7 (4-5.5)+ES	0260KTC720	LK 24000H CUBE 7(5.5) 10-13 B+ES	0260KTD920
LK 12000H CUBE 10 (7.5)+ES	0260KTC725	LK 24000H CUBE 10(7.5) 13 B+ES	0260KTD925
LK 24000H CUBE 5 (4.0)	0260KTD620		





Not suitable for IE 3 models!

A-QUADRO



Commodity group	1 000 h	4 000 h ** (or every year)	8 000 h	12 000 h	20 000 h
	· 1 Air filter cartridge	· 2 Air filter cartridges · 1 Oil filter cartridge · 1 Separator cartridge · 1 Oil check valve · 1 Intake regulator kit	· 1 x 4 000 hrs kit · 1 Minimum pressure valve · 4 Pipes	· 1 x 4 000 hrs kit · 1 Belt · 1 Solenoid valve	· 1 x 4 000 hrs kit · 1 Air-end
A-QUADRO 1008	285	0017092000N	0260KTA370	0260KTB370	0260KTC370
A-QUADRO 1013	285				
A-QUADRO 1010	285	0017093000N	0260KTA375	0260KTB375	0260KTD370
A-QUADRO 1510	285				
A-QUADRO 2013	285				
A-QUADRO 1513	285				
A-QUADRO 1508	285				
A-QUADRO 2008	285				
A-QUADRO 2010	285				
A-QUADRO 2108	285				
A-QUADRO 2110	285				
A-QUADRO 2113	285				

** We recommend changing the oil at the indicated interval or every year.
We recommend use of our RotEnergyA-PLUS oil (NOT INCLUDED IN THE LONG LIFE KIT).

Designation	Art. no.	Designation	Art. no.
Air filter cartridge	0017092000N	LK 12000H QPSSMSD 10(7.5)	0260KTC371
Air filter cartridge	0017093000N	LK 12000H QPSSMSD 15-20(11-15)	0260KTC375
LK 4000H QPSSMSD 10(7.5)	0260KTA370	LK 12000H QPSSMSD 15-21(11-16)	0260KTC376
LK 4000H QPSSMSD15-20-21(111516)	0260KTA375	LK 12000H QPSSMSD15-20(1115)8-10	0260KTC377
LK 8000H QPSSMSD 10(7.5)	0260KTB370	LK 20000H QPSSMSD 10(7.5)	0260KTD370
LK 8000H QPSSMSD15-20-21(111516)	0260KTB375	LK 20000H QPSSMSD 15-20(11-15)	0260KTD375
LK 12000H QPSSMSD 10(7.5) 8-13B	0260KTC370	LK 20000H QPSSMSD 21(16)	0260KTD376

A-BSC Revo



Commodity group	1 000 h	4 000 h ** (or every year)	12 000 h	24 000 h
	· 1 Air filter cartridge	· 2 Air filter cartridges · 1 Oil filter cartridge · 1 Separator cartridge · 1 Oil check valve · 1 Intake regulator kit	· 1 x 4 000 hrs kit · 1 Belt · 1 Minimum pressure valve kit · 1 Solenoid valve · 3 Pipes	· 1 x 12 000 hrs kit · 1 Air-end
A-BSC Revo 1508	285	0017093000N	0260KTA030	0260KTC138
A-BSC Revo 1510	285			0260KTD138
A-BSC Revo 1513	285			0260KTC130
A-BSC Revo 2008	285			0260KTD130
A-BSC Revo 2010	285			0260KTC133
A-BSC Revo 2013	285			0260KTD133
			0260KTC238	0260KTD238
			0260KTC230	0260KTD230
			0260KTC233	0260KTD233

** We recommend changing the oil at the indicated interval or every year.
We recommend use of our RotEnergyA-PLUS oil (NOT INCLUDED IN THE LONG LIFE KIT).

Designation	Art. no.	Designation	Art. no.
Air filter cartridge	0017093000N	LK 24000H BSC1510	0260KTD130
LK 4000H BSC 15-20	0260KTA030	LK 24000H BSC1513	0260KTD133
LK 12000H BSC1510	0260KTC130	LK 24000H BSC1508	0260KTD138
LK 12000H BSC1513	0260KTC133	LK 24000H BSC 2010	0260KTD230
LK 12000H BSC 1508	0260KTC138	LK 24000H BSC 2013	0260KTD233
LK 12000H BSC2010	0260KTC230	LKK 12000H BSC 2008	0260KTC238
LK 12000H BSC 2013	0260KTC233	LKK 24000H BSC 2008	0260KTD238



A-K-MAX 5.5 - 11 kW: new design, high performance.

- ▶ The Aircraft A-K-MAX model range is available in a variety of configurations that precisely meet the customer's requirements:
- ▶ Starting with the standard floor mounted version, the range can also be selected with a 270 or 500 litre air vessel, with or without refrigeration dryer, also available with inverter drive.
- ▶ The whole machine is extremely compact with balanced dimensions.

- ▶ **Direct drive technology for maximum reliability.**
- ▶ **High performances, excellent efficiency.**
- ▶ **Intelligent microprocessor control.**
- ▶ **Compact, space saving design**
- ▶ **Maintenance-free drive**
- ▶ **Energy saving**



A-K-Max 5.5

5.5 kW



A-K-Max 7.5

7.5 kW



A-K-Max 11

11 kW

Available versions:

- floor mounted compressor
- Compressor + vessel
- Compressor + vessel + refrigeration dryer

Available versions:

- floor mounted compressor
- Compressor + refrigeration dryer
- Compressor + vessel
- Compressor + vessel + refrigeration dryer

Available versions:

- floor mounted compressor
- Compressor + refrigeration dryer
- Compressor + vessel
- Compressor + vessel + refrigeration dryer

Air-end:

FSC 26



Air-end:

FSC 26



Air-end:

FSC 50



Controller:

EasyTRONIC IV (ET IV)



Fixed Speed

Controller:

EasyTRONIC IV (ET IV)



Fixed and variable Speed

Controller:

EasyTRONIC IV (ET IV)



Fixed and variable Speed



A-K-Max 15



A-K-Max 22 VS



A-K-Max 37 VS

15 kW

22 kW

37 kW

Available versions:

- floor mounted compressor
- Compressor + refrigeration dryer
- Compressor + vessel
- Compressor + vessel + refrigeration dryer

Available versions:

- floor mounted compressor
- Compressor + refrigeration dryer

Available versions:

- floor mounted compressor
- Compressor + refrigeration dryer

Air-end:

FSC 50



Air-end:

FS 100 (fixed speed)
FS 130 (variable speed, 7.5 bar)



Air-end:

FS 190 (fixed speed, 7.5 bar)
FS 260 (variable speed, 10-13 bar)



Controller:

EasyTRONIC IV (ET IV)



Controller:

EasyTRONIC IV (ET IV)



Controller:

EasyTRONIC IV (ET IV)



Fixed and variable Speed

Fixed and variable Speed

Fixed and variable Speed

A-K-MAX series – Directly coupled screw-type compressors for continuous duty and 100 % load.

- ▶ Directly coupled coaxial screw-type compressors guarantee absolute freedom from maintenance for the drivetrain with maximum energy efficiency
- ▶ Equipped with "EasyTRONIC IV" electronic control incl. pressure sensor operation as a factory standard, thus avoiding motor overload, reducing wear and extended the service life
- ▶ Excellent cooling performance and low noise thanks to thermostatically controlled radial fan
- ▶ Optimum operating temperatures thanks to thermostatically controlled fan, optimum cooling air guidance and generously dimensioned heat exchangers, thus ensuring a longer service life and less oil temperature fluctuation than with thermostat control
- ▶ Factory standard re-cooler reduces overhead for drying and filtering the compressed air generated
- ▶ Includes operating hours counter for logging load and post-run times; this ensures compliance with maintenance intervals – displays an automatic message to indicate that maintenance is due
- ▶ With sense of direction checking for the motor as a factory standard, thus avoiding possible damage during commissioning or after a change of location
- ▶ Equipped with a star delta circuitry as factory standard
- ▶ Service-friendly thanks to optimum accessibility and easy removal and installation of all components that require maintenance
- ▶ Small footprint facilitates transport and deployment



Fig. Model A-K-MAX 15-10 (IE3)



Fig. Model A-K-MAX 7.5-10-270F (IE3)

Type	Maximum pressure	Effective delivery volume	Motor output		Noise	Dimensions (LxWxH)	Connection	Vessel capacity	Weight	Art. no.
	bar		l/min	kW						
A-K-MAX series - directly coupled screw-type compressors (for floor installation)										
A-K-MAX 5.5-10 (IE3)	10	705	5.5	7.5	62	800 x 650 x 860	1/2"	–	160	2095204
A-K-MAX 7.5-10 (IE3)	10	1 050	7.5	10	62	800 x 650 x 860	1/2"	–	165	2095404
A-K-MAX 7.5-13 (IE3)	13	700	7.5	10	62	800 x 650 x 860	1/2"	–	165	2095406
A-K-MAX 1108 (IE3)	8	1 700	11	15	68	1 000 x 700 x 100	3/4"	–	230	2095602
A-K-MAX 1110 (IE3)	10	1 550	11	15	68	1 000 x 700 x 1 000	3/4"	–	230	2095604
A-K-MAX 1113 (IE3)	13	1 200	11	15	68	1 000 x 700 x 1 000	3/4"	–	230	2095606
A-K-MAX 1510 (IE3)	10	2 050	15	20	68	1 000 x 700 x 1 000	3/4"	–	250	2095804
A-K-MAX 1513 (IE3)	13	1 700	15	20	68	1 000 x 700 x 1 000	3/4"	–	250	2095806
A-K-MAX 2208 (IE3)	7.5	3 600	22	30	58	1 330 x 800 x 1 360	1 1/4"	–	430	2096202
A-K-MAX 3808 (IE3)	7.5	6 600	37	50	70	1 590 x 950 x 1 560	1 1/2"	–	920	2096402

*Sound pressure level at 1 m distance as per DIN 45635 T 13



- ▶ K models with integrated refrigerant dryer including automatic condensate drain
- ▶ Pressure dew point at 3°C, ambient temperature 25°C



Fig. Model A-K-MAX 7.5-10-500F K (IE3)



- Flexible oil line
- Maximum safety, even at high temperatures



- Cleaning of intake cooling and inlet air with a pre-filter pad
- For a cleaner interior



- Excellent cooling performance and low noise thanks to thermostatically controlled radial fan

Type	Maximum pressure bar	Effective delivery volume l/min	Motor output		Noise in dB(A)*	Dimensions (LxWxH) mm	Connection G	Vessel capacity l	Weight kg	Art. no.
			kW	PS						
A-K-MAX series - directly coupled screw-type compressors on vessel										
A-K-MAX 5.5-10-270F (IE3)	10	705	5.5	7.5	62	1 280 x 650 x 1 540	1/2"	270	255	2095224
A-K-MAX 7.5-10-270F (IE3)	10	1 050	7.5	10	62	1 280 x 650 x 1 540	1/2"	270	260	2095424
A-K-MAX 7.5-10-500F (IE3)	10	1 050	7.5	10	62	2 080 x 650 x 1 500	1/2"	500	305	2095434
A-K-MAX 1108-500F (IE3)	8	1 700	11	15	68	2 000 x 730 x 1 700	3/4"	500	380	2095632
A-K-MAX 1110-500F (IE3)	10	1 550	11	15	68	2 000 x 730 x 1 700	3/4"	500	380	2095634
A-K-MAX 1113-500F (IE3)	13	1 200	11	15	68	2 000 x 730 x 1 700	3/4"	500	380	2095636
A-K-MAX 1510-500F (IE3)	10	2 050	15	20	68	2 000 x 730 x 1 700	3/4"	500	400	2095834
A-K-MAX 1513-500F (IE3)	13	1 700	15	20	68	2 000 x 730 x 1 700	3/4"	500	400	2095836

Type	Maximum pressure bar	Effective delivery volume l/min	Motor output		Noise in dB(A)*	Dimensions (LxWxH) mm	Connection G	Vessel capacity l	Weight kg	Art. no.
			kW	PS						
A-K-MAX series - directly coupled screw-type compressors on vessel with attached refrigeration dryer										
A-K-MAX 5.5-10-270F K (IE3)	10	705	5.5	7.5	62	1 280 x 650 x 1 540	1/2"	270	290	2095264
A-K-MAX 7.5-10-270F K (IE3)	10	1 050	7.5	10	62	1 200 x 650 x 1 540	1/2"	270	295	2095464
A-K-MAX 7.5-10-500F K (IE3)	10	1 050	7.5	10	62	2 000 x 650 x 1 500	1/2"	500	340	2095474
A-K-MAX 1108-500F K (IE3)	8	1 700	11	15	68	2 000 x 730 x 1 700	3/4"	500	422	2095672
A-K-MAX 1110-500F K (IE3)	10	1 550	11	15	68	2 000 x 730 x 1 700	3/4"	500	422	2095674
A-K-MAX 1113-500F K (IE3)	13	1 200	11	15	68	2 000 x 730 x 1 700	3/4"	500	422	2095676
A-K-MAX 1510-500F K (IE3)	10	2 050	15	20	68	2 000 x 730 x 1 700	3/4"	500	442	2095874
A-K-MAX 1513-500F K (IE3)	13	1 700	15	20	68	2 000 x 730 x 1 700	3/4"	500	442	2095876

*Sound pressure level at a distance of 1 m as per DIN 45635 T 13

A-K-MAX VS Series - directly coupled screw-type compressors for permanent operation and 100 % load - including "SpeedTronic Control" frequency control as a factory standard.

- ▶ Directly coupled coaxial screw-type compressors guarantee absolute freedom from maintenance for the drivetrain with maximum energy efficiency
- ▶ Equipped with "EasyTRONIC II" electronic control incl. pressure sensor operation as a factory standard, thus avoiding motor overload, reducing wear and extended the service life
- ▶ Excellent cooling performance and low noise thanks to thermostatically controlled radial fan
- ▶ Optimum operating temperatures thanks to thermostatically controlled fan, optimum cooling air guidance and generously dimensioned heat exchangers, thus ensuring a longer service life and less oil temperature fluctuation than with thermostat control
- ▶ Factory standard re-cooler reduces overhead for drying and filtering the compressed air generated
- ▶ Includes operating hours counter for logging load and post-run times; this ensures compliance with maintenance intervals - displays an automatic message to indicate that maintenance is due
- ▶ With sense of direction checking for the motor as a factory standard, thus avoiding possible damage during commissioning or after a change of location
- ▶ Service-friendly thanks to optimum accessibility and easy removal and installation of all components that require maintenance
- ▶ Small footprint facilitates transport and deployment
- ▶ The electronic "SpeedTronic Control" monitors the motor and compressor speed.



Fig. Model A-K-MAX 3808 VS (IE3)



Fig. Model A-KMAX 1510-500 VS

- ▶ On a 500 litre vessel
- ▶ Fig. shows optimum accessibility of components, thus guaranteeing easy removal and installation of all components that require maintenance

Type	Maximum pressure	Effective delivery volume	Motor output		Noise	Dimensions (LxWxH)	Connection	Weight	Art. no.
	bar		l/min	kW					
A-KMAX-STC series - directly coupled screw-type compressors with frequency control and star-delta switch									
A-K-MAX 7.5-08 VS (IE3)	8	1 300 / 520	7.5	10	63	800 x 650 x 860	1/2"	175	2095502
A-K-MAX 7.5-10 VS (IE3)	10	1 100 / 440	7.5	10	63	800 x 650 x 860	1/2"	175	2095504
A-K-MAX 1108 VS (IE3)	8	1 700 / 680	11	15	68	1 000 x 700 x 1 000	3/4"	240	2095702
A-K-MAX 1110 VS (IE3)	10	1 550 / 620	11	15	68	1 000 x 700 x 1 000	3/4"	240	2095704
A-K-MAX 1508 VS (IE3)	8	2 400 / 950	15	20	68	1 000 x 700 x 1 000	3/4"	260	2095902
A-K-MAX 1510 VS (IE3)	10	2 100 / 840	15	20	68	1 000 x 700 x 1 000	3/4"	260	2095904
A-K-MAX 2208 VS (IE3)	7.5	3 600 / 1 170	22	30	62	1 330 x 800 x 1 360	1 1/4"	445	2096302
A-K-MAX 2210 VS (IE3)	10	3 010 / 1 170	22	30	60	1 330 x 800 x 1 360	1 1/4"	445	2096304
A-K-MAX 2213 VS (IE3)	13	2 560 / 965	22	30	60	1 330 x 800 x 1 360	1 1/4"	445	2096306
A-K-MAX 3808 VS (IE3)	7.5	6 600 / 2 680	37	50	70	1 590 x 950 x 1 560	1 1/2"	960	2096502
A-K-MAX 3810 VS (IE3)	10	5 400 / 1 715	37	50	69	1 590 x 950 x 1 560	1 1/2"	880	2096504
A-K-MAX 3813 VS (IE3)	13	4 520 / 1 705	37	50	66	1 590 x 950 x 1 560	1 1/2"	880	2096506

*Sound pressure level at 1 m distance as per DIN 45635 T 13

A-KMAX-VS Series with frequency control



- ▶ K models with integrated refrigerant dryer including automatic condensate drain
- ▶ Pressure dew point at 3°C, ambient temperature 25°C



- All oil lines are rubber hoses with steel mesh armoring
- This ensures maximum safety, even at high temperatures

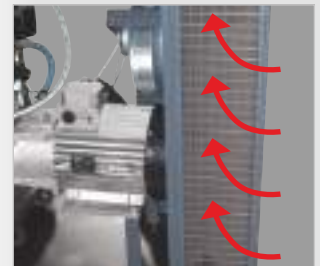

- Cleaning of intake cooling and inlet air with a pre-filter pad
- For a cleaner interior

Fig. Model A-KMAX 1508-500 VS K
With add-on refrigeration dryer on 500 l vessel
▶ Permanent protection against corrosion thanks to hot-dip galvanised vessel

Piston compressors

Screw-type compressors

System components

Compressed air maintenance units

Compressed air distribution

Tools

Energy savings thanks to frequency controlled compressors

▶ Based on frequency converter technology, the compressor's delivery volume adapts to match the actual consumption. The electronic control unit monitors the motor and compressor speed and keeps the line pressure constant. This gives users advance technology on a minimal footprint.

Your benefits

- ▶ Active energy savings
- ▶ Ideal for frequently changing compressed air consumption
- ▶ The speed-controlled compressor achieves maximum efficiency and keeps the line pressure constant, despite heavily fluctuating consumption.



Operating costs

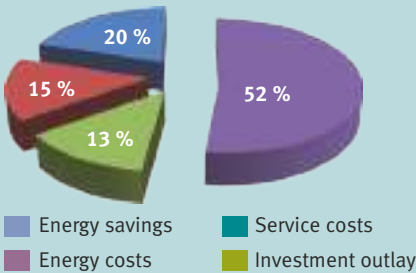

Energy costs

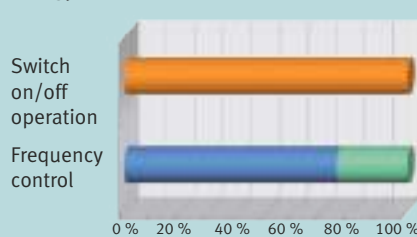

Pressure range

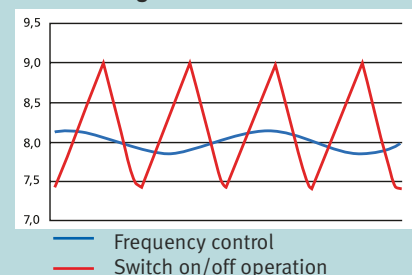

Type	Maximum pressure bar	Effective delivery volume l/min	Motor output kW PS	Noise in dB(A)*	Dimensions (L x W x H) mm	Connection G	Vessel capacity l	Weight kg	Art. no.
A-KMAX-500 VS series - directly coupled screw-type compressors with frequency control on vessel and star-delta switch									
A-K-MAX 7.5-08-270 VS (IE3)	8	1 300 / 520	7.5 10	63	1 200 x 650 x 1 540	1/2"	270	270	2095522
A-K-MAX 7.5-10-270 VS (IE3)	10	1 100 / 440	7.5 10	63	1 200 x 650 x 1 540	1/2"	270	270	2095524
A-K-MAX 1108-500 VS (IE3)	8	1 700 / 680	11 15	68	2 000 x 730 x 1 700	3/4"	500	390	2095732
A-K-MAX 1110-500 VS (IE3)	10	1 550 / 620	11 15	68	2 000 x 730 x 1 700	3/4"	500	390	2095734
A-K-MAX 1508-500 VS (IE3)	8	2 400 / 950	15 20	68	2 000 x 730 x 1 700	3/4"	500	410	2095932
A-K-MAX 1510-500 VS (IE3)	10	2 100 / 840	15 20	68	2 000 x 730 x 1 700	3/4"	500	410	2095934
A-KMAX- 500 KVS series - directly coupled screw-type compressors with frequency control and refrigeration dryer attached to vessel									
A-K-MAX 7.5-08-270 KVS (IE3)	8	1 300 / 520	7.5 10	63	1 200 x 650 x 1 540	1/2"	270	305	2095562
A-K-MAX 7.5-10-270 KVS (IE3)	10	1 100 / 440	7.5 10	63	1 200 x 650 x 1 540	1/2"	270	305	2095564
A-K-MAX 1108-500 KVS (IE3)	8	1 700 / 680	11 15	68	2 000 x 730 x 1 700	3/4"	500	432	2095772
A-K-MAX 1110-500 KVS (IE3)	10	1 550 / 620	11 15	68	2 000 x 730 x 1 700	3/4"	500	432	2095774
A-K-MAX 1508-500 KVS (IE3)	8	2 400 / 950	15 20	68	2 000 x 730 x 1 700	3/4"	500	452	2095972
A-K-MAX 1510-500 KVS (IE3)	10	2 100 / 840	15 20	68	2 000 x 730 x 1 700	3/4"	500	452	2095974

*Sound pressure level at a distance of 1 m as per DIN 45635 T 13

Regular maintenance A-K-MAX series 5.5-15 kW



		1 000 h * (or every year)	4 000 h * (or every year)	12 000 h
		· 1 Air filter cartridge	· 1 Air filter cartridges · 1 Oil filter cartridge · 1 Separator cartridge · 1 Oil check valve · 1 Prefilter · 1 Prefilter for switch cabinet (VS models only)	· 1 x 4 000 hrs kit · 1 Solenoid valve · 1 Minimum pressure valve (not VS models)
A-K-MAX 5.5-15 kW	Commodity group	1 000 h * (or every year)	KIT B	KIT E
A-K-MAX 5.5-10	285	0017092000N	0260KTB15E	0260KTE32E
A-K-MAX 5.5-13	285			
A-K-MAX 7.5-10	285			
A-K-MAX 7.5-13	285			
A-K-MAX 11-08	285	0017093000N	0260KTB16E	0260KTE33E
A-K-MAX 11-10	285			
A-K-MAX 11-13	285			
A-K-MAX 15-10	285			
A-K-MAX 15-13	285	0017092000N	0260KTB17E	0260KTE36E
K-MAX 7.5-08 VS	285			
K-MAX 7.5-10 VS	285			
K-MAX 11-08 VS	285			
K-MAX 11-10 VS	285	0017093000N	0260KTB18E	0260KTE37E
K-MAX 15-08 VS	285			
K-MAX 15-10 VS	285			

Designation	Art. no.	Designation	Art. no.
Air filter cartridge	0017092000N	LLK-B 11-15 VS K	0260KTB18E
Air filter cartridge	0017093000N	LLK-E 5.5-7.5 K	0260KTE32E
LLK-B 5.5-7.5 K	0260KTB15E	LLK-E 11-15 K	0260KTE33E
LLK-B 11-15 K	0260KTB16E	LLK-E 7.5 VS K	0260KTE36E
LLK-B 7.5 VS K	0260KTB17E	LLK-E 11-15 VS K	0260KTE37E

Individual components A-K-MAX series 5.5-15 kW

		4 000 h				12 000 h		24 000 h
		· Prefilter	· Prefilter for switch cabinet	· Oil check valve	· Intake regulator kit	· Minimum pressure valve	· Solenoid valve	· Air-end
A-K-MAX 5.5-15 kW	Commodity group	4 000 h				12 000 h		24 000 h
A-K-MAX 5.5-10	285	0151PT0014	not available	0012097000	0260260050	0347111000	0008195010	05303000700
A-K-MAX 5.5-13	285							05303000210
A-K-MAX 7.5-10	285							05303000705
A-K-MAX 7.5-13	285							05304000451
A-K-MAX 11-08	285	0160AC0014	not available	0012096000	0260260050	0347149010	0008195010	05304000461
A-K-MAX 11-10	285							05304000500
A-K-MAX 11-13	285							05304000400
A-K-MAX 15-10	285							05304000460
A-K-MAX 15-13	285	0151PT0014	0151PT0025	0012097000	0260260050	0347111000	0008195010	05303000200
K-MAX 7.5-08 VS	285							
K-MAX 7.5-10 VS	285							
K-MAX 11-08 VS	285	0160AC0014	0160PV0006	00012096000	0260260050	0347149010	0008195010	05304000510
K-MAX 11-10 VS	285							
K-MAX 15-08 VS	285							
K-MAX 15-10 VS	285							05304000410

Designation	Art. no.	Designation	Art. no.
Pre-Filter	0151PT0014	Minimum pressure valve	0347149010
Pre-Filter	0160AC0014	Solenoid valve	0008195010
Prefilter for switch cabinet	0151PT0025	Compressor	05303000210
Prefilter for switch cabinet	0160PV0006	Compressor	05303000705
Oil check valve	0012097000	Compressor	05304000451
Oil check valve	0012096000	Compressor	05304000461
Intake regulator kit	0260260050	Compressor	05304000510
Minimum pressure valve	0347111000	Compressor	05304000410

* We recommend changing the oil at the indicated interval or every year. We recommend use of our RotEnergyA-PLUS oil (NOT INCLUDED IN THE LONG LIFE KIT).

Regular maintenance A-K-MAX series 22 - 38 kW



		2 000 h (or every year)	4 000 h * (or every year)	12 000 h
		· 1 Air filter cartridge	<ul style="list-style-type: none"> · 1 Air filter cartridges · 1 Oil filter cartridge · 1 Separator cartridge (≤ 22 kW) · 2 Separator cartridges (≥ 37 kW) · 1 Oil check valve (≤ 22 kW) · 2 Oil check valves (≥ 37 kW) · 1 Prefilter · 1 Prefilter for switch cabinet (VS models only) 	<ul style="list-style-type: none"> · 1 x 4 000 hrs kit · 1 Solenoid valve · 1 Minimum pressure valve (not VS models)
A-K-MAX 22 - 38 kW	Commodity group	2 000 h * (or every year)	KIT B	KIT E
K-MAX 22-08	285	0017083000	0260KT61E	0260KTE7AE
K-MAX 38-08	285		0260KT62E	0260KTE8AE
K-MAX 22-08 VS	285		0260KT63E	0260KTE9AE
K-MAX 22-10 VS	285			
K-MAX 22-13 VS	285		0260KT64E	0260KTE1BE
K-MAX 38-08 VS	285			
K-MAX 38-10 VS	285			
K-MAX 38-13 VS	285			

Designation	Art. no.	Designation	Art. no.
Air filter cartridge	0017083000	LLK-E 22 K 8B	0260KTE7AE
LLK-B 22 K 8B	0260KT61E	LLK-E 38 K 8B	0260KTE8AE
LLK-B 38 K 8B	0260KT62E	LLK-E 22 VS K	0260KTE9AE
LLK-B 22 VS K	0260KT63E	LLK-E 38 VS K	0260KTE1BE
LLK-B 38 VS K	0260KT64E		

Individual components A-K-MAX series 22 - 38 kW

		4 000 h				12 000 h		24 000 h
		· Prefilter	· Prefilter for switch cabinet	· Oil check valve	· Intake regulator kit	· Minimum pressure valve	· Solenoid valve	· Air-end
A-K-MAX 22 - 38 kW	Commodity group	4 000 h				12 000 h		24 000 h
K-MAX 22-08	285	0160TV0035	not available	0012096000	0419253010	0247150000	0008195010	05307100010
K-MAX 38-08	285	0160NS0023		2 x 0012096000	0419265010	0213500030	0008465000	05_120065
K-MAX 22-08 VS	285	0160TV0035	0160DV0020	0012096000	0419253010	0247150000	0008195010	05308000000
K-MAX 22-10 VS	285							
K-MAX 22-13 VS	285	0160NS0023		2 x 0012096000	0419265010	0213500030	0008465000	05_120092
K-MAX 38-08 VS	285							
K-MAX 38-10 VS	285							
K-MAX 38-13 VS	285						05_120065	

Designation	Art. no.	Designation	Art. no.
Pre-Filter	0160TV0035	Minimum pressure valve	0213500030
Pre-Filter	0160NS0023	Solenoid valve	0008195010
Prefilter for switch cabinet	0160DV0020	Solenoid valve	0008465000
Oil check valve	0012096000	Compressor	05307100010
Intake regulator kit	0419253010	Compressor	05_120065
Intake regulator kit	0419265010	Compressor	05308000000
Minimum pressure valve	0247150000	Compressor	05_120092

* We recommend changing the oil at the indicated interval or every year. We recommend use of our RotEnergyA-PLUS oil (NOT INCLUDED IN THE LONG LIFE KIT).

Long Life Kits



Not suitable for IE 3 models!

A-PLUS



	Commodity group	1 000 h	4 000 h ** (or every year)	8 000 h	12 000 h	20 000 h
		· 1 Air filter cartridge	· 2 Air filter cartridges · 1 Oil filter cartridge · 1 Separator cartridge · 1 Oil check valve	· 1 x 4 000 hrs kit	· 1 x 4 000 hrs kit · 1 Belt · 1 Intake regulator kit · 1 Minimum pressure valve kit · 1 Solenoid valve · 5 Pipes	· 1 x 12 000 hrs kit · 1 Air-end
A-PLUS 2508	285	0017026000	0260KTA040	0260KTB040	0260KTC148	0260KTD148
A-PLUS 2510	285				0260KTC140	0260KTD140
A-PLUS 2513	285				0260KTC143	0260KTD143
A-PLUS 3008	285				0260KTC248	0260KTD248
A-PLUS 3010	285				0260KTC240	0260KTD240
A-PLUS 3013	285				0260KTC243	0260KTD240
A-PLUS 4008	285		0260KTA050	0260KTB050	0260KTC058	0260KTD058
A-PLUS 4010	285				0260KTC050	0260KTD050
A-PLUS 4013	285				0260KTC053	0260KTD053

** We recommend changing the oil at the indicated interval or every year.

We recommend use of our RotEnergyA-PLUS oil (NOT INCLUDED IN THE LONG LIFE KIT).

Designation	Art. no.	Designation	Art. no.
Air filter cartridge	0017026000	LK 12000H P/HT-JS 40(30) 8 B	0260KTC058
LK 4000H P/HT-JS 25-30(18,5-22)	0260KTA040	LK 12000H P/HT-JS 40(30) 10B	0260KTC050
LK 4000H P/HT-JS 40(30)	0260KTA050	LK 12000H P/HT-JS 40(30) 13 B	0260KTC053
LK 8000H P/HT-JS 25-30(18,5-22)	0260KTB040	LK 24000H P/HT-JS 25(18,5) 8 B	0260KTD148
LK 8000H P/HT-JS 40(30)	0260KTB050	LK 24000H P/HT-JS 25(18,5) 10 B	0260KTD140
LK 12000H P/HT-JS 25(18,5) 8 B	0260KTC148	LK 24000H P/HT-JS 25(18,) 13 B	0260KTD143
LK 12000H P/HT-JS 25(18,5) 10 B	0260KTC140	LK 24000H P/HT-JS 30(22) 8 B	0260KTD248
LK 12000H P/HT-JS 25(18,5) 13 B	0260KTC143	LK 24000H P/HT-JS 30(22)10-13B	0260KTD240
LK 12000H P/HT-JS 30(22) 8 B	0260KTC248	LK 24000H P/HT-JS 40(30) 8 B	0260KTD058
LK 12000H P/HT-JS 30(22) 10 B	0260KTC240	LK 24000H P/HT-JS 40(30) 10 B	0260KTD050
LK 12000H P/HT-JS 30(22) 13 B	0260KTC243	LK 24000H P/HT-JS 40(30) 13 B	0260KTD053

A-K-MID



	Commodity group	1 000 h	4 000 h ** (or every year)	12 000 h	24 000 h
		· 1 Air filter cartridge	· 2 Air filter cartridges · 1 Oil filter cartridge · 1 Separator cartridge · 1 Oil check valve · 1 Intake regulator kit · 1 Prefilter	· 1 x 4 000 hrs kit · 1 Minimum pressure valve · 1 Solenoid valve · 3 Pipes · 1 Motor bearing	· 1 x 12 000 hrs kit · 1 Air-end
A-K-MID 710	285	0017092000N	0260KTA100	0260KTC100	0260KTD100
A-K-MID 713	285				0260KTD105
A-K-MID 1010	285			0260KTC102	0260KTD102
A-K-MID 1013	285				0260KTD103

** We recommend changing the oil at the indicated interval or every year.

We recommend use of our RotEnergyA-PLUS oil (NOT INCLUDED IN THE LONG LIFE KIT).

Designation	Art. no.	Designation	Art. no.
Air filter cartridge	0017092000N	LK 24000H K-MID 7(5.5) 10 B	0260KTD100
LK 4000H K-MID	0260KTA100	LK 24000H K-MID 7(5.5) 13 B	0260KTD105
LK 12000H K-MID 7(5.5) 10-13 B	0260KTC100	LK 24000H K-MID 10(7.5) 10 B	0260KTD102
LK 12000H K-MID 10(7.5) 10-13B	0260KTC102	LK 24000H K-MID 10(7.5) 13 B	0260KTD103



Not suitable for IE 3 models!

A-K-MAX



Commodity group		1 000 h	4 000 h ** (or every year)	12 000 h	24 000 h
		· 1 Air filter cartridge	· 2 Air filter cartridges · 1 Oil filter cartridge · 1 Separator cartridge · 1 Oil check valve · 1 Intake regulator kit · 1 Prefilter	· 1 x 4 000 hrs kit · 1 Minimum pressure valve · 1 Solenoid valve · 3 Pipes · 1 Motor bearing	· 1 x 12 000 hrs kit · 1 Air-end
A-K-MAX 1508	285	0017093000N	0260KTB090	0260KTC090	0260KTD090
A-K-MAX 1513	285				0260KTD092
A-K-MAX 1510	285				0260KTD091
A-K-MAX 2013	285				0260KTD093
A-K-MAX 2010	285				

** We recommend changing the oil at the indicated interval or every year.
We recommend use of our RotEnergyA-PLUS oil (NOT INCLUDED IN THE LONG LIFE KIT).

Designation	Art. no.	Designation	Art. no.
Air filter cartridge	0017093000N	LK 24000H KMAX 15(11) 13 B	0260KTD092
LK 4000H KMAX	0260KTB090	LK 24000HKMAX15(11)10B 20(15)13	0260KTD091
LK 12000H KMAX	0260KTC090	LK 24000H KMAX 20(15) 10B	0260KTD093
LK 24000H KMAX 15(11) 8 B	0260KTD090		

A-PLUS SD



Commodity group		1 000 h	4 000 h ** (or every year)	12 000 h	24 000 h
		· 1 Air filter cartridge	· 2 Air filter cartridges · 1 Oil filter cartridge · 1 Separator cartridge · 1 Oil check valve · 1 Intake regulator kit · 1 Prefilter	· 1 x 4 000 hrs kit · 1 Belt · 1 Minimum pressure valve kit · 1 Solenoid valve · 4 Pipes	· 1 x 4 000 hrs kit · 1 Air-end
A-PLUS SD 2508	285	0017101000	0260KTA290	0260KTC290	0260KTD290
A-PLUS SD 3010	285			0260KTC295	
A-PLUS SD 2510	285				
A-PLUS SD 2513	285				
A-PLUS SD 3008	285				
A-PLUS SD 3013	285				

** We recommend changing the oil at the indicated interval or every year.
We recommend use of our RotEnergyA-PLUS oil (NOT INCLUDED IN THE LONG LIFE KIT).

Designation	Art. no.	Designation	Art. no.
Air filter cartridge	0017101000	LK 12000H A-PLUS SD 25-308/13(18-22)	0260KTC295
LK 4000H A-PLUS SD	0260KTA290	LK 24000H A-PLUS SD	0260KTD290
LK 12000H A-PLUS SD 25-30(18-22)8-10	0260KTC290		

More Long Life Kits

A-TOP

Designation	Art. no.
Air filter cartridge	0017083000
LK 4000H TPSTS 40-50(30-37)	0260KTA210
LK 8000H TPSTS 40-50(30-37)	0260KTB210
LK 12000H TPSTS 40-50(30-37)	0260KTC210
LK 20000H TPSTS 40-50(30-37)	0260KTD210
LK 20000H TPSTS 50(38) FS130	0260KTD215

A-GIGA SD

Designation	Art. no.
Air filter cartridge	0017067001
LK 4000H GPVSTSD 75(55)	0260KTA130
LK 4000H GPVSTSD 100(75)	0260KTA140
LK12000H GPVSTSD 75(55)8-10B	0260KTC150
LK12000H GPVSTSD 75(55)13B+VS	0260KTC151
LK 12000H GPVSTSD 100(75) 10 B	0260KTC155
LK12000H GPVSTSD 100(75)13B+VS	0260KTC158
LK 24000H GPVSTSD 75(55) 10 B	0260KTD150
LK24000H GPVSTSD 75(55)13B+VS	0260KTD151
LK 24000H GPVSTSD 100(75) 10 B	0260KTD155
LK4000H GPVSTSD 100(75) 8 B+VS	0260KTD158

A-MEGA SD

Designation	Art. no.
Air filter cartridge	0017083000
LK 4000H MPVSHSD 50-60(37-45)	0260KTA190
LK 4000H MPVSHSD 75(55)	0260KTA200
LK 8000H MPVSHSD 50-60(37-45)	0260KTB190
LK 8000H MPVSHSD 75(55)	0260KTB200
LK 12000H MPVSHSD 50-60(37-45)	0260KTC190
LK 12000H MPVSHSD 75(55)	0260KTC200
LK 20000H MPVSHSD 50-60(37-45)	0260KTD190
LK 20000H MPVSHSD 75(55)	0260KTD200

A-TERA SD

Designation	Art. no.
Long Life Kit A-TERA SD Series	On request

Components for compressed air systems



Pressure vessel arrays - for up to 400 litres of additional air supply

Maximum pressure vessel content on the smallest possible footprint – the space-saving solution

- ▶ Pressure vessel arrays available as 2x and 4x arrays
- ▶ All pressure vessel arrays available as a 13 bar variant with 75 l containers

- ▶ Enabling the second compressed air vessel doubles the pressure vessel volume, thus creating a greater compressed air reserve
- ▶ Helps to cover short-term peaks in compressed air requirements
- ▶ If required, individual compressed air vessels can be shut-off from the compressed

air supply using ball valves; this decreases the volume of the pressure vessel, thus building up the pressure faster

- ▶ Interior and exterior of pressure vessel hot-dip galvanised
- ▶ All pressure vessel arrays can be easily moved with a pallet truck.

The air reserve of a compressor with a 100 l pressure vessel is expandable up to 500 litres using Aircraft pressure vessel arrays.



AIRPROFI 853/100/10 H

- ▶ Connected via an optional flexible armoured hose to a dual pressure vessel array KB 2x100/10
- ▶ Pressure vessel arrays can be moved easily with a pallet truck



KB 2x75/13

Figure shows standard scope of delivery



KB 4x100/10

Figure shows standard scope of delivery

Model	KB 2x100/10	KB 2x75/13	KB 4x100/10	KB 4x75/13
article no.	2502102	2502132	2502104	2502134

Technical specifications

	KB 2x100/10	KB 2x75/13	KB 4x100/10	KB 4x75/13
Number of vessels	2	2	4	4
Vessel capacity	2 x 100 l	2 x 75 l	4 x 100 l	4 x 75 l
Maximum pressure	10 bar	13 bar	10 bar	13 bar
Pressure vessel connection	3/4"	3/4"	3/4"	3/4"
Dimensions (LxWxH) in mm	420 x 900 x 1 510	420 x 900 x 1 480	900 x 900 x 1 510	900 x 900 x 1 480



Fig. shows KB 4x100/10 with accessories

- (1) Condensate treatment with supply line
- (2) Automatic condensate drain with supply line
- (3) Flexible hoses as supply lines
- (4) Microfilter

Connection set BEKOMAT/ÖWAMAT

Scope of delivery:

Öwamat 10, Bekomat 31, all parts for connecting to the respective pressure vessel array, incl. factory assembly

Optional equipment	article no.
Connection set BEKOMAT/ÖWAMAT to KB2 x 100 / KB2 x 75	2504150
Connection set BEKOMAT/ÖWAMAT to KB4 x 100 / KB4 x 75	2504151

For important information and our full range of condensate treatment systems, see the Compressed air treatment section.



Compressed air vessels



Pressure vessels for your application – Made in Germany

Your benefits at a glance:

- ▶ Comprehensive technical consulting
- ▶ 50 years' experience
- ▶ Exacting quality requirements
- ▶ Certified as per DGRL and DIN ISO 9001
- ▶ Comprehensive technical documentation
- ▶ Sourcing of vessel documents after decades of use
- ▶ Long-standing reliable supplier and service provider
- ▶ High-performance surface finish
- ▶ Standard vessels always available from stock
- ▶ Shortest delivery times

Quality and sustainability, a matter of course for us!

- ▶ We guarantee premium manufacturing through strategic planning, precise investigation and documentation. With our state-of-the-art X-ray system, qualified specialist staff, and wide-ranging pressure, ultrasonic and magnetic powder testing options, we are in a position to monitor the manufacturing process in good time
- ▶ We are certified in line with DIN EN ISO 9001 and the Pressure Equipment Directive 2014/68/EU, Module H/H1 certified and have thus set up a quality assurance system that goes beyond the requirements of 9001 and HPO.
- ▶ Safety is our top priority in the manufacturing of pressure vessels. **For this reason, every vessel that we manufacture is implemented with a longitudinal outside weld and a matching longitudinal outside weld.**
- ▶ We follow a sustainable approach to the use of resources, thus contributing towards keeping our environment clean and intact.



Our standard



Galvanised pressure vessels

- ▶ flat/upright
- ▶ 50 litres - 10 000 litres
- ▶ 11 bar or 16 bar
- ▶ -10 °C to +50 °C



The welding procedure makes the difference

- ▶ Documented powder welding in a unique process for a safe weld



- ▶ Standard vessels from 50 litres to 3 000 litres in 11 and 16 bar versions are available for dispatch within two working days.

Compressed air vessels 11 and 16 bar

- ▶ Hot-dip galvanised inside and out
- ▶ Built as per EC Directive 87/404/EEC or PED 97/23/EC - AD 2000, module: H/H 1
- ▶ Operating conditions as per AD 2000 - S1 (10/2000) = start-up and ramp-down and 20 % pressure fluctuation range



Compressed air vessels in line with AD 2000/without fitting set

Upright type

Type	Pressure bar	Vessel capacity l	Manual/ Manhole	Weight kg	Art. no.
DB zinc plating 50/11 V	11	50	with plugs	25	2500618
DB zinc plating 50/16 V	16	50	with plugs	25	2500818
DB zinc plating 90/11 V	11	90	with plugs	40	2500620
DB zinc plating 90/16 V	16	90	with plugs	40	2500820
DB zinc plating 150/11 V	11	150	Recess	65	2500623
DB zinc plating 150/16 V	16	150	Recess	80	2500823
DB zinc plating 250/11 V	11	250	Recess	110	2500625
DB zinc plating 250/16 V	16	250	Recess	120	2500825
DB zinc plating 500/11 V	11	500	Recess	150	2500650
DB zinc plating 500/16 V	16	500	Recess	180	2500850
DB zinc plating 750/11 V	11	750	Recess	200	2500675
DB zinc plating 750/16 V	16	750	Recess	275	2500875
DB zinc plating 1000/11 V	11	1,000	Recess	315	2500680
DB zinc plating 1000/16 V	16	1,000	Recess	380	2500880
DB zinc plating 2000/11 V	11	2 000	Recess	500	2500700
DB zinc plating 2000/16 V	16	2 000	Recess	620	2500900
DB zinc plating 3000/11 V	11	3,000	Recess	660	2500710
DB zinc plating 3000/16 V	16	3,000	Recess	850	2500910
DB zinc plating 5000/11 V	11	5 000	Manhole	1,070	2500730
DB zinc plating 5000/16 V	16	5 000	Manhole	1,430	2500930

Horizontal type

Type	Pressure bar	Vessel capacity l	Manual/ Manhole	Weight kg	Art. no.
DB zinc plating 50/11 H	11	50	with plugs	25	2500619
DB zinc plating 50/16 H	16	50	with plugs	25	2500819
DB zinc plating 90/11 H	11	90	with plugs	35	2500622
DB zinc plating 90/16 H	16	90	with plugs	35	2500822
DB zinc plating 150/11 H	11	150	with plugs	70	2500624
DB zinc plating 150/16 H	16	150	with plugs	95	2500824
DB zinc plating 250/11 H	11	250	Recess	100	2500626
DB zinc plating 250/16 H	16	250	Recess	120	2500826
DB zinc plating 500/11 H	11	500	Recess	150	2500651
DB zinc plating 500/16 H	16	500	Recess	150	2500851
DB zinc plating 750/11 H	11	750	Recess	210	2500676
DB zinc plating 750/16 H	16	750	Recess	280	2500876
DB zinc plating 1000/11 H	11	1,000	2 x recess	300	2500681
DB zinc plating 1000/16 H	16	1,000	2 x recess	380	2500881
DB zinc plating 2000/11 H	11	2 000	2 x recess	480	2500701
DB zinc plating 2000/16 H	16	2 000	2 x recess	620	2500901
DB zinc plating 5000/11 H	11	5 000	Manhole	1 020	2500731
DB zinc plating 5000/16 H	16	5 000	Manhole	1 360	2500931



Basic fitting set

Basic fitting set 1/2" up to 750 l. 11 bar

- 1x three-way ball valve 1/2" with flange 60x25x10 (ASFIG34MS12)
- 1x low pressure ball valve 1/2" brass (H1502004000)
- 1x Manometer T 1/2" 16 bar, set to 11 bar (WW9022619)
- 1x safety valve HSV 1/2", 11 bar (H0620504110)
- 1x elbow 90°, 1/2", galvanized (FF4015889014051)

Use with pressure vessel size	Pressure (bar)	Compressed air connection	Art. no.
up to 750 litres	11	1/2"	2500611

Basic fitting set 1/2" up to 750 l. 16 bar

- 1x three-way ball valve 1/2" with flange 60x25x10 (ASFIG34MS12)
- 1x low pressure ball valve 1/2" brass (H1502004000)
- 1x Manometer T 1/2" 25 bar, set to 16 bar (WW9012605)
- 1x safety valve HSV 1/2", 16 bar (H0620504160)
- 1x elbow 90°, 1/2", galvanized (FF4015889014051)

Use with pressure vessel size	Pressure (bar)	Compressed air connection	Art. no.
up to 750 litres	16	1/2"	2500616

Basic fitting set 1" up to 1,000 l. 11 bar

- 1x three-way ball valve 1/2" with flange 60x25x10 (ASFIG34MS12)
- 1x low pressure ball valve 1" brass (H1502010000)
- 1x Manometer T 1/2" 16 bar, set to 11 bar (WW9022619)
- 1x safety valve HSV 1", 11 bar (H0620510110) NL/min. 1432
- 1x elbow 90°, 1", galvanized (FF4015889014259)

Use with pressure vessel size	Pressure (bar)	Compressed air connection	Art. no.
as of 1,000 litres	11	1"	2500612

Basic fitting set 1" up to 1,000 l. 16 bar

- 1x three-way ball valve 1/2" with flange 60x25x10 (ASFIG34MS12)
- 1x low pressure ball valve 1" brass (H1502010000)
- 1x Manometer T 1/2" 25 bar, set to 16 bar (WW9012605)
- 1x safety valve HSV 1", 16 bar (H0620510160) NL/min. 2032
- 1x elbow 90°, 1", galvanized (FF4015889014259)

Use with pressure vessel size	Pressure (bar)	Compressed air connection	Art. no.
as of 1000 litres	16	1"	2500617

50 l upright

Upright type

Type	Pressure bar	Vessel capacity l	Manual/ Manhole	Weight kg	Art. no.
DB zinc plating 50/11 V	11	50	with plugs	25	2500618
DB zinc plating 50/16 V	16	50	with plugs	25	2500818

Fitting set, complete for DB VZ 50/11 V

For compressed air vessels		
Pressure	air vessels	Art. no.
11 bar	50 l upright	2500510
pieces	Type	
① 3	Reducing nipple R 1"(OT)-RP 1/2"(IT)	
② 1	Safety valve 1/2" 10 bar	
③ 2	Ball valve 3/4" IT/OT	
④ 2	Angle 90° 1/2" IT/OT	
⑤ 1	Pressure gauge 1/2" 0-16 bar, upright	
⑥ 1	Ball valve 1/2" IT/OT	

Fitting set, complete for DB VZ 50/16 V

For compressed air vessels		
Pressure	air vessels	Art. no.
16 bar	50 l upright	2500511
pieces	Type	
① 3	Reducing nipple R 1"(OT)-RP 1/2"(IT)	
② 1	Safety valve 1/2" 15 bar	
③ 2	Ball valve 3/4" IT/OT	
④ 2	Angle 90° 1/2" IT/OT	
⑤ 1	Pressure gauge 1/2" 0-25 bar, upright	
⑥ 1	Ball valve 1/2" IT/OT	

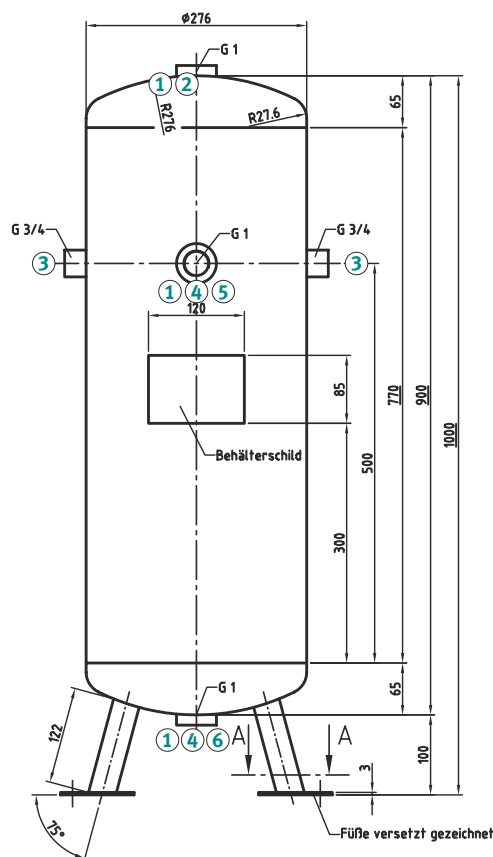

DB VZ 50/11 V / DB VZ 50/16 V

Upright type

Type	Pressure bar	Vessel capacity l	Manual/ Manhole	Weight kg	Art. no.
DB zinc plating 90/11 V	11	90	with plugs	40	2500620
DB zinc plating 90/16 V	16	90	with plugs	40	2500820

Fitting set, complete for DB VZ 90/11 V

For compressed air vessels		
Pressure	air vessels	Art. no.
11 bar	90 l upright	2500515
pieces	Type	
① 2	Reducing nipple R 2"(OT)-RP 1/2"(IT)	
② 1	Safety valve 1/2" 10 bar	
③ 3	Ball valve 1/2" IT/OT	
④ 1	Pressure gauge 1/4" 0-16 bar, flat	
⑤ 2	Blind plug 3/8"	
⑥ 1	Angle 90° 1/2" IT/OT	

Fitting set, complete for DB VZ 90/16 V

For compressed air vessels		
Pressure	air vessels	Art. no.
16 bar	90 l upright	2500516
pieces	Type	
① 2	Reducing nipple R 2"(OT)-RP 1/2"(IT)	
② 1	Safety valve 1/2" 15 bar	
③ 3	Ball valve 1/2" IT/OT	
④ 1	Pressure gauge 1/4" 0-25 bar, upright	
⑤ 2	Blind plug 3/8"	
⑥ 1	Angle 90° 1/2" IT/OT	

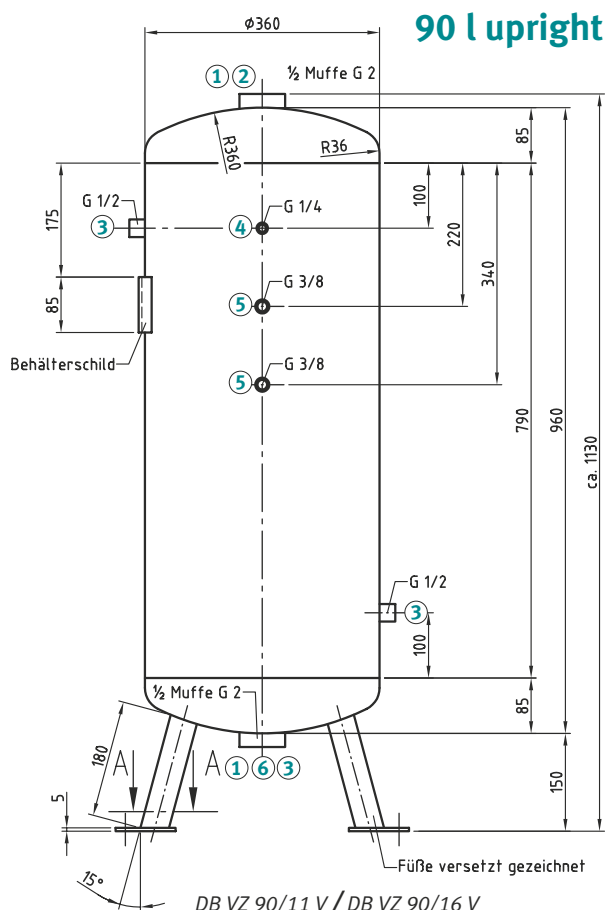

DB VZ 90/11 V / DB VZ 90/16 V

150 l upright

Upright type

Type	Pressure bar	Vessel capacity l	Manual/ Manhole	Weight kg	Art. no.
DB zinc plating 150/11 V	11	150	Recess	65	2500623
DB zinc plating 150/16 V	16	150	Recess	80	2500823

Fitting set, complete for DB VZ 150/11 V

For compressed		
Pressure	air vessels	Art. no.
11 bar	150 l upright	2500520
pieces	Type	
①	2 Reducing nipple R 1 1/2" (OT)-RP 1/2" (IT)	
②	1 Safety valve 1/2" 10 bar	
③	4 Dummy plug 1 1/4"	
④	1 Reducing nipple R 1" (OT)-RP 1/2" (IT)	
⑤	2 Angle 90° 1/2" IT/OT	
⑥	1 Pressure gauge 1/2" 0-16 bar, upright	
⑦	1 Three-way ball valve 1/2"	
⑧	2 Ball valve 1/2" IT/OT	

Fitting set, complete for DB VZ 150/16 V

For compressed		
Pressure	air vessels	Art. no.
16 bar	150 l upright	2500521
pieces	Type	
①	2 Reducing nipple R 1 1/2" (OT)-RP 1/2" (IT)	
②	1 Safety valve 1/2" 15 bar	
③	4 Dummy plug 1 1/4"	
④	1 Reducing nipple R 1" (OT)-RP 1/2" (IT)	
⑤	2 Angle 90° 1/2" IT/OT	
⑥	1 Pressure gauge 1/2" 0-25 bar, upright	
⑦	1 Three-way ball valve 1/2"	
⑧	2 Ball valve 1/2" IT/OT	

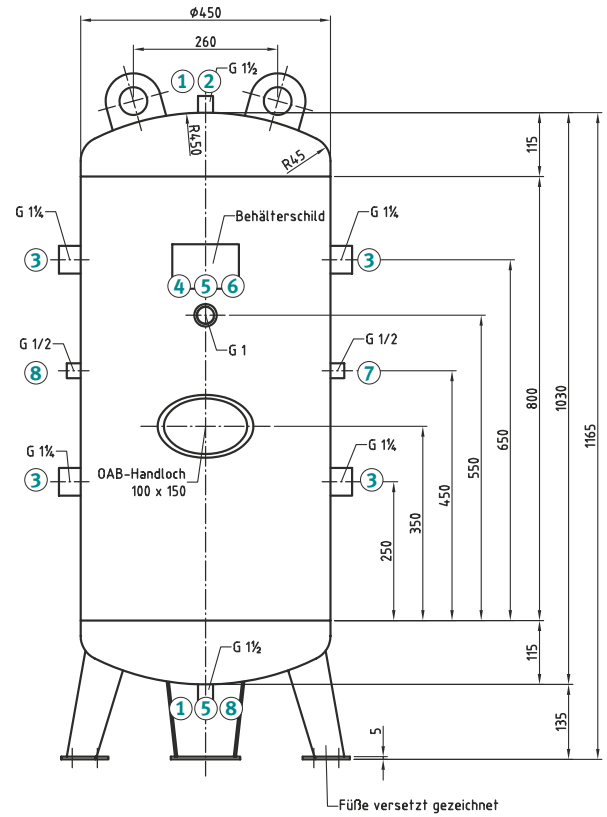

DB VZ 150/11 V / DB VZ 150/16 V

Upright type

Type	Pressure bar	Vessel capacity l	Manual/ Manhole	Weight kg	Art. no.
DB zinc plating 250/11 V	11	250	Recess	110	2500625
DB zinc plating 250/16 V	16	250	Recess	120	2500825

Fitting set, complete for DB VZ 250/11 V

For compressed		
Pressure	air vessels	Art. no.
11 bar	250 l upright	2500525
pieces	Type	
①	2 Reducing nipple R 1 1/2" (OT)-RP 1/2" (IT)	
②	1 Safety valve 1/2" 10 bar	
③	2 Dummy plug 1 1/4"	
④	1 Reducing nipple R 1" (OT)-RP 1/2" (IT)	
⑤	2 Angle 90° 1/2" IT/OT	
⑥	1 Pressure gauge 1/2" 0-16 bar, upright	
⑦	1 Blind plug 1/2"	
⑧	1 Three-way ball valve 1/2" OT/2xIT	
⑨	2 Ball valve 1 1/4" IT/OT	
⑩	1 Ball valve 1/2" IT/OT	

Fitting set, complete for DB VZ 250/16 V

For compressed		
Pressure	air vessels	Art. no.
16 bar	250 l upright	2500526
pieces	Type	
①	2 Reducing nipple R 1 1/2" (OT)-RP 1/2" (IT)	
②	1 Safety valve 1/2" 15 bar	
③	2 Dummy plug 1 1/4"	
④	1 Reducing nipple R 1" (OT)-RP 1/2" (IT)	
⑤	2 Angle 90° 1/2" IT/OT	
⑥	1 Pressure gauge 1/2" 0-25 bar, upright	
⑦	1 Blind plug 1/2"	
⑧	1 Three-way ball valve 1/2"	
⑨	2 Ball valve 1 1/4" IT/OT	
⑩	1 Ball valve 1/2" IT/OT	

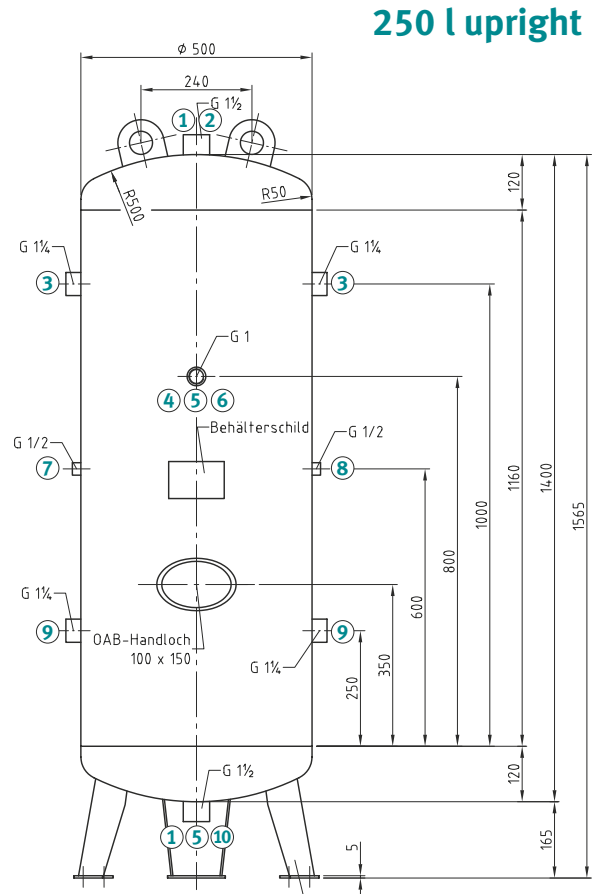

DB VZ 250/11 V / DB VZ 250/16 V

Upright type

Type	Pressure bar	Vessel capacity l	Manual/ Manhole	Weight kg	Art. no.
DB zinc plating 500/11 V	11	500	Recess	150	2500650
DB zinc plating 500/16 V	16	500	Recess	180	2500850

500 l upright

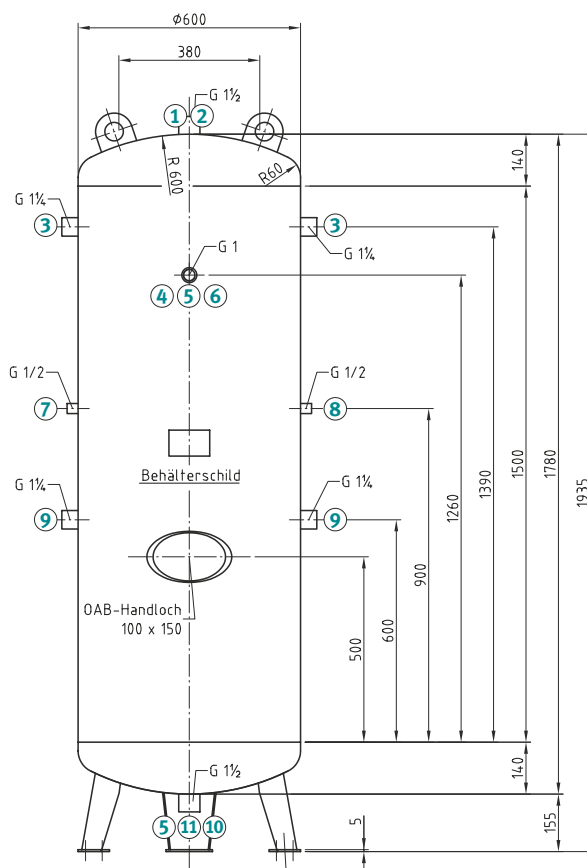

DB VZ 500/11 V / DB VZ 500/16 V FüÙe versetzt gezeichnet

Fitting set, complete for DB VZ 500/11 V

For compressed air vessels		
Pressure	air vessels	Art. no.
11 bar	500 l upright	2500530
pieces	Type	
1	Reducing nipple R 1 1/2"(OT)-RP 3/4"(IT)	
2	Safety valve 3/4" 10 bar	
3	Dummy plug 1 1/4"	
4	Reducing nipple R 1"(OT)-RP 1/2"(IT)	
5	Angle 90° 1/2" IT/OT	
6	Pressure gauge 1/2" 0-16 bar, upright	
7	Blind plug 1/2"	
8	Three-way ball valve 1/2"	
9	Ball valve 1 1/4" IT/OT	
10	Reducing nipple R 1 1/2"(OT)-RP 1/2"(IT)	
11	Ball valve 1/2" IT/OT	

Fitting set, complete for DB VZ 500/16 V

For compressed air vessels		
Pressure	air vessels	Art. no.
16 bar	500 l upright	2500531
pieces	Type	
1	Reducing nipple R 1 1/2"(OT)-RP 3/4"(IT)	
2	Safety valve 3/4" 15 bar	
3	Dummy plug 1 1/4"	
4	Reducing nipple R 1"(OT)-RP 1/2"(IT)	
5	Angle 90° 1/2" IT/OT	
6	Pressure gauge 1/2" 0-25 bar, upright	
7	Blind plug 1/2"	
8	Three-way ball valve 1/2"	
9	Ball valve 1 1/4" IT/OT	
10	Reducing nipple R 1 1/2"(OT)-RP 1/2"(IT)	
11	Ball valve 1/2" IT/OT	

Upright type

Type	Pressure bar	Vessel capacity l	Manual/ Manhole	Weight kg	Art. no.
DB zinc plating 750/11 V	11	750	Recess	200	2500675
DB zinc plating 750/16 V	16	750	Recess	275	2500875

750 l upright

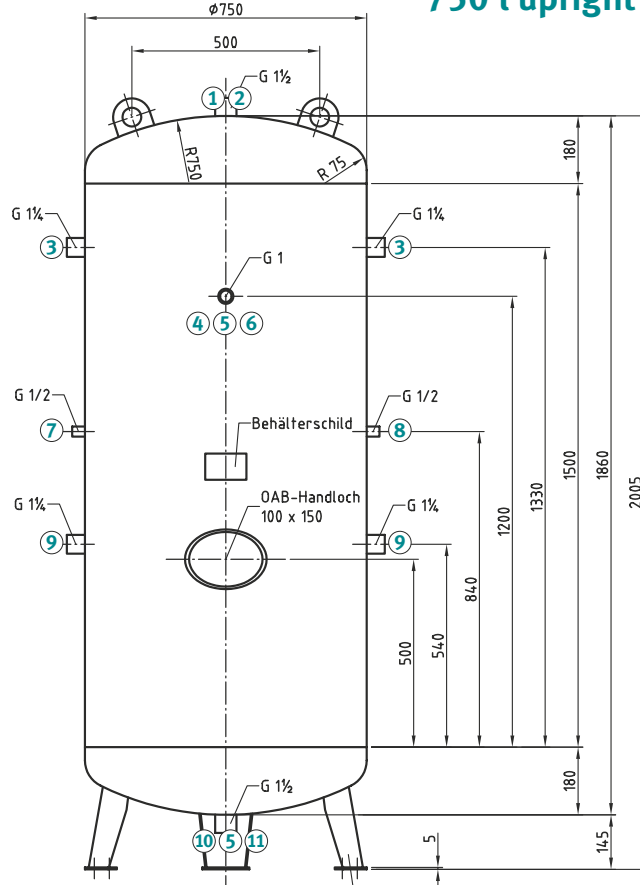

DB VZ 750/11 V / DB VZ 750/16 V FüÙe versetzt gezeichnet

Fitting set, complete for DB VZ 750/11 V

For compressed air vessels		
Pressure	air vessels	Art. no.
11 bar	750 l upright	2500535
pieces	Type	
1	Reducing nipple R 1 1/2"(OT)-RP 3/4"(IT)	
2	Safety valve 3/4" 10 bar	
3	Dummy plug 1 1/4"	
4	Reducing nipple R 1"(OT)-RP 1/2"(IT)	
5	Angle 90° 1/2" IT/OT	
6	Pressure gauge 1/2" 0-16 bar, upright	
7	Blind plug 1/2"	
8	Three-way ball valve 1/2"	
9	Ball valve 1 1/4" IT/OT	
10	Reducing nipple R 1 1/2"(OT)-RP 1/2"(IT)	
11	Ball valve 1/2" IT/OT	

Fitting set, complete for DB VZ 750/16 V

For compressed air vessels		
Pressure	air vessels	Art. no.
16 bar	750 l upright	2500536
pieces	Type	
1	Reducing nipple R 1 1/2"(OT)-RP 3/4"(IT)	
2	Safety valve 3/4" 15 bar	
3	Dummy plug 1 1/4"	
4	Reducing nipple R 1"(OT)-RP 1/2"(IT)	
5	Angle 90° 1/2" IT/OT	
6	Pressure gauge 1/2" 0-25 bar, upright	
7	Blind plug 1/2"	
8	Three-way ball valve 1/2"	
9	Ball valve 1 1/4" IT/OT	
10	Reducing nipple R 1 1/2"(OT)-RP 1/2"(IT)	
11	Ball valve 1/2" IT/OT	

Upright type

Type	Pressure bar	Vessel capacity l	Manual/ Manhole	Weight kg	Art. no.
DB zinc plating 1000/11 V	11	1,000	Recess	315	2500680
DB zinc plating 1000/16 V	16	1,000	Recess	380	2500880

1,000 l upright

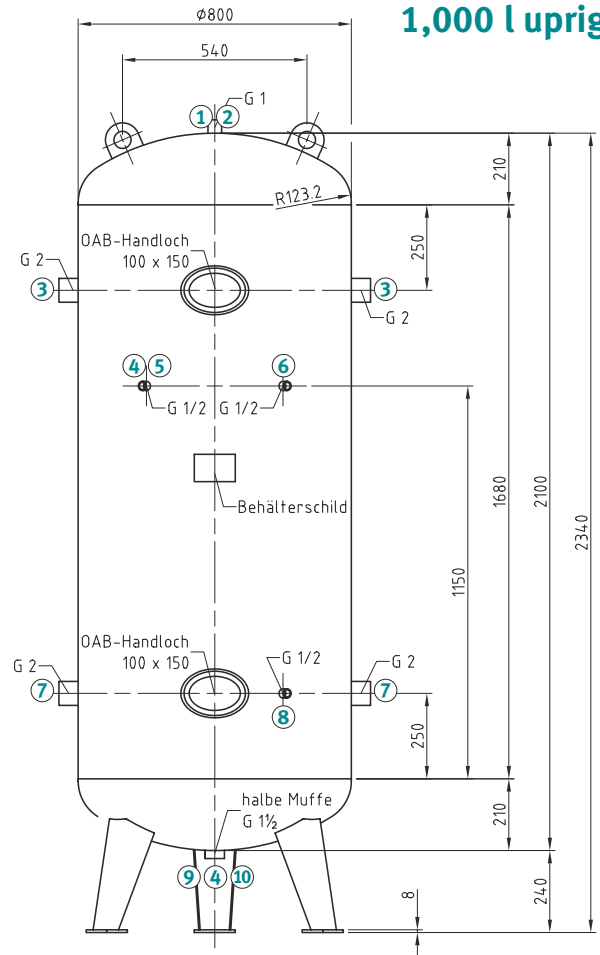

DB VZ 1000/11 V / DB VZ 1000/16 V

Fitting set, complete for DB VZ 1000/11 V

For compressed

Pressure	air vessels	Art. no.
11 bar	1,000 l upright	2500540

pieces	Type
1	Reducing nipple R 1" (OT)-RP 3/4" (IT)
1	Safety valve 3/4" 10 bar
2	Dummy plug 2"
2	Angle 90° 1/2" IT/OT
1	Pressure gauge 1/2" 0-16 bar, upright
1	Three-way ball valve 1/2"
2	Ball valve 2"
1	Blind plug 1/2"
1	Reducing nipple R 1 1/2" (OT)-RP 1/2" (IT)
1	Ball valve 1/2" IT/OT

Fitting set, complete for DB VZ 1000/16 V

For compressed

Pressure	air vessels	Art. no.
16 bar	1,000 l upright	2500541

pieces	Type
1	Reducing nipple R 1" (OT)-RP 3/4" (IT)
1	Safety valve 3/4" 15 bar
2	Dummy plug 2"
2	Angle 90° 1/2" IT/OT
1	Pressure gauge 1/2" 0-25 bar, upright
1	Three-way ball valve 1/2"
2	Ball valve 2"
1	Blind plug 1/2"
1	Reducing nipple R 1 1/2" (OT)-RP 1/2" (IT)
1	Ball valve 1/2" IT/OT

Upright type

Type	Pressure bar	Vessel capacity l	Manual/ Manhole	Weight kg	Art. no.
DB zinc plating 2000/11 V	11	2 000	Recess	500	2500700
DB zinc plating 2000/16 V	16	2 000	Recess	620	2500900

2,000 l upright

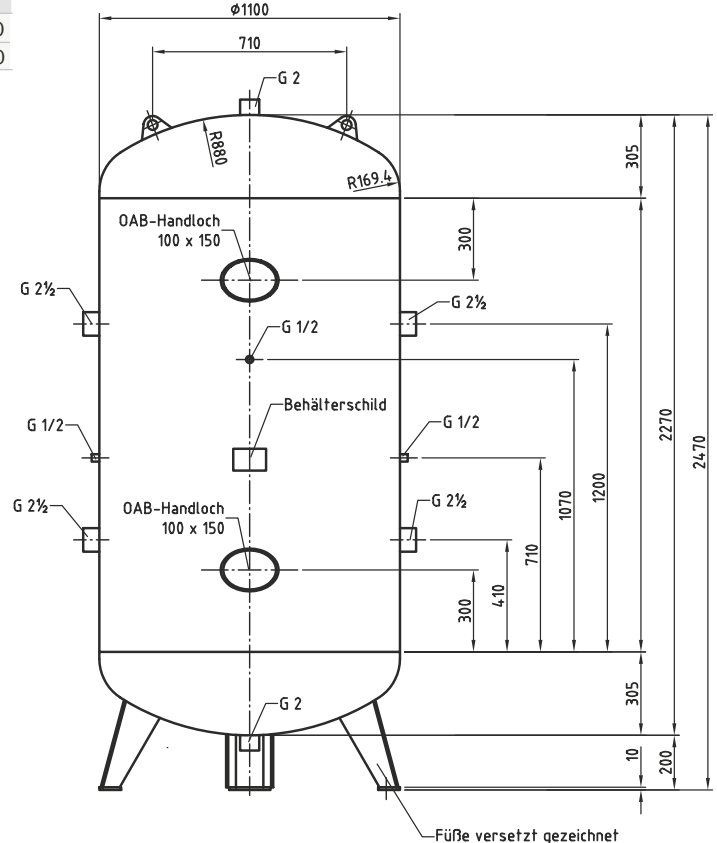

DB VZ 2000/11 V / DB VZ 2000/16 V

3,000 l upright

Upright type

Type	Pressure	Vessel capacity	Manual/Manhole	Weight	Art. no.
	bar	l		kg	
DB zinc plating 3000/11 V	11	3,000	Recess	660	2500710
DB zinc plating 3000/16 V	16	3,000	Recess	850	2500910

5,000 l upright

Upright type

Type	Pressure	Vessel capacity	Manual/Manhole	Weight	Art. no.
	bar	l		kg	
DB zinc plating 5000/11 V	11	5 000	Manhole	1,070	2500730
DB zinc plating 5000/16 V	16	5 000	Manhole	1,430	2500930

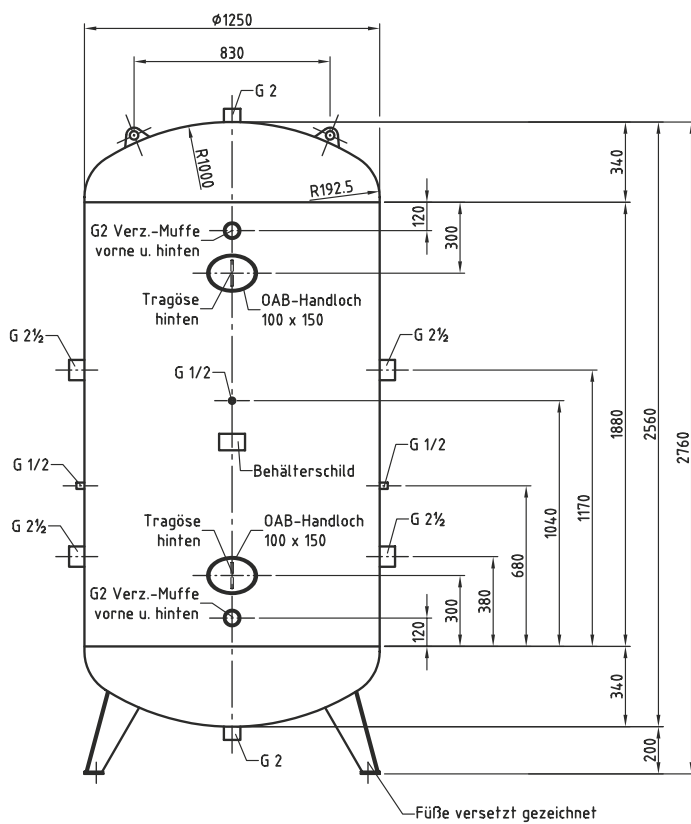

DB VZ 3000/11 V / DB VZ 3000/16 V

Basic fitting set 1" as of 1000 l, 11 bar

- 1x three-way ball valve 1/2" with flange 60x25x10 (ASFIG34MS12)
- 1x low pressure ball valve 1" brass (H1502010000)
- 1x Manometer T 1/2" 16 bar, set to 11 bar (WW9022619)
- 1x safety valve HSV 1", 11 bar (H0620510110) NL/min. 1432
- 1x elbow 90°, 1", galvanized (FF4015889014259)

Use with pressure vessel size	Pressure (bar)	Compressed air connection	Art. no.
as of 1,000 litres	11	1"	2500612

Basic fitting set 1" as of 1000 l, 16 bar

- 1x three-way ball valve 1/2" with flange 60x25x10 (ASFIG34MS12)
- 1x low pressure ball valve 1" brass (H1502010000)
- 1x Manometer T 1/2" 25 bar, set to 16 bar (WW9012605)
- 1x safety valve HSV 1", 16 bar (H0620510160) NL/min. 2032
- 1x elbow 90°, 1", galvanized (FF4015889014259)

Use with pressure vessel size	Pressure (bar)	Compressed air connection	Art. no.
as of 1000 litres	16	1"	2500617

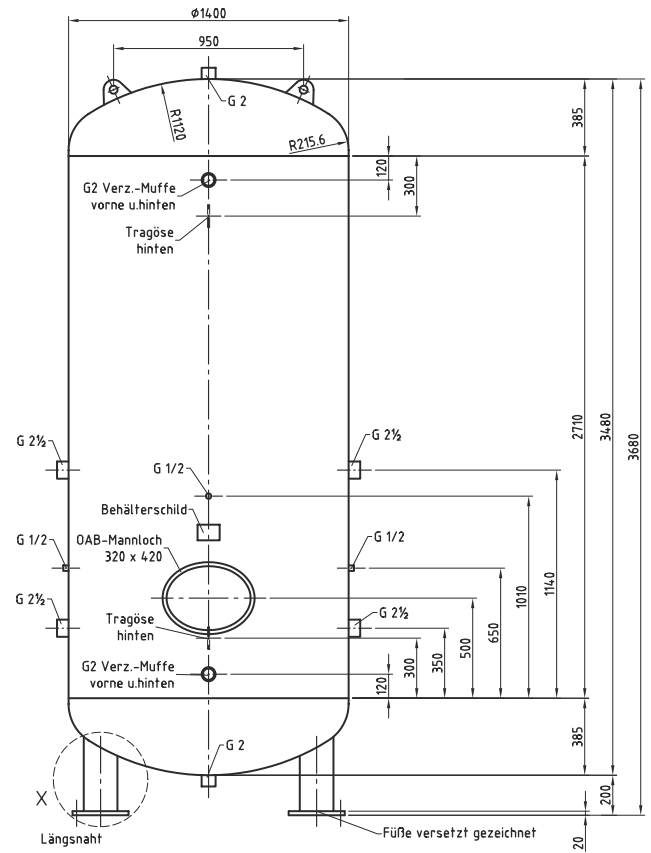

DB VZ 5000/11 V / DB VZ 5000/16 V

Components for compressed air systems



Teflon sealing tape	Art. no.
12 m x 12 mm x 0.1 mm 60 g/m ² (PU 10)	2500020



Dummy plug, brass	Art. no.
Blind plug 1/8"	PU25 2200211
Blind plug 1/4"	PU25 2200212
Blind plug 3/8"	PU25 2200213
Blind plug 1/2"	PU25 2200214



Dummy plug, galvanized steel	Art. no.
Dummy plug 1/4"	PU1 22511667
Dummy plug 1/2"	PU1 22511668
Dummy plug 2"	PU1 22511669
Dummy plug 2 1/2"	PU1 22511671



Screw plug	Art. no.
------------	----------

Sealing screw 1/4" thread with hexagon socket as per ISO 228-1, brass CW614N / SW22 22525292

Sealing screw T 3/8" thread brass, with hexagon socket 8 mm as per ISO 228-1, Brass CW614N/size 8 22525293

Sealing screw 1/2" thread Hex. head as per ISO 228-1, Brass CW614N / SW24 22525298

Sealing screw 3/4" thread Cylindrical outside thread / nickel plated brass/size 17 22525299 N

Screw plug T 1" Nickel plated brass, cylindrical outside as per ISO 228-1/size 36 225252100 N

50 l flat

Horizontal type

Type	Pressure bar	Vessel capacity l	Manual/ Manhole	Weight kg	Art. no.
DB zinc plating 50/11 H	11	50	with plugs	25	2500619
DB zinc plating 50/16 H	16	50	with plugs	25	2500819

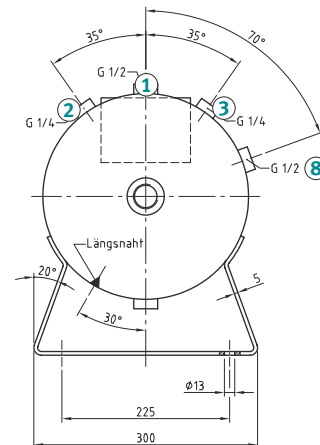
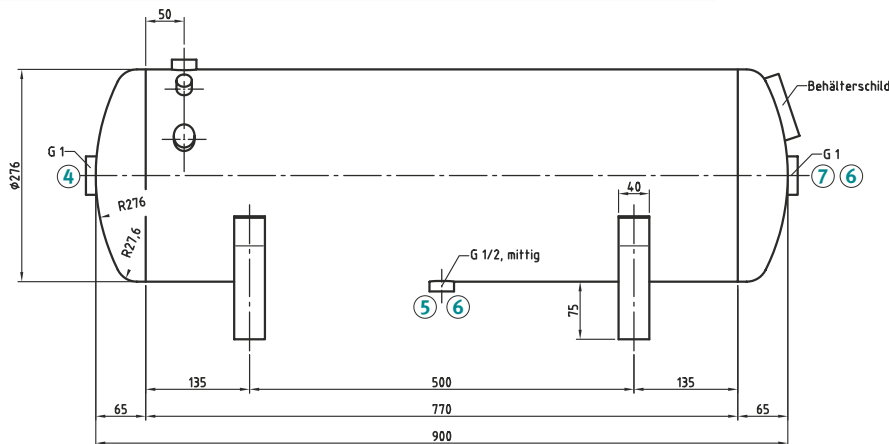

DB VZ 50/11 H / DB VZ 50/16 H

Fitting set, complete for DB VZ 50/11 H

For compressed		
Pressure	air vessels	Art. no.
11 bar	50 l flat	2500512
pieces	Type	
1	Safety valve 1/2" 10 bar	
1	Blind plug 1/4"	
1	Pressure gauge 1/4" 0-16 bar, flat	
1	Dummy plug 1"	
1	Angle 90° 1/2" IT/OT	
2	Ball valve 1/2" IT/OT	
1	Reducing nipple R 1"(OT)-RP 1/2"(IT)	
1	Blind plug 1/2"	

Fitting set, complete for DB VZ 50/16 H

For compressed		
Pressure	air vessels	Art. no.
16 bar	50 l flat	2500513
pieces	Type	
1	Safety valve 1/2" 15 bar	
1	Blind plug 1/4"	
1	Pressure gauge 1/4" 0-25 bar, flat	
1	Dummy plug 1"	
1	Angle 90° 1/2" IT/OT	
2	Ball valve 1/2" IT/OT	
1	Reducing nipple R 1"(OT)-RP 1/2"(IT)	
1	Blind plug 1/2"	

Horizontal type

Type	Pressure bar	Vessel capacity l	Manual/ Manhole	Weight kg	Art. no.
DB zinc plating 90/11 H	11	90	with plugs	35	2500622
DB zinc plating 90/16 H	16	90	with plugs	35	2500822

90 l flat

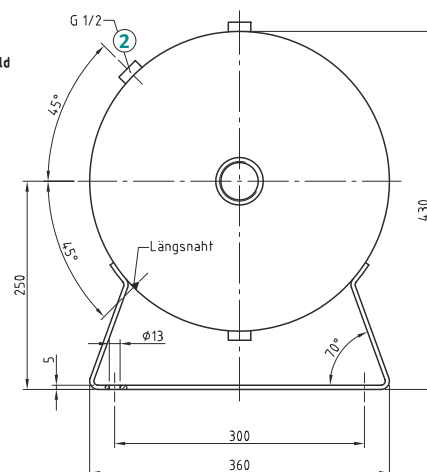
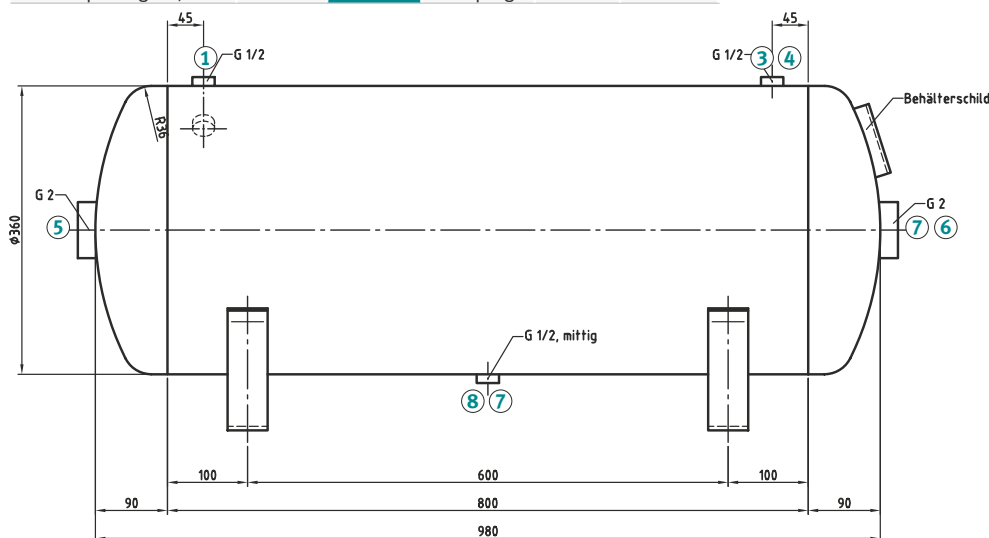

DB VZ 90/11 H / DB VZ 90/16 H

Fitting set, complete for DB VZ 90/11 H

For compressed		
Pressure	air vessels	Art. no.
11 bar	90 l flat	2500517
pieces	Type	
1	Safety valve 1/2" 10 bar	
1	Blind plug 1/2"	
1	Reducing nipple R 1/2"(OT)-RP 1/4"(IT)	
1	Pressure gauge 1/4" 0-16 bar, upright	
1	Dummy plug 2"	
1	Reducing nipple R 2"(OT)-RP 1/2"(IT)	
2	Ball valve 1/2" IT/OT	
1	Angle 90° 1/2" IT/OT	

Fitting set, complete for DB VZ 90/16 H

For compressed		
Pressure	air vessels	Art. no.
16 bar	90 l flat	2500518
pieces	Type	
1	Safety valve 1/2" 15 bar	
1	Blind plug 1/2"	
1	Reducing nipple R 1/2"(OT)-RP 1/4"(IT)	
1	Pressure gauge 1/4" 0-25 bar, upright	
1	Dummy plug 2"	
1	Reducing nipple R 2"(OT)-RP 1/2"(IT)	
2	Ball valve 1/2" IT/OT	
1	Angle 90° 1/2" IT/OT	

Components for compressed air systems

150 l flat

Horizontal type

Type	Pressure bar	Vessel capacity l	Manual/ Manhole	Weight kg	Art. no.
DB zinc plating 150/11 H	11	150	with plugs	70	2500624
DB zinc plating 150/16 H	16	150	with plugs	95	2500824

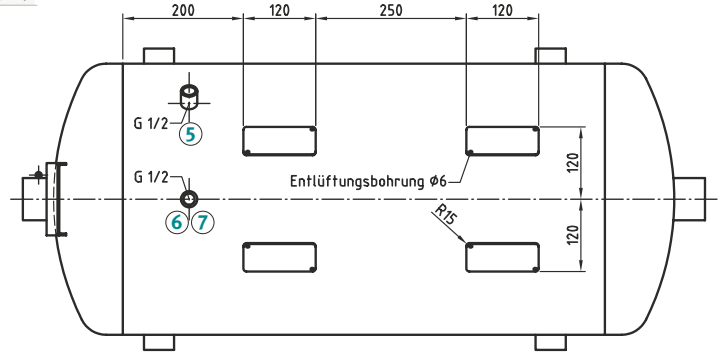
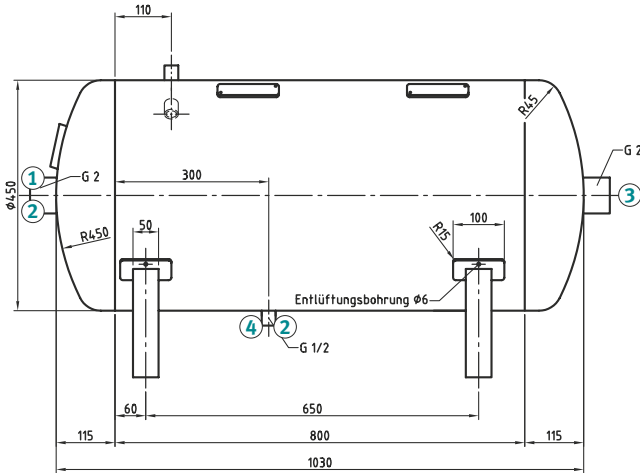

DB VZ 150/11 H / DB VZ 150/16 H

Fitting set, complete for DB VZ 150/11 H

For compressed air vessels		
Pressure	air vessels	Art. no.
11 bar	150 l flat	2500522
pieces	Type	
①	1 Reducing nipple R 2" (OT)-RP 1/2" (IT)	
②	2 Ball valve 1/2" IT/OT	
③	1 Dummy plug 2"	
④	1 Angle 90° 1/2" IT/OT	
⑤	1 Safety valve 1/2" 10 bar	
⑥	1 Reducing nipple R 1/2" (OT)-RP 1/4" (IT)	
⑦	1 Pressure gauge 1/4" 0-16 bar, upright	

Fitting set, complete for DB VZ 150/16 H

For compressed air vessels		
Pressure	air vessels	Art. no.
16 bar	150 l flat	2500523
pieces	Type	
①	1 Reducing nipple R 2" (OT)-RP 1/2" (IT)	
②	2 Ball valve 1/2" IT/OT	
③	1 Dummy plug 2"	
④	1 Angle 90° 1/2" IT/OT	
⑤	1 Safety valve 1/2" 15 bar	
⑥	1 Reducing nipple R 1/2" (OT)-RP 1/4" (IT)	
⑦	1 Pressure gauge 1/4" 0-25 bar, upright	

Horizontal type

Type	Pressure bar	Vessel capacity l	Manual/ Manhole	Weight kg	Art. no.
DB zinc plating 250/11 H	11	250	Recess	100	2500626
DB zinc plating 250/16 H	16	250	Recess	120	2500826

250 l flat

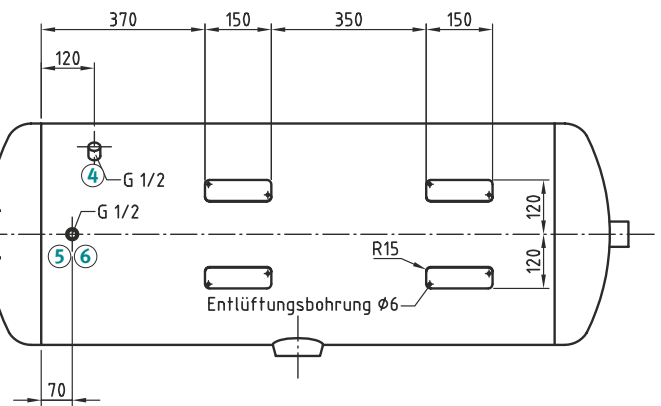
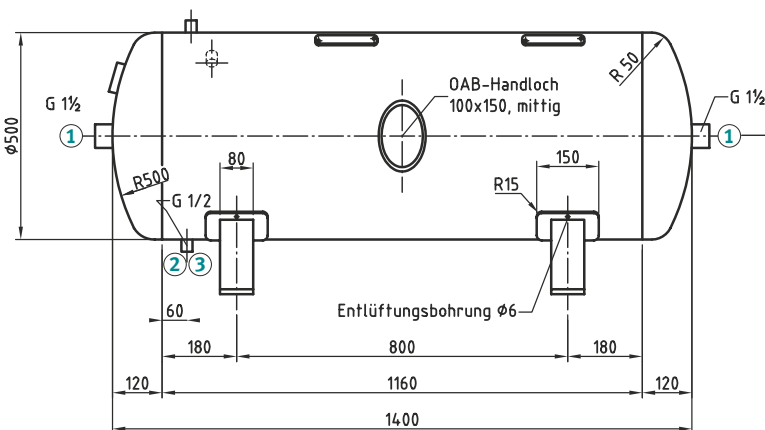

DB VZ 250/11 H / DB VZ 250/16 H

Fitting set, complete for DB VZ 250/11 H

For compressed air vessels		
Pressure	air vessels	Art. no.
11 bar	250 l flat	2500527
pieces	Type	
①	2 Ball valve 1 1/2" IT/OT	
②	1 Angle 90° 1/2" IT/OT	
③	1 Ball valve 1/2" IT/OT	
④	1 Safety valve 1/2" 10 bar	
⑤	1 Reducing nipple R 1/2" (OT)-RP 1/4" (IT)	
⑥	1 Pressure gauge 1/4" 0-16 bar, upright	

Fitting set, complete for DB VZ 250/16 H

For compressed air vessels		
Pressure	air vessels	Art. no.
16 bar	250 l flat	2500528
pieces	Type	
①	2 Ball valve 1 1/2" IT/OT	
②	1 Angle 90° 1/2" IT/OT	
③	1 Ball valve 1/2" IT/OT	
④	1 Safety valve 1/2" 15 bar	
⑤	1 Reducing nipple R 1/2" (OT)-RP 1/4" (IT)	
⑥	1 Pressure gauge 1/4" 0-25 bar, upright	

Horizontal type

500 l flat

Type	Pressure bar	Vessel capacity l	Manual/ Manhole	Weight kg	Art. no.
DB zinc plating 500/11 H	11	500	Recess	150	2500651
DB zinc plating 500/16 H	16	500	Recess	150	2500851

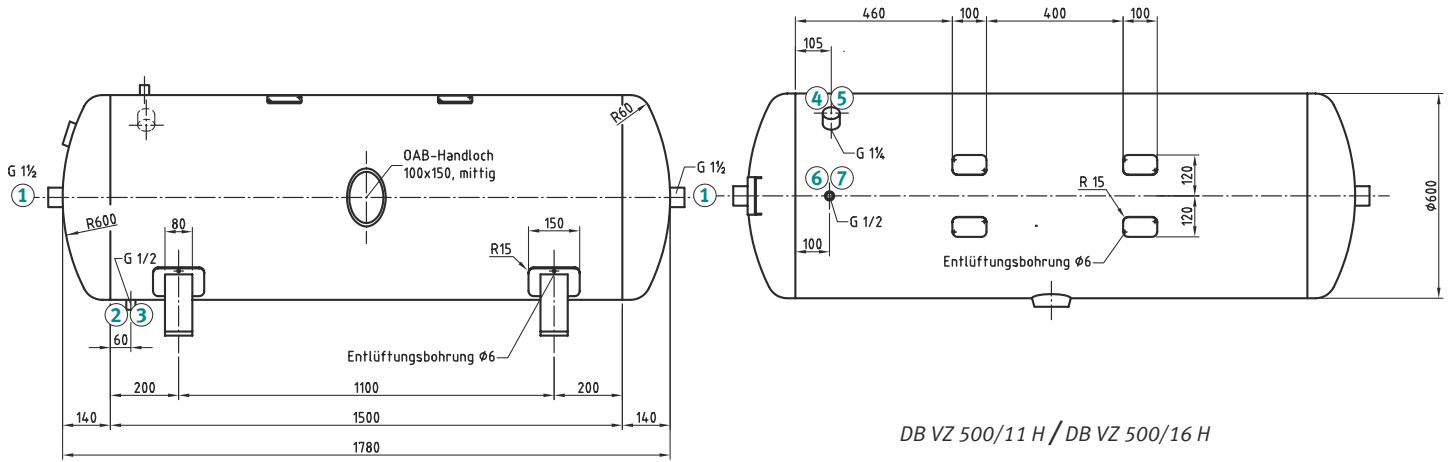

DB VZ 500/11 H / DB VZ 500/16 H

Fitting set, complete for DB VZ 500/11 H

Pressure	air vessels	Art. no.
11 bar	500 l flat	2500532

pieces	Type
①	2 Ball valve 1 1/2" IT/OT
②	1 Angle 90° 1/2" IT/OT
③	1 Ball valve 1/2" IT/OT
④	1 Reducing nipple R 1 1/4"(OT)-RP 1/2"(IT)
⑤	1 Safety valve 1/2" 10 bar
⑥	1 Reducing nipple R 1/2"(OT)-RP 1/4"(IT)
⑦	1 Pressure gauge 1/4" 0-16 bar, upright

Fitting set, complete for DB VZ 500/16 H

Pressure	air vessels	Art. no.
16 bar	500 l flat	2500533

pieces	Type
①	2 Ball valve 1 1/2" IT/OT
②	1 Angle 90° 1/2" IT/OT
③	1 Ball valve 1/2" IT/OT
④	1 Reducing nipple R 1 1/4"(OT)-RP 1/2"(IT)
⑤	1 Safety valve 1/2" 15 bar
⑥	1 Reducing nipple R 1/2"(OT)-RP 1/4"(IT)
⑦	1 Pressure gauge 1/4" 0-25 bar, upright

Horizontal type

750 l flat

Type	Pressure bar	Vessel capacity l	Manual/ Manhole	Weight kg	Art. no.
DB zinc plating 750/11 H	11	750	Recess	210	2500676
DB zinc plating 750/16 H	16	750	Recess	280	2500876

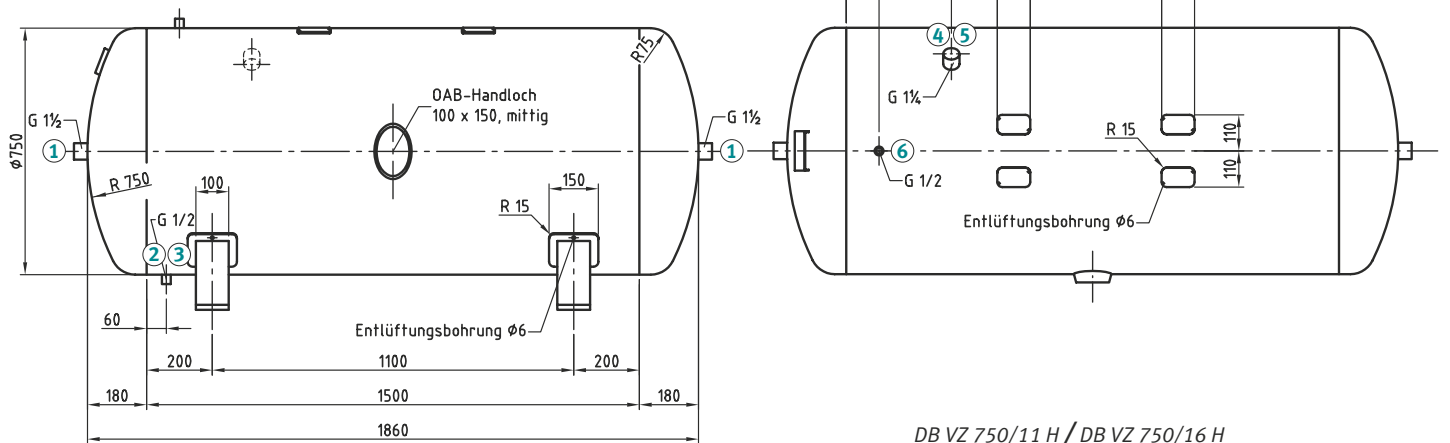

DB VZ 750/11 H / DB VZ 750/16 H

Fitting set, complete for DB VZ 750/11 H

Pressure	air vessels	Art. no.
11 bar	750 l flat	2500537

pieces	Type
①	2 Ball valve 1 1/2" IT/OT
②	1 Angle 90° 1/2" IT/OT
③	1 Ball valve 1/2" IT/OT
④	1 Reducing nipple R 1 1/4"(OT)-RP 1"(IT)
⑤	1 Safety valve 1" 10 bar
⑥	1 Pressure gauge 1/2" 0-16 bar, upright

Fitting set, complete for DB VZ 750/16 H

Pressure	air vessels	Art. no.
16 bar	750 l flat	2500538

pieces	Type
①	2 Ball valve 1 1/2" IT/OT
②	1 Angle 90° 1/2" IT/OT
③	1 Ball valve 1/2" IT/OT
④	1 Reducing nipple R 1 1/4"(OT)-RP 1"(IT)
⑤	1 Safety valve 1" 15 bar
⑥	1 Pressure gauge 1/2" 0-25 bar, upright

Components for compressed air systems

1,000 l flat

Horizontal type

Type	Pressure bar	Vessel capacity l	Manual/ Manhole	Weight kg	Art. no.
DB zinc plating 1000/11 H	11	1,000	2 x recess	300	2500681
DB zinc plating 1000/16 H	16	1,000	2 x recess	380	2500881

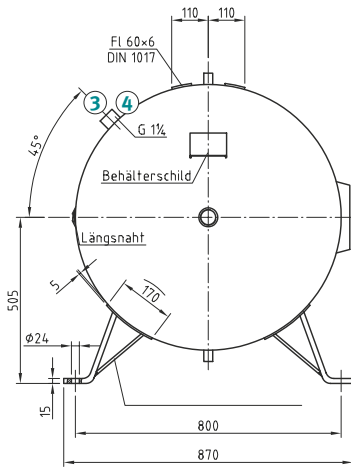
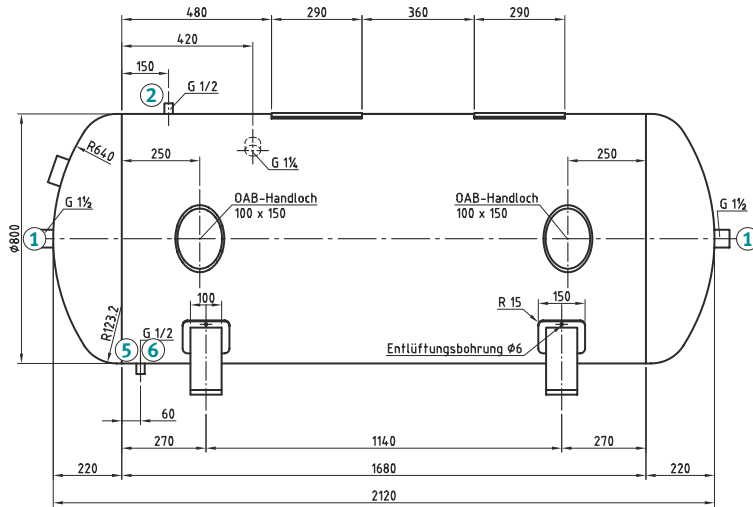

DB VZ 1000/11 H / DB VZ 1000/16 H

Fitting set, complete for DB VZ 1000/11 H

For compressed air vessels		
Pressure	Vessel capacity	Art. no.
11 bar	1,000 l flat	2500542
pieces	Type	
①	2 Ball valve 1 1/2" IT/OT	
②	1 Pressure gauge 1/2" 0-16 bar, upright	
③	1 Reducing nipple R 1 1/4"(OT)-RP 1"(IT)	
④	1 Safety valve 1" 10 bar	
⑤	1 Angle 90° 1/2" IT/OT	
⑥	1 Ball valve 1/2" IT/OT	

Fitting set, complete for DB VZ 1000/16 H

For compressed air vessels		
Pressure	Vessel capacity	Art. no.
16 bar	1,000 l flat	2500543
pieces	Type	
①	2 Ball valve 1 1/2" IT/OT	
②	1 Pressure gauge 1/2" 0-25 bar, upright	
③	1 Reducing nipple R 1 1/4"(OT)-RP 1"(IT)	
④	1 Safety valve 1" 15 bar	
⑤	1 Angle 90° 1/2" IT/OT	
⑥	1 Ball valve 1/2" IT/OT	

2,000 l flat

Horizontal type

Type	Pressure bar	Vessel capacity l	Manual/ Manhole	Weight kg	Art. no.
DB zinc plating 2000/11 H	11	2 000	2 x recess	480	2500701
DB zinc plating 2000/16 H	16	2 000	2 x recess	620	2500901

5,000 l flat

Horizontal type

Type	Pressure bar	Vessel capacity l	Manual/ Manhole	Weight kg	Art. no.
DB zinc plating 5000/11 H	11	5 000	Manhole	1 020	2500731
DB zinc plating 5000/16 H	16	5 000	Manhole	1 360	2500931

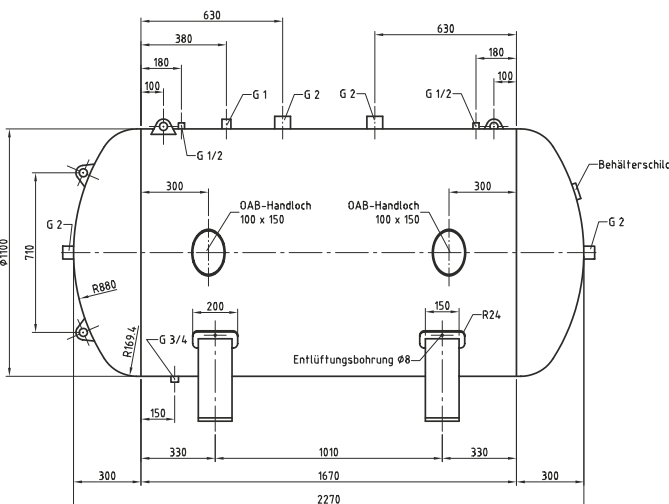

DB VZ 2000/11 H / DB VZ 2000/16 H

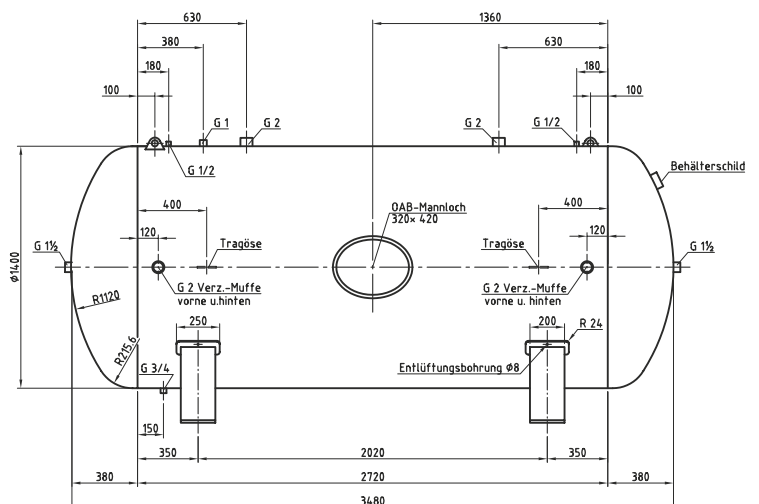

DB VZ 5000/11 H / DB VZ 5000/16 H

Compressed air energy savers - saves compressed air and energy

- ▶ Shuts off the compressed air vessel from the remaining air network at the end of the working day; this means that the compressed air content stays in the vessel
- ▶ Opens automatically at the preset shift start, and shuts-off at the end of the shift
- ▶ Multiple shifts can be configured daily – thanks to microprocessor control and 7 day timer program
- ▶ Slow 90° ball valve rotation in 30 seconds for G1, or 105 seconds for G2 avoids backlash on opening and closing
- ▶ With FPM seals and stainless steel balls
- ▶ Brass nickel-plated valve body
- ▶ 24 hour timer display
- ▶ Operating temperature: 0°C to 60°C
- ▶ Operating voltage: 115 V or 240 V AC/DC 50/60 Hz
- ▶ Power consumption: 7 W during cycle switch
- ▶ Max. temperature: 50°C ambient temperature, 100°C medium temperature
- ▶ Pressure range: 0 to 16 bar
- ▶ Protection class: IP 54



Energy saver G1

Energy saver G2

Type	Art. no.
Energy saver G1, connection: IT 1"	2150001
Energy saver G2, connection: IT 2"	2150003

Remote control option for Aircraft energy savers

- ▶ Matches Art. nos. 2100001 and 2150003



Type	Art. no.
Remote control with 5 m cable	2150002

Ball valves

- ▶ Suitable for compressed air with full free passage
- ▶ Temperature resistant from -20 °C to +180 °C



Type	Art. no.
R 3/8" IT	3/8" IT 2507710
R 3/8" IT	3/8" OT 2507711
R 1/2" IT	1/2" IT 2507712
R 1/2" IT	1/2" OT 2507714
R 3/4" IT	3/4" IT 2507715
R 3/4" IT	3/4" OT 2507716
R 1" IT	1" IT 2507720
R 1" IT	1" OT 2507721
R 1 1/4" IT	1 1/4" IT 2507725
R 1 1/4" IT	1 1/4" OT 2507726
R 1 1/2" IT	1 1/2" IT 2507730
R 1 1/2" IT	1 1/2" OT 2507731
R 2" IT	2" OT 2507741

Safety pallet SSP

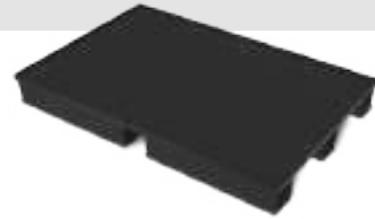

Type	Art. no.
1200 x 800 x 140 mm	2030103

Electromagnetic start-up relief 24 V AC



Type	Art. no.
normally closed	2506015
normally open	2506017

Noise-insulation for electromagnetic start-up relief

- ▶ Made of sintered bronze



Type	Art. no.
Sound absorber 3/8"	2255673M

Star-delta switch

- ▶ Ready for connection, fully wired in wall mounting cabinet
- ▶ Incl. connecting cable to air compressor
- ▶ Housing lockable, protection class IP 54
- ▶ With operating hour counter
- ▶ Operations on compressor only with with electromagnetic start-up relief, 24 V AC, normally closed, Art. no. 2506015



Type	Art. no.
Star-delta switch 400 Volt for 5.5 and 7.5 kW motors	2506010

AIRCRAFT Tandem control

- For time-delayed switching on and off of two compressors
- ▶ During maintenance of one compressor unit, the compressor can continue running with a single compressor unit
- ▶ Control principle: time delay setting, one overload relay per motor, one operating hours display per compressor, separate shutdown of the two compressors



Type	Art. no.
Tandem control	2506013

Components for compressed air systems

AIRCRAFT base load cyclic load control

- ▶ For controlling two compressors each with an output of 4.0 or 5.5 kW
- ▶ Cyclic changes of basic and peak-load compressor
- ▶ Two operating hour counters integrated
- ▶ Actual pressure value measured by pressure sensor 0 - 16 bar
- ▶ Adjustable motor circuit breaker
- ▶ Adjustable switch-on pressure
- ▶ Including control for relief valve 24 V DC (e.g., solenoid valve, Art no. 2506016, solenoid valves not included in scope of delivery)
- ▶ Includes connection option for safety switch (e.g., CONDOR MDR2, Art.no. 2506214, pressure vessel not included in scope of delivery)



Type	Art. no.
Base load cyclic load control	2506020

Pressure switch CONDOR

- ▶ Switch-off pressure configurable, incl. motor circuit breaker insert
- ▶ With 3-pole disconnecting on/off switch and start-up relief valve



Type	Art. no.
MDR 2/11 bar, pressure vessel connection 3/8", 3 x 1/4" horizontal with AEV2S relief valve	2506214
MDR 4/16/8-16 bar, incl. relief valve, 4 x 1/4" connection, preset to 7.8 to 9.8 bar, adjustable up to 16 bar at 400 V Max 16 amp.	2506300
MDR 3/11 bar / 4-6.3 Amp., connections 3 x 1/4" horizontal, 1 x 3/8" vertical incl. relief valve	2506303
MDR 3/11 bar / 6.3-10 Amp., connections 3 x 1/4" horizontal, 1 x 3/8" vertical incl. relief valve	2506304
MDR 3/11 bar / 10-16 Amp., connections 3 x 1/4" horizontal, 1 x 3/8" vertical incl. relief valve	2506305
MRD 3/16 bar / 10-16 Amp., connections 3 x 1/4" horizontal, 1 x 3/8" vertical incl. relief valve	2506307

Hood with operating hour counter for pressure switch



Type	Art. no.
matches CONDOR MDR 3 model	2506301

Motor protection switch



Type	Art. no.
Motor circuit breaker 2-phase, 4 Amp.	2506504
Motor circuit breaker 2-phase, 7 Amp.	2506507
Motor circuit breaker 2-phase, 10 Amp.	2506510
Motor circuit breaker 1-phase, 10 Amp.	2506610
Motor circuit breaker 1-phase, 12 Amp.	2506612
Motor circuit breaker 1-phase, 14 Amp.	2506614

Pressure gauge



Type	Art. no.
Ø 40 mm, 1/8" rear, 10 bar	2506440
Ø 50 mm, 1/8" side, 10 bar	2506451
Ø 50 mm, 1/4" side, 10 bar	2506452
Ø 50 mm, 1/4" rear, 16 bar	2506450
Ø 63 mm, 1/4" rear, 10 bar	2506460
Ø 63 mm, 1/4" rear, 15 bar	2506465

Safety valve category IV CE 97/23



Type	Art. no.
10 bar 1/4" OT, 1170 NI/min	2507210
13 bar 1/4" OT, 3070 NI/min	2507213
15 bar 1/4" OT, 4400 NI/min	2507215
10 bar 3/8" OT, 3050 NI/min	2507121
15 bar 3/8" OT, 4400 NI/min	2507124
10 bar 1/2" OT, 3970 NI/min	2507126
15 bar 1/2" OT, 5790 NI/min	2507127
10 bar 3/4" OT, 10900 NI/min	2507128
15 bar 3/4" OT, 24850 NI/min	2507129

Condensate drain valve



Type	Art. no.
1/4"	2507307
3/8"	2507310

Non-return valves with connection for 6 mm relief line



Type	Art. no.
RS valve 1/2" OT x 3/8" OT	2507510
RS valve 1/2" OT x 1/2" OT	2507512
RS valve 3/4" OT x 3/4" OT	2507516

Push-in connector for 8 mm line



Connection	Design	Bar max.	Art. no.
1/8" OT x 8 mm	straight	15	2251220188
2 x 8 mm	straight	15	225135008
2 x 8 mm	Angle	16	225748008
① 3/8" OT x 8 mm	Angle	16	22577540388
② 1/4" OT x 8 mm	straight	16	2257440148
③ 3 x 8 mm	T-piece	16	225749008

Push-in connector for 6 mm line



Connection	Design	Bar max.	Art. no.
① 1/8" OT x 6 mm	straight	15	2251220186
② 1/8" OT x 6 mm	Angle	15	2251250186
1/4" OT x 6 mm	straight	16	2257440146

Push-in connector for 4 mm line



Connection	Design	Bar max.	Art. no.
① 1/8" OT x 4 mm	straight	16	2258450184
M5 OT x 4 mm	Angle	15	2251250054
② M5 OT x 4 mm	T-piece	15	2251310054
M5 OT x 4 mm	straight	16	2258450054

Polyamide lines

Bulk



Type	Art. no.
Ø 4 mm external, max. 44 bar	22525909
Ø 6 mm external, max. 27 bar	22525911
Ø 8 mm external, max. 19 bar	22525912

Armoured hoses

- For connecting compressors to compressed air vessels or piping systems
- One connection each with inside and outside thread



IT/OT	Length	Operating pressure	Art. no.
3/8"	400 mm	15 bar	2507610
3/8"	570 mm	15 bar	2507612
1/2"	500 mm	15 bar	2507615
1/2"	1500 mm	15 bar	2507617
3/4"	550 mm	15 bar	2507621
3/4"	630 mm	15 bar	2507622
3/4"	800 mm	15 bar	2507624
3/4"	1500 mm	15 bar	2507625
1"	1500 mm	40 bar	2500195
1 1/4"	1500 mm	45 bar	2500196
1 1/2"	1500 mm	40 bar	2500199

Screw lock

- Medium tight for gap 0.05 - 0.25



Type	PQ	Art. no.
Screw lock 10 g	10	2500022
Screw lock 50 g	1	2500023
Screw lock 250 g	1	2500024

Running wheels



Type	Art. no.
① Steering roller with metal brake	2505562
Wheel axle L: 460 mm for 50 l pressure vessel	2500966
Wheel axle L: 495 mm for 100 l pressure vessel	2500967
Wheel axle L: 675 mm for 200 l pressure vessel	2500968
Star lock cap for wheel axle Ø 20 mm	2505505
② PU foam wheel diameter 260 x 20 mm, puncture-proof	2505629

Rubber anti-vibration elements for installation under pressure vessels, power units, etc.



Type	Art. no.
SE 1 - 120 x 32 x 100 mm / M 12	3381012
SE 2 - 100x38 mm/M10	2505640
with single-sided thread	
SE 3 - 70 x 38 mm / 2 x M10,	2505650
with two-sided thread	
SE 4 - 30 x 20 mm / 2 x M8,	2505630
with two-sided thread	

Safety grille metal

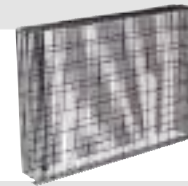

Type	Art. no.
570 x 780 mm, for stationary models as of model year 2009	2501211
380 x 600 mm for 50 l pressure vessels as of model year 2009	2501215
470 x 730 mm for 100 l pressure vessels as of model year 2009	2501218

Oils



Special oil RoOil Simco 32 E

for Airboy Silence 50 Pro
0.5 l bottle 2500016

Special oil RSX 100

for Rotal piston compressors
1 l bottle 2500017

Mineral oil 20W-30

piston compressors
1 l bottle 2500012
5 l Canister 2500015

Semi-synthetic oil Rot-Energy-Plus, 46 cSt

for screw-type compressors
3.75 l Canister 0600000018A
18.5 l Canister 0600000007A
4 pcs. 3.75 l canister 0600000009A
210 l barrel 0600000012A

Air filter cartridge

Type	Art. no.
Air filter cartridge	0017083000
Air filter cartridge	0017092000
Air filter cartridge	0017093000
Air filter cartridge	0017101000



Components for compressed air systems

Components

V-belt pulley



Type	Art. no.
A 110 x 24	02504100
SPZ 110 x 28	02504112
A 120 x 24	02504120
SPZ 120 x 28	02504122
SPB 130 x 28	02504131
SPB 160 x 28	02504161
A 140 x 24	02504140
SPZ 170 x 28	02504172
SPB 180 x 28	02504181
SPB 200 x 28	02504201
A 180 x 28 dual-groove	02505180

Toothed v-belt



Type for models up to MY 08/2009	Art. no.
AX 53	02505353
AX 60	02505360
AX 62	02505362
AX 70	02505370
Type for models as of MY 08/2009	Art. no.
AX 43	02505208
AX 45.5	02505210
AX 50	02505214
XPB 1900	02505218
XPZ 1500	02505221
XPZ 1600	02505224

Wear parts for compressors

Compressor	Wear part	Art. no.
MK 102	Valve plate	0250130217
MK 102	Air filter cartridge	0250130219
MK 102	Seal kit	0250130224
MK 103	Valve plate	0250130317
MK 103	Air filters	0250131231
MK 103	Seal kit	0250130324
MK 113	Valve plate	0250131228
MK 113	Air filters	0250131231
MK 113	Seal kit	0250131239
MK 102 MK 103 MK 113	Start-up relief valve 1/4" 2.2 bar	0250130221
BK 119	Valve plate	0250131925
BK 119	Air filter cartridge Ø 65 mm	0250131928
BK 119	Seal kit	0250131940
BK 120	Valve plate	0250132042
BK 120	Air filter cartridge	0250132163E
BK 120	Seal kit	0250132164
BK 119, 120	Safety valve 1/4" 16.5 bar	0250131931
BK 119, 120	Safety valve 1/4" 6 bar	0250131934
VKM 362 3M	Valve plate	0250140006
VKM 362 3M	Seal kit	0250133062
VKM 362 3M	Air filter cartridge	0250134013
VKM 320 3M oil-free	Valve plate	0413175002
VKM 320 3M oil-free	Seal kit	0250134029
VKM 320 3M oil-free	Air filter cartridge	0250134013

Motors



Type	Art. no.
1.5 kW/230 V with motor protection 12A, 1Ph.	02502151
1.8 kW/230 V with motor protection 12A, 1Ph.	02502181
1.8 kW/400 V with motor protection 4A, 2Ph.	02502183
2.2 kW/230 V with motor protection 16A, 1Ph.	02502221
2.2 kW/ 400 V	02502222
3.0 kW/ 400 V	02502302
4.0 kW / 400 V	02502402
5.5 kW/ 400 V	02502553
7.5 kW/ 400 V	02502753
11 kW/ 400 V	02502853

Oil-lubricated coaxial compressor units

- ▶ Coaxial compressors use a work system that Fini has made popular worldwide, known as the "coaxial drive". The crankshaft and drive shaft are a single component, this means:
- ▶ Maximum mechanical efficiency
- ▶ Does not need any further drive components
- ▶ Fewer moving parts

Main features:

- ▶ Ultra-efficient cooling air guidance
- ▶ Special, stainless steel ground valves. Oil-lubricated and oil-free models are available from 0.6 to 3 kW, and with 2 or 4 way, 8 bar, single or twin-cylinder

OIL LUBRICATED	2 WAY 8-10 BAR						4 WAY				
	MK 2400 8 bar	SF 2500 8 bar	VKM 4020 10 bar	MK 265	MK 285	MK 312	VKM 402	MK 97 15 bar	MK 137 8 bar	VKM 362 10 bar	VKM 592 10 bar
Aftercoolers	-	-	✓	✓	✓	✓	✓	-	-	✓	✓
Overload protection	-	✓	✓	✓	✓	✓	✓	✓	✓	✓	✓
Premium rod end bearings	-	-	-	-	-	-	✓	-	-	✓	✓
Cast iron cylinder	✓	✓	✓	✓	✓	✓	-	✓	✓	✓	✓
Aluminium cylinder	-	-	-	-	-	-	✓	-	-	-	-



MK 2400 - 2M



SF 2500 - 2M



VKM 4020 - 3M



MK 137 - 1M

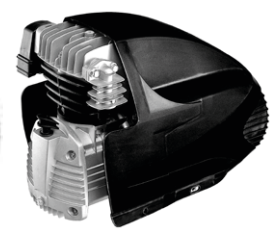

MK 265-285



VKM 362-402



VKM 592 - 4



MK 312 - 3M



MK 236 - 4S HONDA

Type	Maximum pressure	Number of cylinders	Motor output	Intake capacity	Speed	Voltage/phases	Weight	Art. no.
Single-phase oil lubricated								
MK 97/15 - 0.75M	15 bar	1	0.55 kW	87 l/min.	1 420 rpm	230 V / 1	12.8 kg	2501370
MK 137 - 1M	8 bar	1	0.74 kW	108 l/min.	1 420 rpm	230 V / 1	12.8 kg	2501313
MK 2400 - 2M	8 bar	1	1.5 kW	179 l/min.	2 850 rpm	230 V / 1	11 kg	2501420
SF 2500 - 2M	8 bar	1	1.5 kW	185 l/min.	2 850 rpm	230 V / 1	10.7 kg	2501391
MK 265 - 2M	10 bar	1	1.5 kW	250 l/min.	2 850 rpm	230 V / 1	13.3 kg	2501411
MK 285 - 2.5M	10 bar	1	1.8 kW	260 l/min.	2 850 rpm	230 V / 1	14.5 kg	2501381
MK 285 Pulsar - 2.5M	10 bar	1	1.8 kW	260 l/min.	2 850 rpm	230 V / 1	14.5 kg	2501315
MK 312 - 3M	10 bar	1	2.2 kW	284 l/min.	2 850 rpm	230 V / 1	16.5 kg	2501317
VKM 362 - 3M	10 bar	2 V	2.2 kW	310 l/min.	1 420 rpm	230 V / 1	23.6 kg	2501330
VKM 402 - 3M	10 bar	2 V	2.2 kW	400 l/min.	2 850 rpm	230 V / 1	21.5 kg	2501440
VKM 4020 - 3M	10 bar	2 V	2.2 kW	356 l/min.	2 850 rpm	230 V / 1	20.5 kg	2501335
VKM 592 - 4M	10 bar	2 V	3 kW	590 l/min.	1 420 rpm	230 V / 1	45.5 kg	2501350
Three-phase oil lubricated								
MK 265 - 2	10 bar	1	1.5 kW	250 l/min.	2 850 rpm	400 V/3	14.5 kg	2501309
VKM 362 - 3	10 bar	2 V	2.2 kW	310 l/min.	1 420 rpm	230-400 V/3	21.5 kg	2501332
VKM 402 - 3	10 bar	2 V	2.2 kW	400 l/min.	2 850 rpm	230-400 V/3	19.5 kg	2501333
VKM 592 - 4	10 bar	2 V	3 kW	590 l/min.	1 420 rpm	230-400 V/3	45.5 kg	2501334
Oil-lubricated with petrol engine								
MK 236 - 4S HONDA	10 bar	1	3 kW	235 l/min.	3 420 rpm	230-400 V/3	12.5 kg	2501318

Power units

Oil-free oil-lubricated coaxial compressor units

- ▶ Directly driven compressor units from 1.1 to 2.2 kW and 2 to 4 way, 8 and 10 bar, single or twin cylinder
- ▶ Self-lubricating, non-toxic and approved materials allow for the use of these compressors in medical applications, and in the dental industry
- ▶ Unique compressor motor crankshaft
- ▶ Maximum mechanical efficiency
- ▶ No transmission elements
- ▶ High-efficiency cooling air fan
- ▶ Fin valves for optimum efficiency
- ▶ Front and additional cooling for maximum durability
- ▶ Anti-corrosive surface treatment

OIL-FREE	2 WAY – 8 BAR			4 WAY – 10 BAR		
	OL 1850	OL 232	OL 55 OL 75	MK 160	VKM 320	
Aftercoolers	-	✓	-	✓	✓	
Overload protection	✓	✓	-	✓	✓	
Premium rod end bearings	✓	✓	✓	✓	✓	
Twin pistons	✓	✓	✓	-	-	



OL 1850



OL 232



OL 55 - 75



MK 160



VKM 320

Type	Maximum pressure	Number of cylinders	Motor output	Intake capacity	Speed	Voltage/phases	Weight	Art. no.
Single-phase oil-free								
OL 55 - 0.75M	8 bar	1	0.55 kW	118 l/min.	1 420 rpm	230 V /1	10 kg	2501395
OL 75 - 1M	8 bar	1	0.75 kW	155 l/min.	1 420 rpm	230 V /1	11 kg	2501396
OL 1850 - 1.5M	8 bar	1	1.1 kW	179 l/min.	2 850 rpm	230 V /1	7 kg	2501361
OL 232 - 2M	8 bar	1	1.5 kW	218 l/min.	2 850 rpm	230 V /1	11 kg	2501397
MK 160 - 1.5M	10 bar	1	1.1 kW	152 l/min.	1 420 rpm	230 V /1	14.5 kg	2501314
VKM 320 - 3M	10 bar	2 V	2.2 kW	320 l/min.	1 420 rpm	230 V /1	20 kg	2501340
VKM 320 - 3	10 bar	2 V	2.2 kW	320 l/min.	1 420 rpm	230-400 V/3	20 kg	2501331

Oil-lubricated, V-belt driven compressor units

- ▶ Cylinders and cylinder heads with long ribs for optimum heat dissipation;
- ▶ carefully balanced cast iron crankshaft for smoother action
- ▶ Stainless steel valves with high air flow rate
- ▶ Pulley designed as fan
- ▶ Optimised air flow, high fan performance
- ▶ High-efficiency air filter with labyrinth intake duct to reduce noise
- ▶ The models listed below are available in the following designs:
 - ▶ Single stage from 1.1 to 4 kW
 - ▶ Two-stage from 3 to 7.5 kW
 - ▶ V-shape and two-stage, from 4 to 15 kW

OIL LUBRICATED	SINGLE STAGE					TWO STAGE				
	MK 102/N	MK 102	MK 103	MK 113	BK 113	BK 114	BK 119	BK 120	BKV 30	BKV 50
Aftercoolers	-	✓	✓	✓	✓	✓	✓	✓	✓	✓
Intermediate cooler	-	-	-	-	✓	✓	✓	✓	✓	✓
Air intake duct	-	✓	✓	✓	✓	✓	✓	✓	-	-
External ventilation	✓	✓	✓	✓	✓	✓	✓	✓	✓	✓
Cast iron cylinder	✓	✓	✓	✓	✓	✓	✓	✓	✓	✓
Start-up relief valve	-	✓	✓	✓	-	-	-	-	-	-



MK 102/N



MK 102



MK 113



BK 120



BKV 50

Type	Maximum pressure	Number of cylinders	Motor output	Intake capacity	Speed	Voltage/phases	Weight	Art. no.
Single stage								
MK 102/N	10 bar	2	1.5 kW	215 l/min.	1 375 rpm	-	9 kg	2501304
MK 102	10 bar	2	1.5 kW	235 l/min.	1 040 rpm	-	9 kg	2501302
MK 103	10 bar	2	2.2 kW	365 l/min.	1 370 rpm	-	9.5 kg	2501303
MK 113	10 bar	2	4 kW	556 l/min.	1300 rpm	-	18.3 kg	2501312
Two stage								
BK 113	10 bar	2	3 kW	430 l/min.	1 310 rpm	-	19.6 kg	2501323
BK 113-28 bar	28 bar	2	2.2 kW	225 l/min.	680 rpm	-	16 kg	2501324
BK 114	10 bar	2	4 kW	585 l/min.	1 370 rpm	-	32.5 kg	2501325
BK 119	10 bar	2	5.5 kW	840 l/min.	1 250 rpm	-	34 kg	2501319
BK 120	10 bar	2	7.5 kW	1 080 l/min.	1 000 rpm	-	54.3 kg	2501321
BKV 30	11 bar	4 V	11 kW	1 745 l/min.	1 200 rpm	-	100 kg	2501130
BKV 50	11 bar	4 V	15 kW	2 148 l/min.	1 050 rpm	-	152 kg	2501150

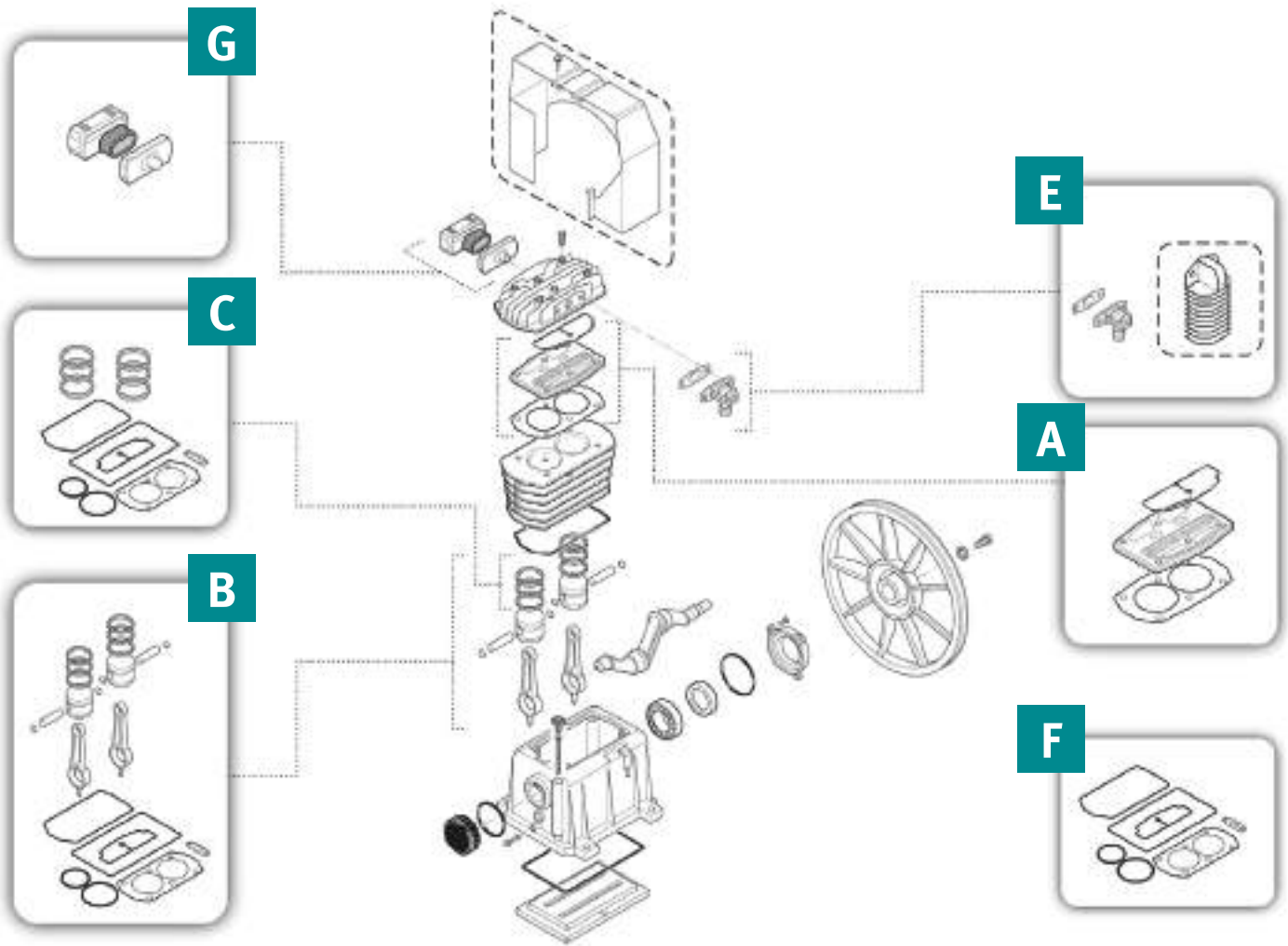

Single-stage units



		KIT A	KIT B	KIT C	KIT E	KIT F	KIT G	Oil
	Commodity group	• Complete valve plate	• Conrod piston	• Piston rings	• Aftercooler	• Complete sealing set	• Air filters	• Max. oil fill
MK 102/N	0200F	09434A00	09434B00	09434C00	–	09434F00	04105291	0.5
MK 102	0200F	09434A00	09434B01	09434C01	09434E01	09434F00	04105291	0.5
MK 103	0200F	09434A01	09434B02	09434C02	09434E02	09434F01	04105290	0.5
MK 113	0200F	09434A02	09434B03	09434C03	09434E03	09434F02	04105290	0.9

Designation	Art. no.
Valve plate KIT A (MK 102 N / MK 102)	09434A00
Valve plate KIT A (MK 103)	09434A01
Valve plate KIT A (MK 113)	09434A02
Conrod piston KIT B (MK 102/N)	09434B00
Conrod piston KIT B (MK 102)	09434B01
Conrod piston KIT B (MK 103)	09434B02
Conrod piston KIT B (MK 113)	09434B03
Piston rings KIT C MK 102/N KIT C	09434C00
Piston rings KIT C (MK 102)	09434C01
Piston rings KIT C (MK 103)	09434C02
Piston rings KIT C (MK 113)	09434C03

Designation	Art. no.
Aftercooler KIT E (MK 102)	09434E01
Aftercooler KIT E (MK 103)	09434E02
Aftercooler KIT E (MK 113)	09434E03
Compl. sealing set KIT F (MK 102/N)	09434F00
Compl. sealing set KIT F (MK 102)	09434F00
Compl. sealing set KIT F (MK 103)	09434F01
Compl. sealing set KIT F (MK 113)	09434F02
Air filter KIT G (MK 102 / MK 102/N)	04105291
Air filter KIT G (MK 103 / MK 113)	04105290

For correct maintenance of the compressor, we recommended changing the oil at least once a year using our lubricants.

Oils	Art. no.
Special oil RoOil Simco 32 E for Airboy Silence 50 Pro	
0.5 l bottle	2500016
Special oil RSX 100 for Rotal piston compressors	
1 l bottle	2500017

Oils	Art. no.
Mineral oil 20W-30 piston compressors	
1 l bottle	2500012
5 l Canister	2500015



Maintenance kits for piston compressors

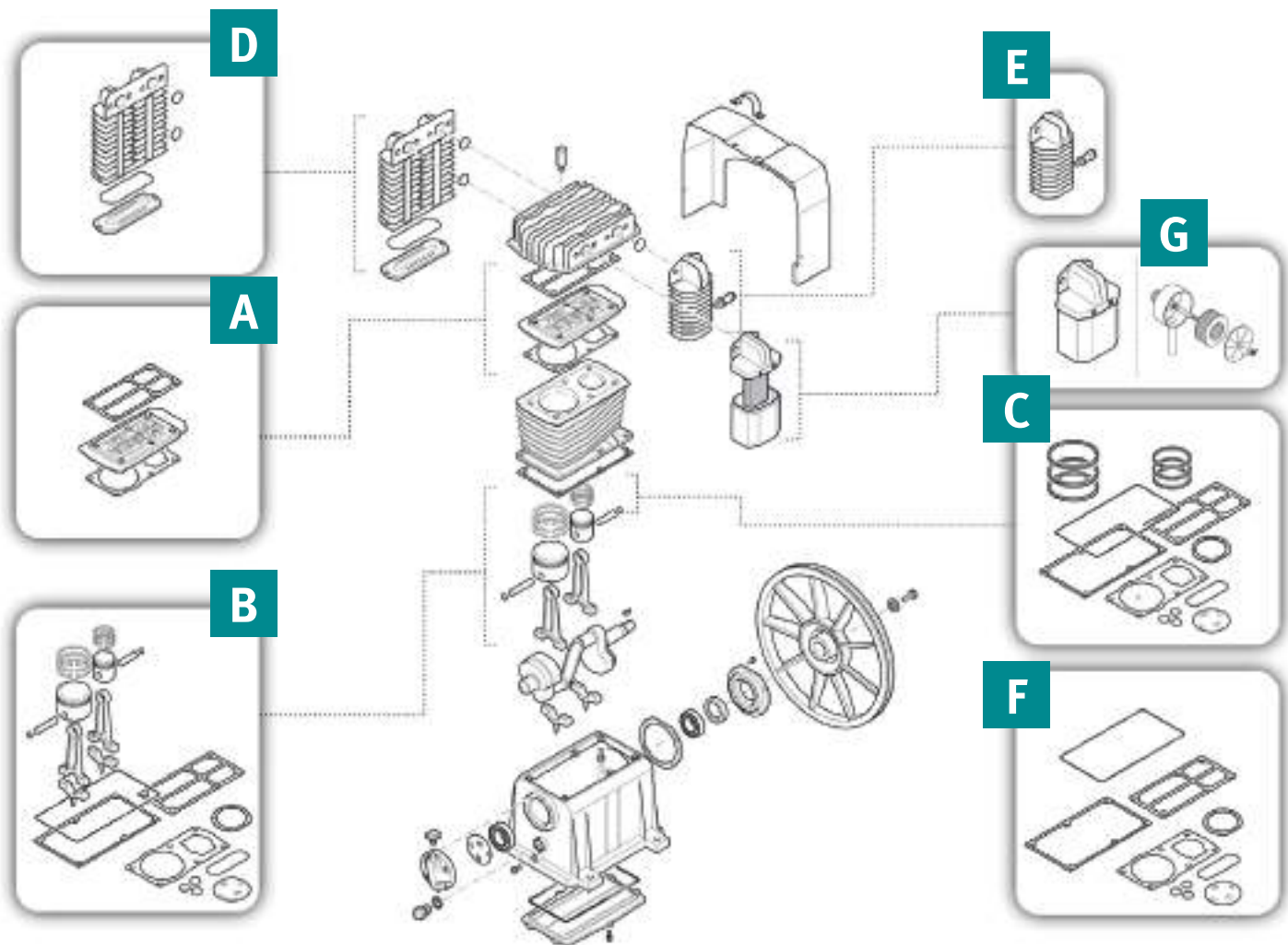

Two-stage unit



		KIT A	KIT B	KIT C	KIT D	KIT E	KIT F	KIT G		Oil
	Commodity group	• Complete valve plate	• Conrod piston	• Piston rings	• Intermediate cooler	• Aftercooler	• Complete sealing set	• round	• rectangular	• Max. oil fill
BK 113	0200F	09434A03	09434B04	09434C04	09434D00	09434E03	09434F03	–	0317072000	0.7
BK 114	0200F	09434A04	09434B05	09434C05	09434D00	09434E04	09434F04	–	0317071000	0.9
BK 119	0200F	09434A04	09434B06	09434C06	09434D00	09434E05	09434F05	–	0317071000	1.34
BK 120	0200F	09434A05	09434B07	09434C07	09434D01	09434E06	09434F06	0317011000	–	1.52

Designation	Art. no.
Complete valve plate KIT A (BK 113)	09434A03
Complete valve plate KIT A (BK 114)	09434A04
Complete valve plate KIT A (BK 119)	09434A04
Complete valve plate KIT A (BK 120)	09434A05
Conrod piston KIT B (BK 113)	09434B04
Conrod piston KIT B (BK 114)	09434B05
Conrod piston KIT B (BK 119)	09434B06
Conrod piston KIT B (BK 120)	09434B07
Piston rings KIT C (BK 113)	09434C04
Piston rings KIT C (BK 114)	09434C05
Piston rings KIT C (BK 119)	09434C06
Piston rings KIT C (BK 120)	09434C07
Intermediate cooler KIT D (BK 113)	09434D00
Intermediate cooler KIT D (BK 114)	09434D00

Designation	Art. no.
Intermediate cooler KIT D (BK 119)	09434D01
Aftercooler KIT E (BK 113)	09434E03
Aftercooler KIT E (BK 114)	09434E04
Aftercooler KIT E (BK 119)	09434E05
Aftercooler KIT E (BK 120)	09434E06
Complete sealing set KIT F (BK 113)	09434F03
Complete sealing set KIT F (BK 114)	09434F04
Complete sealing set KIT F (BK 119)	09434F05
Complete sealing set KIT F (BK 120)	09434F06
Air filter rectangular KIT G (BK 113)	0317072000
Air filter rectangular KIT G (BK 119/BK 114)	0317071000
Air filter round KIT G (BK 120)	0317011000

For correct maintenance of the compressor, we recommended changing the oil at least once a year using our lubricants.

Oils	Art. no.
Special oil RolOil Simco 32 E for Airboy Silence 50 Pro	
0.5 l bottle	2500016
Special oil RSX 100 for Rotal piston compressors	
1 l bottle	2500017

Oils	Art. no.
Mineral oil 20W-30 piston compressors	
1 l bottle	2500012
5 l Canister	2500015



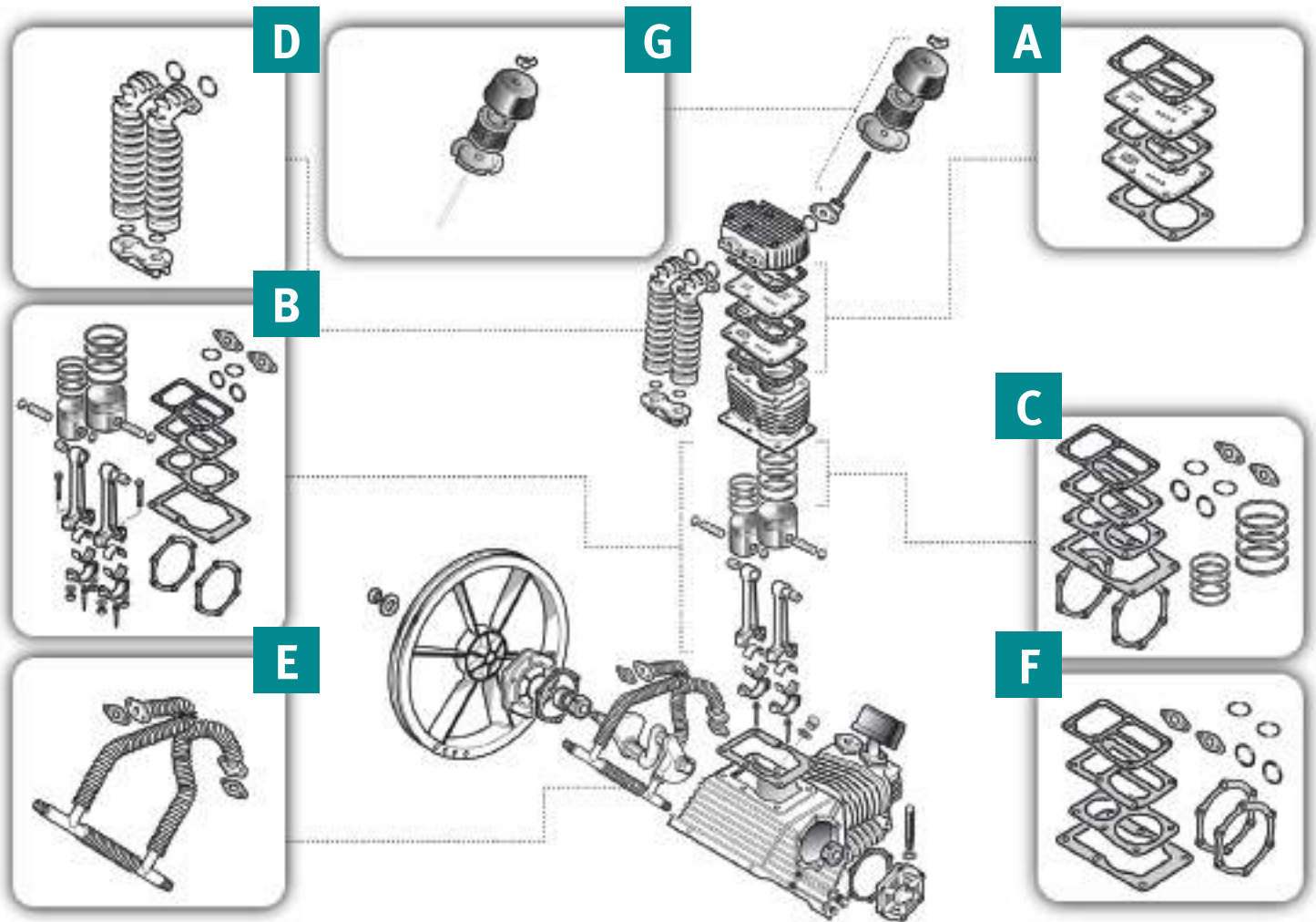

Two-stage unit with "V" cylinders



	Commodity group	KIT A		KIT B		KIT C	KIT D	KIT E	KIT F	KIT G	Oil
		• SX L	• DX R	• SX L	• DX R						
		• Complete valve plate		• Conrod piston		• Piston rings	• Intermediate cooler	• Aftercooler	• Complete sealing set	• round	• Max. oil fill
BKV 30	0200F	09434A16	09434A23	09434B20	09434B27	09434C19	09434D03	09434E12	09434F17	OSP81000	3.1
BKV 50	0200F	09434A17	09434A24	09434B21	09434B21	09434C20	09434D04	09434E18	09434F18	OSP81000	6.67

Designation	Art. no.
Compl. valve plate (SX L) KIT A (BKV 30)	09434A16
Compl. valve plate (SX L) KIT A (BKV 50)	09434A17
Compl. valve plate (DX R) KIT A (BKV 30)	09434A23
Compl. valve plate (DX R) KIT A (BKV 50)	09434A24
Conrod piston (SX L) KIT B (BKV 30)	09434B20
Conrod piston (SX L) KIT B (BKV 50)	09434B21
Conrod piston (DX R) KIT B (BKV 30)	09434B27
Conrod piston (DX R) KIT B (BKV 50)	09434B21
Piston rings KIT C (BKV 30)	09434C19

Designation	Art. no.
Piston rings KIT C (BKV 50)	09434C20
Intermediate cooler KIT D (BKV 30)	09434D03
Intermediate cooler KIT D (BKV 50)	09434D04
Aftercooler (BKV 30)	09434E12
Aftercooler (BKV 50)	09434E18
Complete sealing set (BKV 30)	09434F17
Complete sealing set (BKV 50)	09434F18
Air filter round KIT G (BKV 30)	OSP81000
Air filter round KIT G (BKV 50)	OSP81000

For correct maintenance of the compressor, we recommended changing the oil at least once a year using our lubricants.

Oils	Art. no.
Special oil RoOil Simco 32 E for Airboy Silence 50 Pro	
0.5 l bottle	2500016
Special oil RSX 100 for Rotal piston compressors	
1 l bottle	2500017

Oils	Art. no.
Mineral oil 20W-30 piston compressors	
1 l bottle	2500012
5 l Canister	2500015



Compressed air quality classes as per DIN ISO 8573

The compressed air quality classes according to DIN ISO 8573-1 make it easier for users to define their requirements and select conditioning components. The standard is based on the manufacturer's specifications, which define permissible limits with respect to compressed air purity for plant and machinery.

The DIN ISO 8573-1 standard defines the classes of the air quality in terms of:

Oil content

Specification of the residual aerosols and hydrocarbons which may be present in the compressed air.

Particle size and density

Specification of the size and concentration of solid particles which may be contained in the compressed air.

Pressure dew point

Specification of the temperature to which it is possible to cool the compressed air without the water vapour contained in it condensing.

The pressure dew point varies with the air pressure.

Class	Particles (dirt)		Water (condensate)		Oil
	Particle size in μm , max.	Particle density in mg/m^3 , max.	Pressure dew point in $^{\circ}\text{C}$	The level of water in g/m^3	Residual oil content in mg/m^3
0	< 0.1	< 0.1	< -70 $^{\circ}\text{C}$	< 0.003	< 0.01
1	0.1	0.1	-70 $^{\circ}\text{C}$	0.003	0.01
2	1	1	-40 $^{\circ}\text{C}$	0.11	0.1
3	5	5	-20 $^{\circ}\text{C}$	0.88	1
4	15	15	+3 $^{\circ}\text{C}$	6	5
5	40	40	+7 $^{\circ}\text{C}$	7.8	25
6	> 40	> 40	+10 $^{\circ}\text{C}$	9.4	> 25
7	-	-	> +10 $^{\circ}\text{C}$	> 9.4	-



AIRCRAFT air filters and water traps

Compressed air filters are used for highly efficient removal of solid particles, water, oil, aerosols, hydrocarbons, odours and vapours from compressed air systems.

In order to achieve the required quality of compressed air, filters that remove all types of solid and liquid contaminants from the compressed air in various stages, are installed in the compressed air line.

Your benefits thanks to improve compressed air quality:

- ▶ Reliable filtration of liquids such as water and aerosols as well as particles, dust and gases
- ▶ Better working and production conditions
- ▶ Optimum protection of connected equipment and tools
- ▶ Improved product quality due to substantial decrease in rejects
- ▶ Protects the compressed air system against contamination
- ▶ Increased productivity by reducing maintenance



Degrees of filtration

1

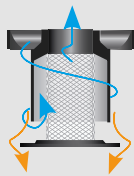

Water separator

2

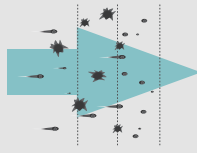

Pre-filters/Microfilters

3

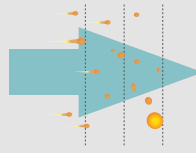

Micro filter

4

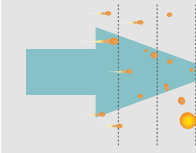

Nanofilters

5



Activated carbon filter element

Designation

Characteristic values

Filtration type

Application

Particles
Oil

	Water separator	Pre-filters/Microfilters	Micro filter	Nanofilters	Activated carbon filter element
	> 98% Deposition (drops)	< 1 µm Solid matter contamination	< 0.1 µm Solid matter contamination < 0.1 mg/m³ Residual aerosol content	< 0.01 µm Solid matter contamination < 0.01 mg/m³ Residual aerosol content	0.005 mg/m³ Residual aerosol content
	Water separation	Wet and dry filtration	Wet and dry filtration	Wet and dry filtration	Oil vapour adsorption
	Removal of larger amounts of liquids, e.g., downstream of coolers	Removal of moderate amounts of fine solid or liquid contaminants such as finer dust, smaller droplets and aerosols	Removal of small amounts of microscopic solid or liquid contaminants such as micro-dusts, oil mist, aerosols In case of an occurrence of dirt in conjunction with an upstream coarse or microfilter	Removal of small amounts of microscopic solid or liquid contaminants such as micro-dusts, oil mist, aerosols In case of an occurrence of dirt in conjunction with an upstream microfilter or nanofilter	Removal of small amounts of gaseous contaminants, especially oil vapour Upstream nanofilter required With integrated microfilter
	Compressed air quality (ISO 8573-1)	Compressed air quality (ISO 8573-1)	Compressed air quality (ISO 8573-1)	Compressed air quality (ISO 8573-1)	Compressed air quality (ISO 8573-1)
	8	3	2	1	1
	-	-	2	1	1
	Material	Material	Material	Material	Material
	stainless steel	Acrylic fibre	Borosil. microfibre	Borosil. microfibre	Borosil. microfibre
	PA	Cellulose			Activated carbon

Compressed air maintenance units

Compressed air quality classes as per ISO8573-1:

Class	Particulate matter			Moisture and liquid water	Oil
	Maximum particle count per cubic metre as a function of the particle size ⁽¹⁾			Pressure dew point	Overall concentration oil ⁽¹⁾ (liquid, aerosol and water vapour)
	0.1 µm < d ≤ 0.5 µm	0.5 µm < d ≤ 1.0 µm	1.0 µm < d ≤ 5.0 µm	°C	mg/m ³
0	As stated by the device user or supplier and stricter than class 1				
1	≤ 20.000	≤ 400	≤ 10	≤ -70	≤ 0.01
2	≤ 400.000	≤ 6.000	≤ 100	≤ -40	≤ 0.1
3	not defined	≤ 90.000	≤ 1.000	≤ -20	≤ 1
4	not defined	not defined	≤ 10.000	≤ +03	≤ 5
5	not defined	not defined	≤ 100.000	≤ +07	not defined
6				≤ ±10	
	Mass concentration ⁽¹⁾ -C _p			Liquid water content ⁽¹⁾ - C _w	
	mg/m ³			g/m ³	
6	0 < C _p ≤ 5				not defined
7	5 < C _p ≤ 10			C _w ≤ 0.5	not defined
8	not defined			0.5 ≤ C _w ≤ 5	not defined
9	not defined				not defined
X	C _p > 10				> 5

To qualify for a class designation, each value range and each particle count within a class must be complied with.

(1) For reference conditions: Air temperature of 20 °C, absolute air pressure of 1 bar, relative water vapour pressure 0 bar.

Key:

- 1 Compressor
- 2 Condensate trap
- 3 Pressure vessel
- 4 Refrigeration dryer/adsorption dryer
- 5 Condensate drain
- 6 Filter
- 7 Activated carbon adsorber
- 8 Oil-water separator

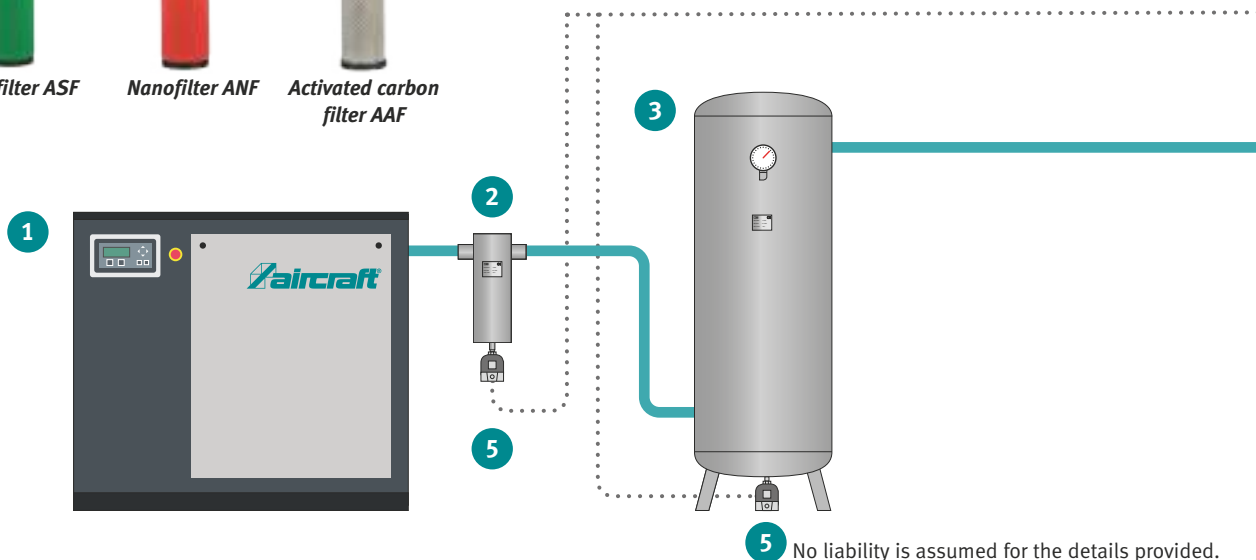

Compressed air quality classes

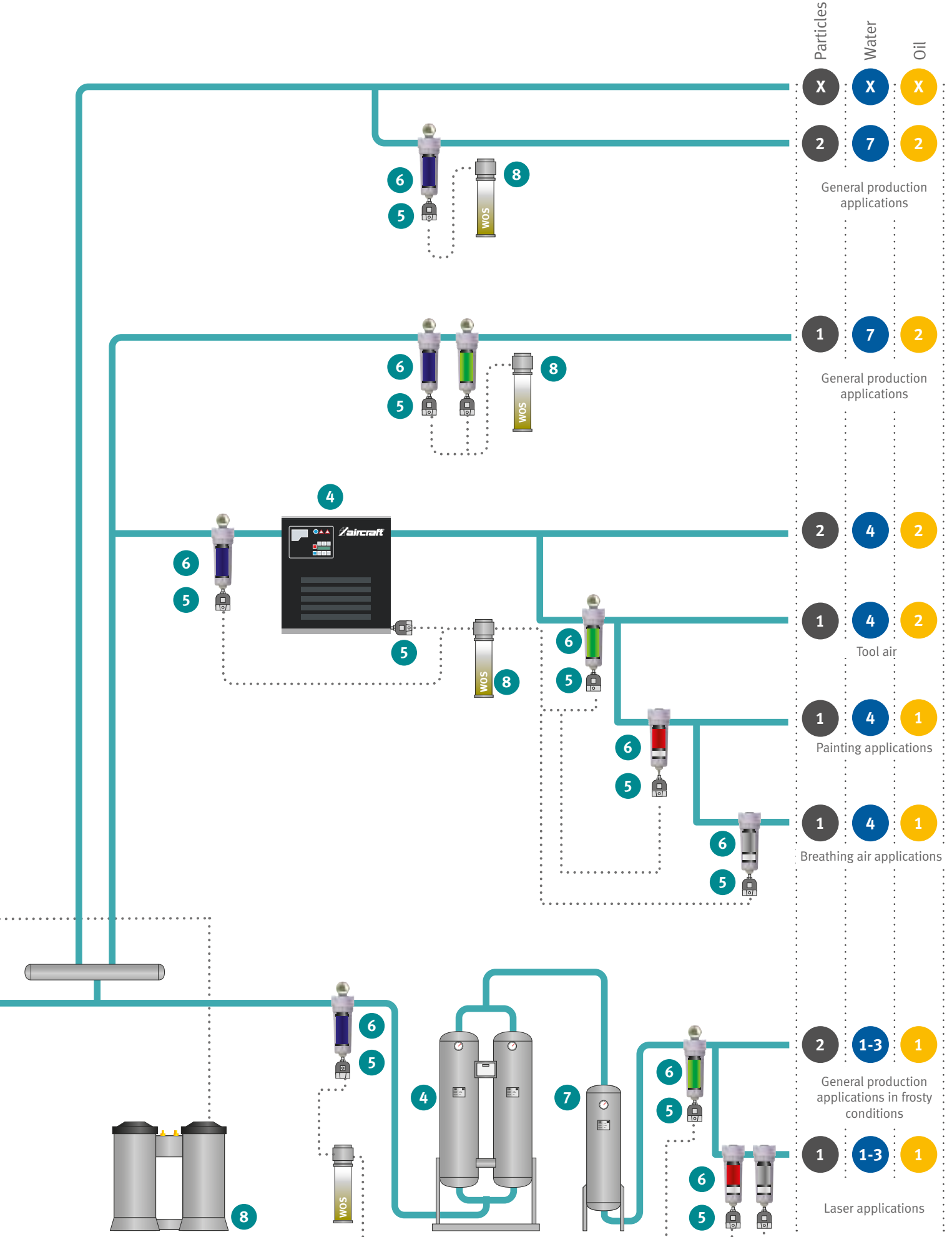

Condensate drain/oil-water separation devices

AIRCRAFT Electronic condensate drain AIED

- ▶ The AIED was designed for fully automatic drainage of condensate or other non-aggressive liquids mainly from filter housings.
- ▶ The condensate is collected in the catchment tank. When the level is high enough, the condensate is discharged without loss of air from the system
- ▶ The AIED is equipped with an LED indicator and a test button



Model	AIED
Art. no.	2059075
Max. filter capacity	55 m ³ /min
Operating pressure	0 - 16 bar
Voltage	230 V / 50-60 Hz
Performance	10 W
Separation performance (at 7 bar)	8 l/h
Operating temperature	1.5 - 45 °C (max 65 °C)**
Condensate feed	1/2" parallel thread
Degree of protection	IP54
Weight	0.3 kg

Timer-controlled condensate drain ZKA 16 Automatic condensate drain AOK 20 B

- ▶ For automatic, timer-controlled drainage of condensate or other non-aggressive liquids from the compressed air system
- ▶ Separation performance at 7 bar: 95 l/h, flow rate: 2.4 l/min
- ▶ Condensate feed T 1/2", condensate outlet T 1/4"
- ▶ Time ON / Time OFF: 0.5 - 10 s / 0.5 - 45 min
- ▶ Connection / IP degree of protection: 230 V / IP65
- ▶ Operating pressure: 16 bar, operating temperature range: 1.5 - 65 °C
- ▶ Dimensions: 77 x 79 x 93 mm



Type	Art. no.
ZKA 16	2059070

- ▶ For automatic, level-controlled drainage of condensate or other non-aggressive liquids from the compressed air system
- ▶ Compressed air temperature range: 1.5 - 65 °C
- ▶ For draining a higher volume of condensate from compressed air filters, pressure vessels and cyclone separators without air loss
- ▶ External drain with robust aluminium housing
- ▶ Separation performance at 7 bar: 167 l/h
- ▶ Condensate feed T 1/2", condensate outlet T 1/2"
- ▶ Additionally equipped with manual drain valve
- ▶ Max. working pressure: 20 bar
- ▶ Dimensions (A x B x C): 135 x 110 x 130 mm



Type	Art. no.
AOK 20 B	2053074

AIRCRAFT AMD electronic condensate drain - with patented valve technology

- ▶ For fully automatic drainage of condensate or other non-aggressive liquids from the compressed air system
- ▶ A capacitive sensor detects the condensate level. This is very accurate and requires no mechanical float and contacts.
- ▶ For installation as an external trap on piston or screw-type compressors, coolers, cyclone separators, compressed air vessels, air dryers and compressed air filters
- ▶ Equipped as factory standard with an operating alarm, LED indicator, test button and integral strainer
- ▶ A version with a service network for setting the diagnostic parameters and alarm output is available on request for quote

The advantages at a glance

- ▶ Integrated strainer (for easy access/cleaning)
- ▶ Compact design
- ▶ Patented valve technology - direct-action, self-cleaning valve
- ▶ Optimised for ease of service (service kit)
- ▶ Horizontal or vertical installation possible
- ▶ Robust PA housing
- ▶ Includes 2 meter connecting cable with safety plug

Functional description

- ▶ The condensate is collected in the catchment tank.
- ▶ When the level is high enough, the condensate is discharged without loss of air from the system
- ▶ The fluid level is precisely detected by a capacitive liquid level sensor
- ▶ The special, self-cleaning, direct-action valve ensures reliable operation.

Model	AMD
Art. no.	2059080

Separation performance 7 bar	12 l/h
Compressor output	7.4 m³/min
Dryer performance	14.9 m³/min
Filter performance	74.4 m³/min
Operating pressure	0 – 16 bar
Operating temperature	+1.5 to +65 °C
Connection	230 V
Condensate feed	T 1/2"
Condensate drain	Plug connection for hose Ø 8
Dimensions	133 x 76 x 147 mm
Weight	550 g



· Horizontal or vertical mounting possible

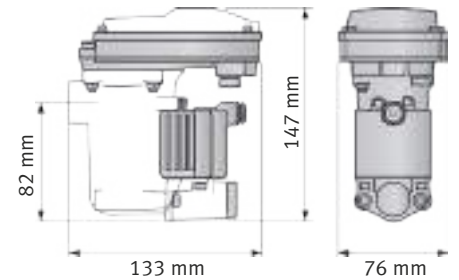

Designation	Art. no.
AMD assembly kit	9002715
AMD Maintenance kit	2059090

AIRCRAFT ACD Series electronic condensate drain - with patented valve technology

- ▶ The applications and function of the ACD series condensate drains are identical to the AMD series

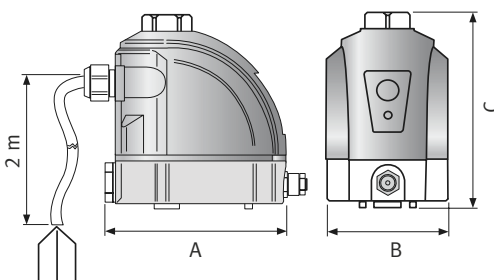

Model	ACD 90
Art. no.	2059086

Separation performance 7 bar	90 l/h
Compressor output	48.5 m³/min
Dryer performance	97.0 m³/min
Filter performance	485.0 m³/min
Operating pressure	0 – 16 bar
Temperature	+1.5 to +65 °C
Connection	230 V
Condensate feed	R 1/2"
Condensate drain	R 1/8"
Dimensions (A x B x C)	120 x 82 x 135 mm
Weight	1 050 g

The advantages at a glance

- ▶ Integrated microfilter
- ▶ Compact design
- ▶ Two connection options
- ▶ Robust anodised aluminium housing
- ▶ Contactless measurement
- ▶ Patented valve technology - direct-action, self-cleaning valve
- ▶ Operational monitoring
- ▶ LED warning light for "trap in operation" and "alarm"
- ▶ Includes 3 meter connecting cable with safety plug



Designation	Art. no.
ACD 90 Maintenance kit	2059094

Electronic condensate drain

Electronic condensate drain BEKOMAT® 31/32

In compressed air generation and treatment condensate inevitably forms; it contains oil and is frequently contaminated with dirt particles. As condensate accumulates irregularly depending on the season and time of day, or usage of the compressor, the BEKOMAT® often pays dividends within six months, thanks to its capacitive sensor, compared with timer-controlled drain valves.

The advantages at a glance

- ▶ No unnecessary loss of compressed air
- ▶ Discharge volume reflects occurrence volume
- ▶ Sensor detects any of condensate
- ▶ Less affected by dirt build-up
- ▶ Easy electrical installation (230 V)
- ▶ Low maintenance

Features and benefits:

- ▶ Usable and persistent with oil-based and oil-free, aggressive condensates
- ▶ Easily connected to a filter or vessel by adapting the inlet connector for vertical or horizontal condensate feed
- ▶ Improved drainage performance for oil/water separators with BEKOMAT®
- ▶ BEKOMAT® 32 with alarm and navigable fault messages

Functional description

- ▶ Condensate collects in the drain's catchment tank.
- ▶ A capacitive sensor detects the condensate level. At max. level a diaphragm opens; the condensate is discharged by system pressure.
- ▶ The diaphragm is closed before compressed air can escape



BEKOMAT® 32



BEKOMAT® 31



Including service unit

Economical: Complete replacement of all wear parts and pressure exposed parts in a single action.

- ▶ No electrical installation required for maintenance
- ▶ No installation of seals and parts
- ▶ Only one spare part, pressure and function tested at the factory

Model	BEKOMAT® 31	BEKOMAT® 32
Art. no.	2049049	2049053
Compressor output *	2.5 m ³ /min	5 m ³ /min
Dryer performance	5 m ³ /min	10 m ³ /min
Filter performance	25 m ³ /min	50 m ³ /min
Operating pressure	0.8 – 16 bar	0.8 – 16 bar
Temperature	+1 to +60 °C	+1 to +60 °C
Connection	230 V	230 V
Weight	800 g	1.000 g

* only with pre-separator

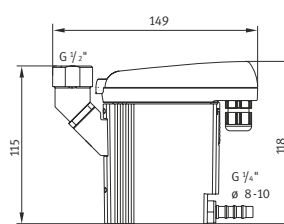

BEKOMAT® 31

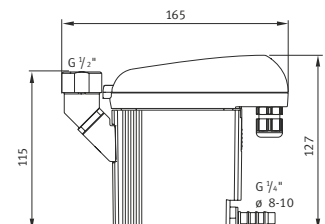

BEKOMAT® 32

Art. no.	Designation
2049060	Service Unit Bekomat 31
2049061	Service Unit Bekomat 32

ÖWAMAT® - Oil-water separation system

Functional description

- ▶ The oily condensate first flows under pressure into the pressure relief chamber (1) for treatment.
- ▶ The excess pressure is relieved here without creating turbulence in the downstream separation tanks for oil separation (2).
- ▶ Entrained coarse dirt particles are retained in a removable strainer (3).
- ▶ In the separation tank, the oil settles on the surface through gravity separation and is directed into the overflow-proof oil catchment tank (version available on request) (4).
- ▶ The filter makes all the difference: the pre-treated condensate flows through the oleophilic filter (5), which has a large active filter surface. As the flow passes through it from the

inside to the outside, it binds the remaining oil droplets and in the filter chamber additionally the residual, on floating oil.:

- ▶ The OEKOSORB® main filter with cartridge technology (6) reliably retains the last oil fractions. The remaining water can be run off directly into the drains.

The advantages at a glance

- ▶ Right-sized for your equipment
- ▶ Wall-mounting of ÖWAMAT® 10 and ÖWAMAT® 11 possible
- ▶ Long service life of filter units
- ▶ Simple retrofitting of heating possible
- ▶ Easiest handling thanks to cartridge technology
- ▶ Type-approval with and without oil separation
- ▶ No energy costs

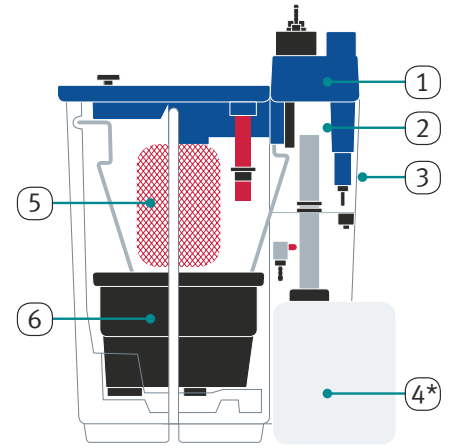

* Figure shows version with oil catchment tank - available on request



Öwamat 10



Öwamat 11



Öwamat 12 - models 14 and 16 similar



OEKOSORB® cartridge for quick and clean replacement



Variable connection in three directions

Accessories	Art. no.
Replacement filter set ÖWAMAT® 10	2049152
Replacement filter set ÖWAMAT® 11	2049153
Replacement filter set ÖWAMAT® 12	2049151
Replacement filter set ÖWAMAT® 14	2049154
Replacement filter set ÖWAMAT® 16	2049157
Bracket ÖWAMAT® 10	2047015
Bracket ÖWAMAT® 11	2047016

Model	ÖWAMAT® 10	ÖWAMAT® 11	ÖWAMAT® 12	ÖWAMAT® 14	ÖWAMAT® 16
Art. no.	2048010	2048011	2048012	2048014	2048016
Maximum compressor output*					
Screw-type compressors					
Turbine oil	2.4 m³/min	4.9 m³/min	7.3 m³/min	14.6 m³/min	58.5 m³/min
VDL oil	2.4 m³/min	4.9 m³/min	7.3 m³/min	14.6 m³/min	58.5 m³/min
VCL oil	1.9 m³/min	3.8 m³/min	5.6 m³/min	11.3 m³/min	45.0 m³/min
Synthetic oil: PAO	1.9 m³/min	3.5 m³/min	5.6 m³/min	11.3 m³/min	45.0 m³/min
Synthetic oil: Ester	1.6 m³/min	3.2 m³/min	4.8 m³/min	9.6 m³/min	38.3 m³/min
Piston compressors					
VDL oil	1.7	2.9	5.1	10.1	40.5
Synthetic oil: PAO	1.4	2.4	4.2	8.4	33.8
Synthetic oil: Ester	1.6	2.8	4.9	9.7	38.8
Condensate feed	2 x T 1/2"	2 x T 1/2"	3 x T 1/2" 1 x T 1"	3 x T 1/2" 1 x T 1"	3 x T 1/2" 1 x T 1"
water drain	T 1/2"	T 1/2"	T 1/2"	T 1"	T 1"
Dimensions max. (H x D x W)	230 x 270 x 525 mm	390 x 445 x 755 mm	350 x 397 x 719 mm	410 x 461 x 892 mm	650 x 702 x 1 193 mm

* These performance data apply for temperate climates (e.g., Central and Southern Europe, Central America). If required, please request compressor output data for other climates.

Oil-water separation devices

AIRCRAFT oil-water separation devices - Economical and environmentally friendly

Oil-water separation devices are used for treatment of oily condensate. They represent an environmentally-friendly and cost-saving solution for separating condensate and allow the disposal of the water separated from oil into drains as per Para. 7 of the Federal Water Act.

The incident condensate is a waste and

contaminated with oil content of up to 10 000 mg/l.

AIRCRAFT oil-water separation systems have technical approval by the Institut für Bautechnik (Institute for Building Technology), Berlin. They allow for condensate treatment on site. This is typically cheaper than costly waste-disposal by specialist companies.

Simple gravity separators (oil traps) are not suitable for the treatment of condensate from compressed air systems.

According to the Federal Water Act, Paragraph 7a, compressed air condensate must not be discharged into drains without proper treatment in line with the state of the art.

AIRCRAFT Oil-water separators series WOS 1 and 2 - patented technology

- ▶ Regular service is possible in just 30 seconds and without complex cleaning thanks to patented technology
- ▶ Wall- and floor mounting possible
- ▶ Works reliably with any condensate drain
- ▶ Can be used with any popular compressor oil
- ▶ Operating media: Condensate (air, water, oil), non-aggressive, not suitable for emulsion
- ▶ Fast and clean replacement of the filter element
- ▶ No settling tank required (no formation of bacteria)
- ▶ Easy installation due to compact design and small footprint
- ▶ Connection via quick-action couplings

- ▶ Function description:
- ▶ Multiple stage oil-water separation through an oleophilic filter and activated carbon
- ▶ At the end of the filter element's service life, it is unbolted and disposed of
- ▶ The filter element is tightly sealed with a plastic cover so that remaining condensate can stay in it
- ▶ The sealed filter element can be disposed of in line with applicable regulations

- ▶ **Service interval** (after one of the three following cases occurs):
- ▶ 4 000 hours of operation of the air compressor, or in case of compressor oil transmission of 2.5 mg/m³
- ▶ Discolouration of the polypropylene medium - analysis by simple visual inspection
- ▶ After twelve months at the latest (independently of the compressor's operating hours)

Model	WOS 1	WOS 2
Art. no.	2058210	2058220
Maximum compressor output*	1.08 m ³ /min	2.23 m ³ /min
Max. oil adsorption	650 g	1 340 g
Max. condensate flow	0.90 l/h	1.87 l/h
Residual oil content	< 20 ppm	< 20 ppm
Operating temperature	1.5 - 45 °C (max 65 °C)**	1.5 - 45 °C (max 65 °C)**
Condensate feed, connector	Ø 8 mm for hose	Ø 8 mm for hose
Water drain, connector	Ø 8 mm for hose	Ø 8 mm for hose
Dimensions max. (H x D x W)	483 x 146 x 106 mm	816 x 146 x 106 mm



Replacement cartridge

Art. no.	Designation
2058212	Replacement cartridge for WOS 1
2058222	Replacement cartridge for WOS 2

AIRCRAFT Oil-water separator series WOS 4/8/20/35

The advantages at a glance

- ▶ Patented system allows for regular inspection without time-consuming cleaning
- ▶ Equipped with polypropylene and activated carbon filter
- ▶ Wall- and floor mounting possible
- ▶ Works reliably with any condensate drain
- ▶ Can be used with any popular compressor oil
- ▶ Fast and clean replacement of the filter element
- ▶ No settling tank required
- ▶ Easy installation thanks to compact design
- ▶ Connection via quick-action couplings

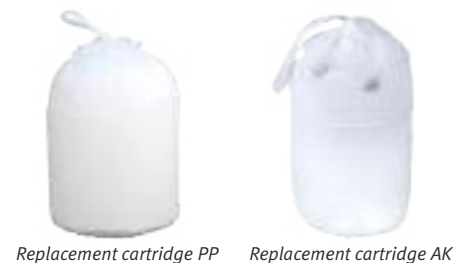

Replacement cartridge PP Replacement cartridge AK

Model	WOS 4	WOS 8	WOS 20	WOS 35
Art. no.	2058230	2058240	2058250	2058255
Max. delivery quantity*	4.04 Nm ³ /min	8.4 Nm ³ /min	20.5 Nm ³ /min	35.5 Nm ³ /min
Max. oil adsorption	2.43 kg	5.04 kg	12.28 kg	21.31 kg
Max. condensate flow	3.4 l/h	7.1 l/h	17.2 l/h	29.8 l/h
Residual oil content	< 10 ppm	< 10 ppm	< 10 ppm	< 10 ppm
Operating temperature	1.5 - 45 °C (max 65 °C)**			
Condensate feed, connector	Ø 10 mm for hose			
Water drain, connector	Ø 10 mm for hose			
Dimensions (L x W x H) in mm	416 x 243 x 411	730 x 343 x 680	820 x 366 x 940	960 x 386 x 1 137

Accessories WOS 4	Art. no.
Replacement cartridge PP	2058232
Replacement cartridge AK	2058233
Accessories WOS 8	
Replacement cartridge PP	2058242
Replacement cartridge AK	2058243
Accessories WOS 20	
Replacement cartridge PP	2058252
Replacement cartridge AK	2058253
Accessories WOS 35	
Replacement cartridge PP	2058257
Replacement cartridge AK	2058258

* These performance data apply for temperate climates (e.g., Central and Southern Europe, Central America). If required, please request compressor output data for other climates.

146 ** Max. operating temperature at 65 °C, however, performance may be impaired at temperatures above 45 °C

AIRCRAFT cyclone separator ACKL

- ▶ For highly efficient separation of large quantities of condensate from compressed air and vacuum systems
- ▶ Installed between the compressor and pressure vessel
- ▶ Filter housing made of aluminium with anodised interior
- ▶ Separation of condensate (water, oil) and dirt particles by centrifugal acceleration of the compressed air
- ▶ The condensate is separated via the water trap through the standard condensate drain with float valve
- ▶ Electronic condensate drain retrofittable



Cyclone ACKL - max. operating pressure 16 bar, operating temperature from 1.5 to 65 °C

Model	Volume flow		Air connection	Height in mm	Width in mm	Filter cpl. Art. no.
	m³/h	l/min				
	7 bar*					
ACKL 0120B	120	1.980	3/8"	247	88	2053010
ACKL 0155B	155	2.557	1/2"	247	88	2053012
ACKL 0235B	235	3,877	3/4"	337	88	2053014
ACKL 0365B	365	6.022	1"	363	125	2053016
ACKL 0770B	770	12.705	1 1/2"	601	125	2053018

* In case of deviating operating pressure, please multiply the specified volume flow by the appropriate correction factor.

Accessories

 You will find a large selection of condensate drains on pages 128 - 129 of this catalogue.

Differential pressure display PD 16

- ▶ For analysing the pressure drop caused by the filter element in the compressed air system; replace the filter element when the indicator shows red
- ▶ Max. operating pressure 16 bar, operating temperature from 1.5 to 65 °C



Type	Art. no.
PD 16	2053060

MDM 60 series differential pressure gauge

- ▶ Shows whether the filter element is still fully functional or needs to be replaced - replacement of the filter element is recommended in case of a pressure drop of 0.6 bar (start of red area on the display)
- ▶ For assembly on the top filter cover
- ▶ Max. operating pressure 16 bar, operating temperature from 1.5 to 65 °C



MDM 60



MDM 60 E



MDM 60 C

Type	Art. no.
MDM 60	2053062
MDM 60 E with LED alarm, battery-operated (battery included in scope of delivery)	2053064
MDM 60 C with zero-potential alarm contact	2053066

Wall-mounting kits for water separators and filters

- ▶ For mounting one or multiple connected filters on a wall



Fig. shows application

Type	Art. no.
Wall-mounting kit for filter AF0060-AF0120	2053080
Wall-mounting kit for filter AF0198-AF0510	2053082

Connecting kits AK for water separators and filters

- ▶ For connecting two housings
- ▶ Brackets for wall-mounting in scope of delivery
- ▶ Connecting kit can also be used for third-party housings



Type	Art. no.
AK 3/8"	2053090
AK 1/2"	2053091
AK 3/4"	2053092
AK 1"	2053093
AK 1 1/2"	2053094

Water trap/compressed air filter

AIRCRAFT compressed air filters - optimal air quality for all applications

Compressed air filters are used for highly efficient removal of solid particles, water, oil, aerosols, hydrocarbons, odours and vapours from compressed air systems.

In order to achieve the required quality of compressed air, filters that remove all types of solid and liquid contaminants from the compressed air in various stages, are installed in the compressed air line.

Your benefits thanks to improve compressed air quality:

- ▶ Reliable filtration of liquids such as water and aerosols as well as particles, dust and gases
- ▶ Optimum protection of connected equipment and tools

- ▶ Improved product quality due to substantial decrease in rejects
- ▶ Better working and production conditions
- ▶ Protects the compressed air system against contamination
- ▶ Increased productivity by reducing maintenance

Pre-filter/Microfilter AFF Model Series

For separating solid impurities up to **1 µm**. Operating temperature 1.5 to 65 °C, absolute compressed air quality as per ISO 8573-1.

For safe separation of condensate and particles

- ▶ Complete with filter element and float valve

Model	Volume flow 7 bar*		Air connection	height	Width	Filter complete		Spare filter element	
						Art. no.		Art. no.	
AFF 0060	60 m³/h	990 l/min	3/8"	187 mm	88 mm	2053230		2053231	
AFF 0078	78 m³/h	1 300 l/min	1/2"	187 mm	88 mm	2053232		2053233	
AFF 0120	120 m³/h	1 980 l/min	3/4"	257 mm	88 mm	2053234		2053235	
AFF 0198	198 m³/h	3 280 l/min	1"	263 mm	125 mm	2053236		2053237	
AFF 0335	335 m³/h	5 580 l/min	1"	363 mm	125 mm	2053238		2053239	
AFF 0510	510 m³/h	8 500 l/min	1 1/2"	461 mm	125 mm	2053240		2053241	

* In case of deviating operating pressure, please multiply the specified volume flow by the appropriate correction factor.



ASF Microfilter Model Range

For separation of solid impurities up to **0.1 µm**. Residual oil aerosol content of up to **0.1 mg/m³** at 20 °C and 1 bar, operating temperature 1.5 to 65 °C, absolute compressed air quality as per ISO 8573-1.

For safe separation of condensate and particles

- ▶ Complete with filter element and float valve

Model	Volume flow 7 bar*		Air connection	height	Width	Filter complete		Spare filter element	
						Art. no.		Art. no.	
ASF 0060	60 m³/h	990 l/min	3/8"	187 mm	88 mm	2053330		2053331	
ASF 0078	78 m³/h	1 300 l/min	1/2"	187 mm	88 mm	2053332		2053333	
ASF 0120	120 m³/h	1 980 l/min	3/4"	257 mm	88 mm	2053334		2053335	
ASF 0198	198 m³/h	3 280 l/min	1"	263 mm	125 mm	2053336		2053337	
ASF 0335	335 m³/h	5 580 l/min	1"	363 mm	125 mm	2053338		2053339	
ASF 0510	510 m³/h	8 500 l/min	1 1/2"	461 mm	125 mm	2053340		2053341	

* In case of deviating operating pressure, please multiply the specified volume flow by the appropriate correction factor.







MDM 60



MDM 60 E
With LED alarm, battery operated



MDM 60 C
With zero-potential alarm contact



PD 16



Water separator



Pre-filters/Microfilters



Micro filter



Nanofilters



Activated carbon filter

Correction factors for ACKL, AFF, ASF, ANF and AAF water traps and compressed air filters

In case of a deviating operating pressure, please multiply the specified volume flow by the appropriate correction factor

Operating pressure bar	2	3	4	5	6	7	8	9	10	11	12	13	14	15	16
Correction factors	0.38	0.50	0.63	0.75	0.88	1.00	1.13	1.25	1.38	1.50	1.63	1.75	1.88	2.00	2.13

ANF Model Range Nanofilters

For separating solid impurities up to **0.01 µm**. Residual oil aerosol content of up to **0.01 mg/m³** at 20 °C and 1 bar, operating temperature 1.5 to 65 °C, absolute compressed air quality as per ISO 8573-1.

For safe separation of condensate and particles

► Complete with filter element and float valve

Model	Volume flow 7 bar*		Air connection	height	Width	Filter complete		Spare filter element	
						Art. no.		Art. no.	
ANF 0060	60 m³/h	990 l/min	3/8"	187 mm	88 mm	2053430		2053431	
ANF 0078	78 m³/h	1 300 l/min	1/2"	187 mm	88 mm	2053432		2053433	
ANF 0120	120 m³/h	1 980 l/min	3/4"	257 mm	88 mm	2053434		2053435	
ANF 0198	198 m³/h	3 280 l/min	1"	263 mm	125 mm	2053436		2053437	
ANF 0335	335 m³/h	5 580 l/min	1"	363 mm	125 mm	2053438		2053439	
ANF 0510	510 m³/h	8 500 l/min	1 1/2"	461 mm	125 mm	2053440		2053441	



* In case of deviating operating pressure, please multiply the specified volume flow by the appropriate correction factor.

AAF model range activated carbon filters

For separating oil vapours, odours and flavours by adsorption, and solid particles in a second stage.

Residual oil vapour content of up to **0.005 mg/m³** at 20 °C and 1 bar, operating temperature 1.5 to 45 °C, absolute compressed air quality as per ISO 8573-1.

► For highest quality compressed air, for example, breathing air, in analysis technology or beverage bottling

► Purest compressed air in conjunction with upstream microfilter

► With filter element and manual drain

Model	Volume flow 7 bar*		Air connection	height	Width	Filter complete		Spare filter element	
						Art. no.		Art. no.	
AAF 0060	60 m³/h	990 l/min	3/8"	187 mm	88 mm	2053530		2053531	
AAF 0078	78 m³/h	1 300 l/min	1/2"	187 mm	88 mm	2053532		2053533	
AAF 0120	120 m³/h	1 980 l/min	3/4"	257 mm	88 mm	2053534		2053535	
AAF 0198	198 m³/h	3 280 l/min	1"	263 mm	125 mm	2053536		2053537	
AAF 0335	335 m³/h	5 580 l/min	1"	363 mm	125 mm	2053538		2053539	
AAF 0510	510 m³/h	8 500 l/min	1 1/2"	461 mm	125 mm	2053540		2053541	



* In case of deviating operating pressure, please multiply the specified volume flow by the appropriate correction factor.



Wall-mounting kit



Connecting kit



MCD



AOK 16 B



AOK 20 B



AIED



ZKA 16



AMD



BEKOMAT® 31/32

Water trap/compressed air filter

CLEARPOINT 3eco® compressed air filter - an innovative solution with impressive details

- ▶ **Flow optimised air guidance** for up to 75 % less resistance
- ▶ Filter elements can be installed with diameter-restricting, interfering tension rods, **thus reducing the flow resistance and facilitating element replacement**, even in cramped conditions
- ▶ **Total cavity volume** of borosilicate filter material **96 %** ensures lowest possible pressure loss
- ▶ CLEARPOINT® **filter housing of water-resistant aluminium** and additionally **anodised on the inside** for increased operational reliability and reduced flow resistance thanks to permanently smooth inside surfaces
- ▶ 100% assurance on opening the filter housing thanks to a **secure locking mechanism**; an audible warning signal is issued when opening under pressure
- ▶ With thermally highly-resistant (up to 120 °C), mechanically highly-resistant, chemically resistant and silicone-free **needle felt drainage layer** (in contrast foam material used by third-party filter brands)
- ▶ **Stable design of the filter element** - swelling or rupturing of the drainage layer ruled out, thus **ensuring permanent use of the entire filter surface**

Note

- ▶ The nanofilter **NWF** series has been replaced by the latest CLEARPOINT® 3eco **SWF** series compressed air filter which offer substantially improved oil separating performance and impress with up to 50% lower differential pressure
- ▶ This ensures even more process assurance and noticeable cost savings
- ▶ The new filters differ in terms of their internal values for the filter element, and are fully compatible with the filter elements of the previous generation at the same price.

Model changes:

Old

Model	Art. no.
S040 NWF	2045067
S050 NWF	2045100
S055 NWF	2045150
S075 NWF	2045300
M010 NWF	2045050

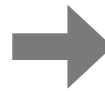

New

Model	Art. no.
S040 SWF	2044067
S050 SWF	2044100
S055 SWF	2044150
S075 SWF	2044300
M010 SWF	2044050

FWF microfilter model range

For separation of solid contaminants of up to **1 µm**, residual aerosol content of up to **0.1 mg/m³** at 20 °C and 1 bar, absolute compressed air quality as per ISO 8573-1.

- ▶ For safe separation of condensate and particles
- ▶ Complete with filter element and float valve

Model	Volume flow 7 bar*		Air connection	height	Width	Filter complete		Spare filter element	
						Art. no.		Art. no.	
S040 FWF	35 m³/h	580 l/min	3/8"	180 mm	75 mm	2042067		2042069	
S050 FWF	65 m³/h	1.080 l/min	1/2"	210 mm	75 mm	2042100		2042102	
S055 FWF	100 m³/h	1 670 l/min	1/2"	265 mm	75 mm	2042150		2042152	
S075 FWF	150 m³/h	2 500 l/min	3/4"	280 mm	100 mm	2042300		2042302	
M010 FWF	200 m³/h	3 340 l/min	1"	350 mm	100 mm	2042450		2042452	

* In case of deviating operating pressure, please multiply the specified volume flow by the appropriate correction factor.



SWF Nanofilter model range

for separation of solid impurities up to **0.1 µm**. Residual oil aerosol content of up to **0.01 mg/m³** at 20 °C and 1 bar, absolute compressed air quality as per ISO 8573-1.

- ▶ For safe separation of condensate and particles
- ▶ Complete with filter element and float valve

Model	Volume flow 7 bar*		Air connection	height	Width	Filter complete		Spare filter element	
						Art. no.		Art. no.	
S040 SWF	35 m³/h	580 l/min	3/8"	180 mm	75 mm	2044067		2044069	
S050 SWF	65 m³/h	1.080 l/min	1/2"	210 mm	75 mm	2044100		2044102	
S055 SWF	100 m³/h	1 670 l/min	1/2"	265 mm	75 mm	2044150		2044152	
S075 SWF	150 m³/h	2 500 l/min	3/4"	280 mm	100 mm	2044300		2044302	
M010 SWF	200 m³/h	3 340 l/min	1"	350 mm	100 mm	2044050		2044452	

* In case of deviating operating pressure, please multiply the specified volume flow by the appropriate correction factor.



AWM model range activated carbon filters

for separating oil vapours, odours and flavours by adsorption, and solid particles in a second stage. Residual oil vapour content of up to **0.003 mg/m³** at 20 °C and 1 bar, absolute compressed air quality as per ISO 8573-1.

- ▶ For highest quality compressed air, for example, breathing air, in analysis technology or beverage bottling
- ▶ Purest compressed air in conjunction with upstream microfilter
- ▶ With filter element and manual drain

Model	Volume flow 7 bar*		Air connection	height	Width	Filter complete		Spare filter element	
						Art. no.		Art. no.	
S040 AWM	35 m³/h	580 l/min	3/8"	180 mm	75 mm	2046067		2046069	
S050 AWM	65 m³/h	1.080 l/min	1/2"	210 mm	75 mm	2046100		2046102	
S055 AWM	100 m³/h	1 670 l/min	1/2"	265 mm	75 mm	2046150		2046152	
S075 AWM	150 m³/h	2 500 l/min	3/4"	280 mm	100 mm	2046300		2046302	
M010 AWM	200 m³/h	3 340 l/min	1"	350 mm	100 mm	2046450		2046452	

* In case of deviating operating pressure, please multiply the specified volume flow by the appropriate correction factor.



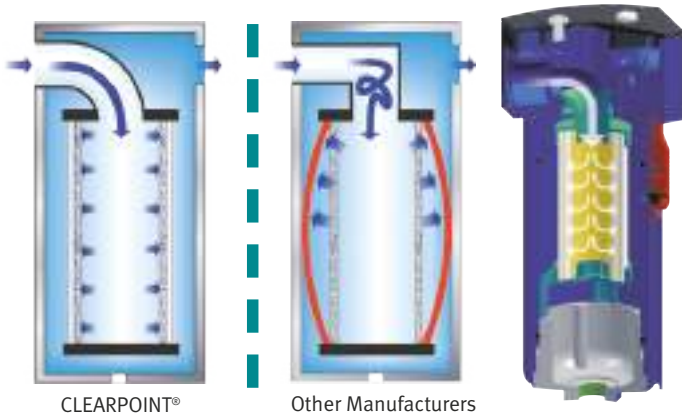

Efficiency CLEARPOINT® water separators

The flow-optimised design achieves an efficiency of up to 99% across a wide performance range. This means maximum separation rates at a low cost.

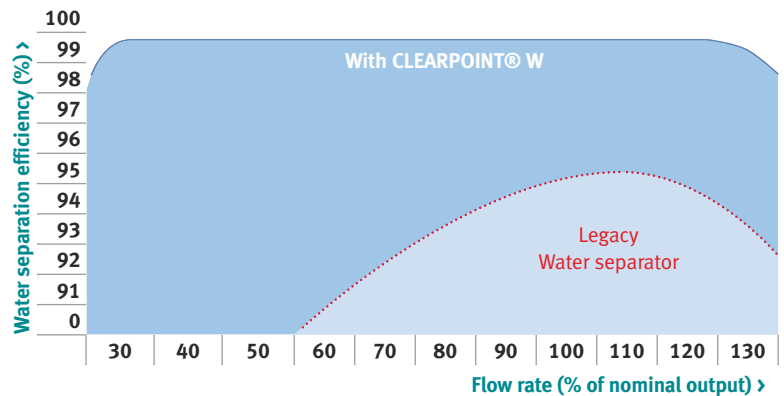

Correction factors WWB water trap and Filter FWF, SWF, NWF and AWM compressed air filters

In case of a deviating operating pressure, please multiply the specified volume flow by the appropriate correction factor

Operating pressure bar	0.3	0.6	1	2	3	4	5	6	7	8	9	10	11	12	13	14	15	16
Correction factors	0.21	0.29	0.38	0.53	0.65	0.76	0.84	0.92	1	1.070	1.13	1.19	1.25	1.31	1.36	1.41	1.46	1.51

CLEARPOINT® Model Range WWB water separator

- ▶ 99% separation of occurring condensate directly downstream of the compressor
- ▶ For separation of large volumes of condensate (water, oil) and dirt particles by centrifugal acceleration of the compressed air
- ▶ Used on re-coolers and refrigeration dryers
- ▶ Completely anodised for premium corrosion protection
- ▶ Flow-optimised housing made of salt water resistant aluminium
- ▶ Outside additionally powder coated
- ▶ Max. positive operating pressure 16 bar, differential pressure < 0.06 bar
- ▶ With BEKOMAT® condensate drain

Model	Volume flow 7 bar*		Air connection	height	Width	Art. no.	Filter complete
	m³/h	l/min					
S040 WWB	46	580	3/8"	395 mm	75 mm	2048000	
S050 WWB	130	1 670	1/2"	425 mm	75 mm	2048001	
S075 WWB	195	2 500	3/4"	495 mm	100 mm	2048002	
M010 WWB	325	3 340	1"	565 mm	100 mm	2048003	

* In case of deviating operating pressure, please multiply the specified volume flow by the appropriate correction factor. S040 to S050 with Bekomat® 20; S075 and M010 with Bekomat® Vario 20



Accessories

Oil test indicator

- ▶ For approximate determination of the compressed air residual oil content at the AWM activated charcoal filters



Type	Art. no.
Oil test indicator for AWM model range	2047005
Replacement test tubes with needle valve	2047006

Wall-mounting kits for water separators and filters

- ▶ For mounting one or multiple connected filters on a wall

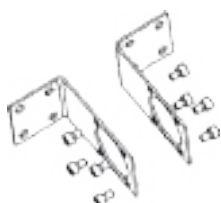

Type	Art. no.
Wall-mounting kit for S040, S050, S055	2047001
Wall-mounting kit for S075, M010	2047002

Connecting kits for water separators and filters

- ▶ For connecting two housings

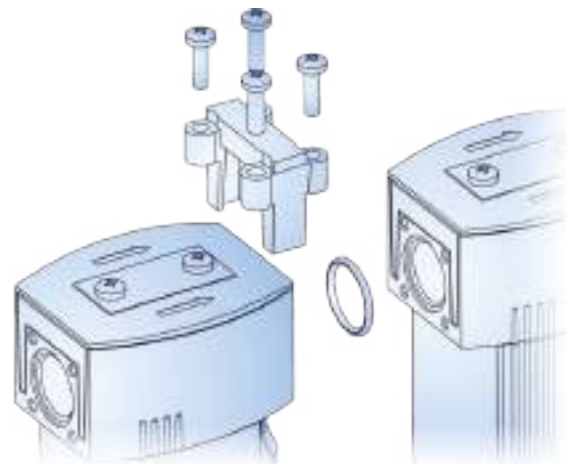

Type	Art. no.
Connecting kit for S040, S050, S055	2047003
Connecting kit for S075, M010	2047004

Compressed air refrigeration dryer

AIRCRAFT compressed air refrigeration dryers - leverage potential savings and reduce maintenance costs

Compared to investment outlay, the energy costs are by far the biggest part of total cost of ownership. And this is naturally where the greatest savings potential exists.

In addition to reducing the energy costs, AIRCRAFT refrigeration dryers also permanently reduce maintenance costs.

Moisture is the greatest potential threat to all components that come into contact with it. It starts at a relative compressed air moisture content of around 70%, for bacteria already start to form at this low moisture value. As of 40% relative humidity, the corrosion process then grows disproportionately.

In the majority of all applications, the requirements for cooling and drying are simply "normal values": cooling to nearly 0 °C and thus close to 100% condensing of the water vapour contained in the compressed air. AIRCRAFT refrigeration dryers ensure effective separation of compressed air and water vapour, as well as safe separation of the condensate. An automatic condensate drain reliably handles condensate separation.

Design data for compressed air dryers

Reference conditions as per DIN ISO 7183

Volume flow relative to 20 °C at 1 bar, operating pressure 7 bar, compressed air ingress temperature 35 °C, cooling air temperature 25 °C, pressure dew point 5 °C. All models equipped with an automatic condensate drain as a factory standard.

Conversion factors

Please adapt the performance data by multiplying by the appropriate correction factor.

Operating pressure bar	4	5	7	8	10	12	14	
Correction factor AD and ASD	0.78	0.85	1	1.06	1.15	1.2	1.24	
Compressed air inlet temperature °C	30	35	40	45	50	55		
Correction factor AD and ASD	1.2	1	0.85	0.71	0.58	0.49		
Ambient temperature °C	25	30	35	40	42	45		
Correction factor AD and ASD	1	0.96	0.92	0.88	0.85	0.8		
Pressure dew point °C	3	4	5	6	7	8	9	10
Correction factor AD	0.92	0.96	1	1.04	1.09	1.13	1.18	1.2
Correction factor ASD	1	1.04	1.09	1.14	1.18	1.25	1.3	1.33

 Optimum protection for your refrigeration dryer from pollution can be achieved by use of a pre-filter

Refrigerated Air Dryer AD Series - the efficient solution for dry compressed air

- ▶ User-friendly operating concept
- ▶ Efficient design for low cost and safe operation
- ▶ Cooling fan speed controlled from 0 - 100%, thus eliminating the typical pressure switch and the thermostat for fan control.
- ▶ Fewer wear parts at the same constant pressure dew point
- ▶ Control shows five different alarm conditions and keeps them in memory
- ▶ Refrigeration compressor switches off at below 15 °C ambient temperature, if there is no compressed air flow
- ▶ Visibility of and easy access to all serviceable components
- ▶ With built-in automatic condensate drain



The advantages at a glance

- ▶ Excellent economy
- ▶ Excellent price-performance ratio
- ▶ No unnecessary loss of compressed air through built-in automatic condensate drain
- ▶ Connected tools and machines are optimally protected
- ▶ User-friendly operating concept



Model	Air flow		Maximum pressure in bar	Air connection	Power draw in kW	Weight in kg	Dimensions L x W x H	Art. no.
	l/min.	m ³ /h						
AD 36	600	36	16	3/8"	0.12	17	305 x 360 x 404	2041710
AD 54	900	54	16	1/2"	0.18	24	325 x 430 x 445	2041715
AD 72	1 200	72	16	1/2"	0.2	24	325 x 430 x 445	2041720
AD 108	1 800	108	16	1/2"	0.2	24	325 x 430 x 445	2041725
AD 144	2 400	144	16	3/4"	0.41	31	395 x 486 x 565	2041730
AD 180	3 000	180	16	3/4"	0.47	36	395 x 486 x 565	2041735
AD 216	3 600	216	16	3/4"	0.61	40	395 x 486 x 565	2041740
AD 280	4 666	280	16	1"	0.6	59	485 x 595 x 614	2041745
AD 340	5.666	340	16	1"	0.6	60	485 x 595 x 614	2041750

Art. no.	Designation
2041700	Bypass 1/2"
2041701	Bypass 3/4"

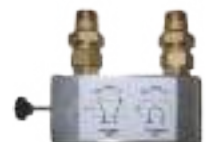

ASD Refrigerated Air Dryer Series - Energy-saving, patented and pioneering

Higher efficiency – lower costs

The innovative and highly efficient ASD Series uses a patented 3-circuit heat exchanger system. In combination with the glycol circuit, this achieves significant energy savings. The glycol acts as a cold-storage medium. ASD dryers are best suited for partial load operation and irregular compressed air requirements.

You can significantly save on operating costs by using ASD dryers.

Functional principle and advantages of the glycol-water circuit; the glycol mixture is cooled if not all of the cooling energy is required for cooling the compressed air. When the refrigerant compressor switches off in partial load operation, the compressed air is cooled by the cold stored in the glycol mass. The chiller is only switched back again when the mass is no longer cold enough. ASD dryers particularly realise saving potentials in partial load operation and where compressed air requirements are intermittent. When the air compressor starts up again after a break, and delivers compressed air into the network, ASD dryers immediately cool this compressed air to dew point because the glycol mass immediately provides the required temperature. In many other systems where the refrigeration compressor needs a ramp-up period to operating temperature before it can start cooling, moist air initially flows into the network, with all its negative effects.

The advantages at a glance

- ▶ Improved energy efficiency thanks to the patented 3-circuit heat exchanger system
- ▶ Energy savings and longer service life by switching off the refrigeration compressor in partial load operation
- ▶ Optimum dew point control with additional temperature sensor for glycol control
- ▶ Condensate drainage without pressure loss through integrated electronic, level-controlled condensate separator
- ▶ Optimal performance under all load and ambient conditions with variable fan speed control

- ▶ Use of premium components ensures longevity and considerably reduces service costs
- ▶ Reducing operating costs while actively protecting the environment



ASD 72



ASD 300

The functional principle of the patented 3-circuit heat exchanger system

1. Warm moisture-saturated air flows into the heat exchanger.
2. The intake air is pre-cooled by the counter flowing, cold outlet air from the heat exchanger.
3. The inlet air is brought to dew point temperature by the refrigerant circuit; condensate is formed.
4. Condensate is trapped and removed in the integrated electronic, level-controlled condensate separator.
5. Glycol circuit stores excess energy and cools the incoming air in partial load operation.
6. The refrigeration compressor shuts off at partial load, thus potentially doubling its service life. (See note on this page below functional principle and advantages of the glycol circuit)

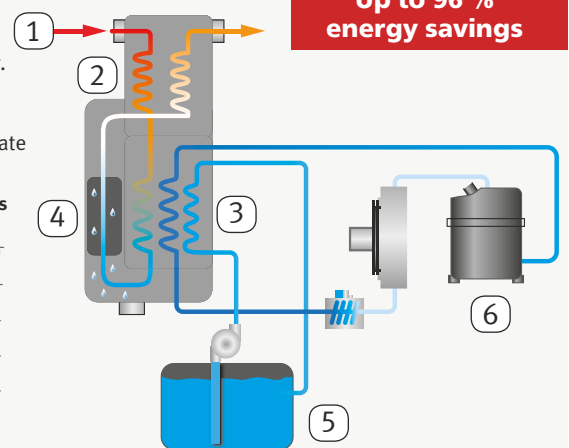
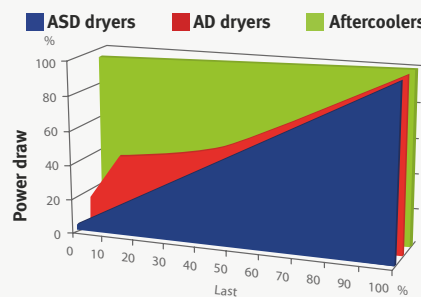

Model	Air flow		Max. Pressure in bar	Air connection	Power draw in kW	Weight in kg	Dimensions L x W x H	Art. no.
	l/min	m ³ /h						
ASD 54	900	54	16	1/2"	0.24	33	386 x 500 x 651	2041810
ASD 72	1 200	72	16	1/2"	0.29	35	386 x 500 x 651	2041815
ASD 108	1 800	108	16	3/4"	0.45	45	386 x 500 x 651	2041820
ASD 144	2 400	144	16	3/4"	0.51	50	386 x 500 x 651	2041825
ASD 180	3 000	180	16	1"	0.65	60	420 x 567 x 771	2041830
ASD 240	4 000	240	16	1"	0.64	70	420 x 567 x 771	2041835
ASD 300	5 000	300	16	1 1/2"	0.94	95	500 x 730 x 980	2041840
ASD 360	6 000	360	16	1 1/2"	0.94	100	500 x 730 x 980	2041845
ASD 480	8 000	480	16	1 1/2"	1.28	130	500 x 730 x 980	2041850

Art. no.	Designation
2041700	Bypass 1/2"
2041701	Bypass 3/4"



Compressed air distribution



AIRCRAFT plug-in compressed air network systems - a systematic approach to cost-savings

Your benefits

- ▶ Corrosion-free
- ▶ Simple assembly
- ▶ Easy and fast installation
- ▶ Can be disconnected and connected multiple times
- ▶ Plastic and aluminium pipe

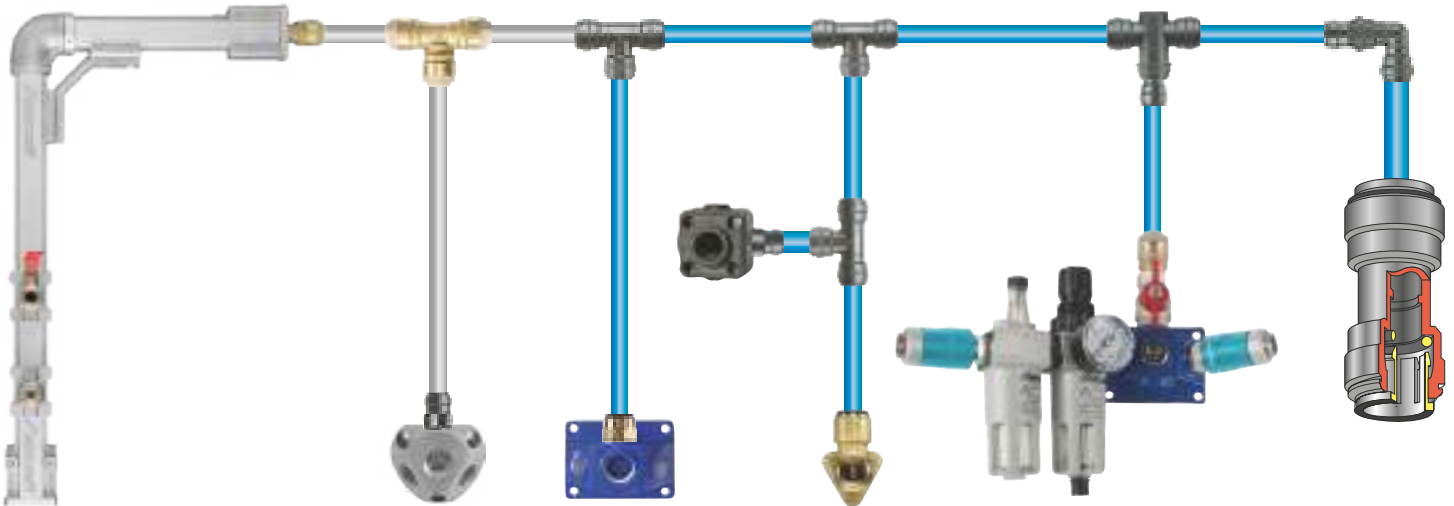

Do you have questions about planning the compressed air system in your workshop or production?

Ask us for advice!

Ask your local specialist dealer. They will be happy to give you comprehensive advice, without any obligation, about your AIRCRAFT compressed air solution. We are also happy to advise you. This gives you the most economical and cost effective solution.

How AIRCRAFT compressed air advisory service works...

Mail the floor plan of your building project to us, whether this is a new building, or you are expanding or refurbishing. State the number of workplaces and which tools you want to provide with compressed air. We will send you a plan tailored to suit your operation.

AIRCRAFT Germany:
Email: info@aircraft-kompressoren.de
Phone: + 49 (0) 9 51 96 - 555 - 0

AIRCRAFT Austria:
Email: info@aircraft.at
Phone: + 43 - (0) 77 52 - 70 929 - 0



See the following pages to discover more ...

Compressed air line systems

Compressed air solutions tailored to your needs



Screw-type compressor

Model	A-K-MAX 7.5-10
Art. no.	2095404



Vessel

Model	DB zinc plating 500/11 V
Art. no.	2500650

- Galvanised vessel**
- ▶ Without fitting kit
 - ▶ 500 l upright
 - ▶ Maximum pressure: 11 bar
 - ▶ 690 x 640 x 1 950 mm



Fitting kit

Model	Fitting set for DB VZ 500/11 V
Art. no.	2500530

- ▶ 1 reducing nipple 1½" (OT) – ¾" (IT)
- ▶ 1 safety valve ¾" 10 bar
- ▶ 2 dummy plugs 1¼"
- ▶ 1 reducing nipple 1" (OT) – ½" (IT)
- ▶ 2 bends 90° ½" IT/OT
- ▶ 1 pressure gauge ½" 0-16 bar
- ▶ 1 dummy plug ½"
- ▶ 1 three-way ball valve ½"
- ▶ 2 ball valve 1¼" IT/OT
- ▶ 1 reducing nipple 1½" (OT) – ½" (IT)



Automatic condensate drain

Model	AMD	AIED
Art. no.	2059080	2059075



Cyclone separator ACKL

Model	ACKL 0155B
Art. no.	2053012

- ▶ Flow rate: 2 557 l/min.
- ▶ Air connection: ½"
- ▶ Max. working pressure: 16 bar



Fine filter AFF

Model	AFF 0078
Art. no.	2053232

- AFF 0078 up to 0.1 µm**
- ▶ Flow rate: 1 300 l/min.
 - ▶ Air connection: ½"
 - ▶ Volume flow: 7 bar



Nanofilter ANF

Model	ANF 0078
Art. no.	2053433

- ANF 0078 up to 0.01 µm**
- ▶ Flow rate: 1 300 l/min.
 - ▶ Air connection: ½"
 - ▶ Volume flow: 7 bar



Activated carbon filter AAF

Model	AAF 0078
Art. no.	2053533

- AAF 0078 up to 0.005 mg/m³**
- ▶ Flow rate: 1 300 l/min.
 - ▶ Air connection: ½"
 - ▶ Volume flow: 7 bar





Condensate conditioner
for oil-water separation

Model	WOS 1	WOS 2
Art. no.	2058210	2058220



G1 G2
Compressed air energy saver

Model	G1	G2
Art. no.	2150001	2150003

Energy savers

Opens and closes automatically,
pressure range 0-16 bar

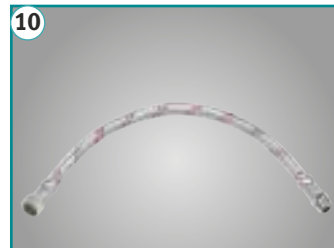

Reinforced hose

Model	Reinforced hose 1/2"
Art. no.	1500 mm / 15 bar 2507617

Model	Reinforced hose 3/4"
Art. no.	1500 mm / 15 bar 2507625



Bypass

Model	Bypass 1/2"
Art. no.	2041701

Model	Bypass 3/4"
Art. no.	2041700



A water separator ① is also located directly downstream of the screw-type compressor ④ for 98% water pre-separation.

The compressed air then reaches the pressure vessel ② which is equipped with a level-controlled condensate drain ③.

From the vessel, the flow is routed through a fine filter ⑤ to the compressed air refrigerant type dryer ⑫.

Depending on the requirements, nanofilters ⑥, for separating ultra-fine particles, and/OR an activated carbon filterS ⑦, for separating oil vapours, odorants, and flavourings, then follow.

Screw-type and piston compressors can be combined in a single system to cope with peak loads.

Our matching auxiliary Airprofi BK series compressors are listed in this catalogue.



Compressed air refrigeration dryer

Model	Refrigeration dryer AD 54
Art. no.	2041715

Refrigeration dryer AD 54

► Flow rate at 7 bar positive pressure: 54 m³/h

Model	Refrigeration dryer AD 72
Art. no.	2041720

Refrigeration dryer AD 72

► Flow rate at 7 bar positive pressure: 72 m³/h

Model	Refrigeration dryer AD 108
Art. no.	2041725

Refrigeration dryer AD 108

► Flow rate at 7 bar positive pressure: 108 m³/h

Compressed air pipe systems - Ø 15-28 mm

AIRCRAFT compressed air line plug-in system - The higher material price immediately pays for itself and gives you permanent savings!

- ▶ Fast installation without tools - simply plug in to connect
- ▶ Reduces the installation time by up to 50%
- ▶ No additional sealing material needed
- ▶ Suitable for use with various metal or plastic pipes
- ▶ Can be disconnected and connected multiple times
- ▶ Smooth interior surfaces, excellent flow properties
- ▶ Flexible modular system
- ▶ Virtually maintenance free
- ▶ Quality manufactured ISO 9001 (or EN 29001)

Due to the low installation costs and massive time savings during installation, the higher material costs immediately pay dividends

In the long-term lower operating and maintenance costs translate to savings.

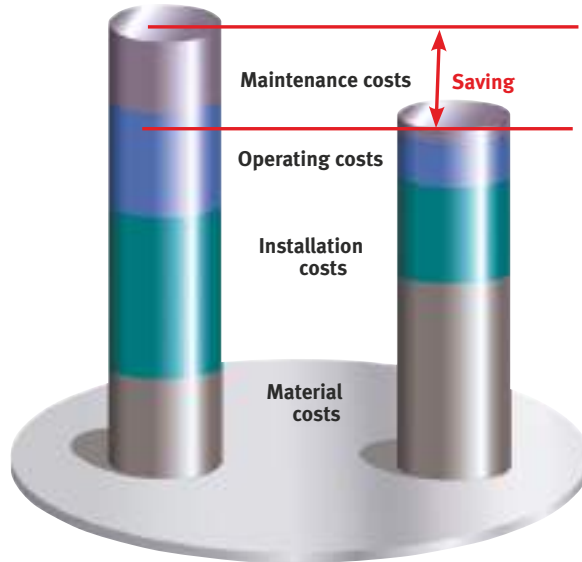

System installation/expansion in three easy steps:

- 1) Trim the pipe
- 2) Deburr
- 3) Plug in

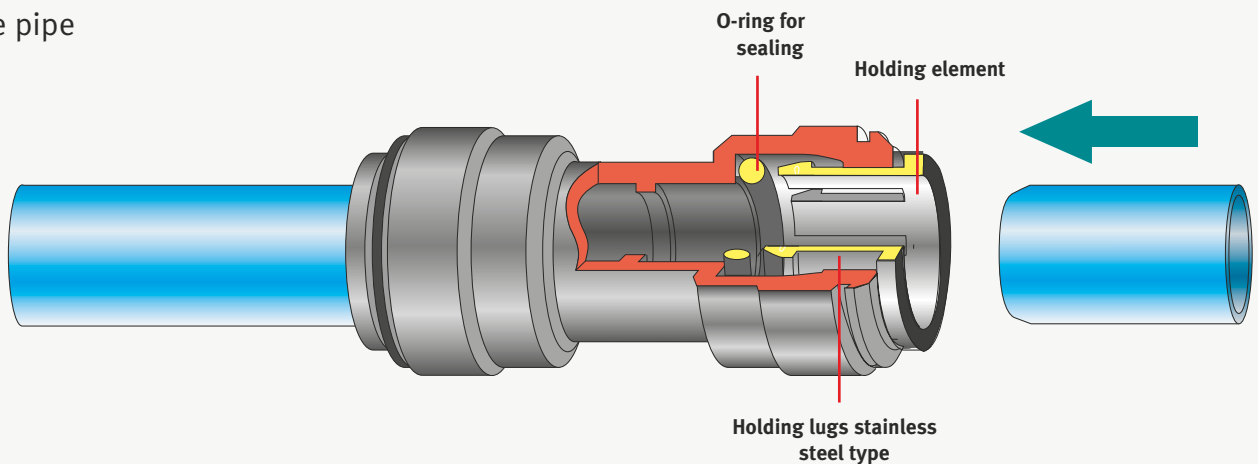

Advantages of the AIRCRAFT plastic compressed air line system compared with a metal system

Benefits of AIRCRAFT plastic compressed air connectors

- ▶ Very lightweight due to plastic material
- ▶ Specifically designed for compressed air engineering, not hydro-engineering
- ▶ Easy to disconnect and rotate
- ▶ Uniform material in the compressed air line
- ▶ No metal in the cable duct thanks to the use of plastic pipes
- ▶ Tried and trusted for decades

Metal pipe screw-type system, time-consuming work processes

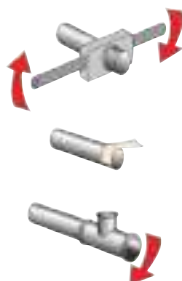

Adhesive systems, preparation overhead, and long bonding or drying time

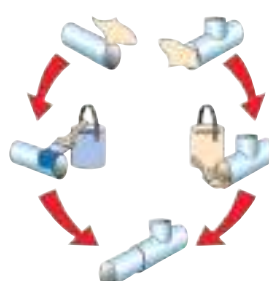

Although we generally recommend the use of plastic or aluminium pipes, it is also possible to use pipes made of other materials (copper, brass, etc.) with our connectors. Thus, existing pipe networks systems can be modified or extended using AIRCRAFT connectors.

Creating connections without tools

The pluggable connectors ensure a durable, safe and tight connection between the pipe and the connecting element. They are ideal for use in complex pipe networks, as well as in training and testing institutes where systems are frequently disconnected and reconnected. Various interface options mean that existing pipe systems can be modified or refurbished easily.

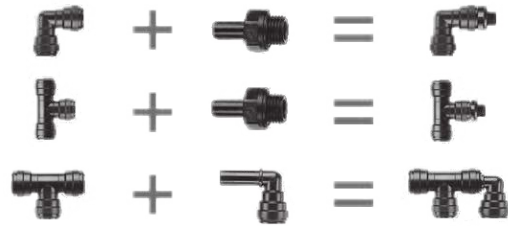

Connecting Ø 15 - Ø 22 mm

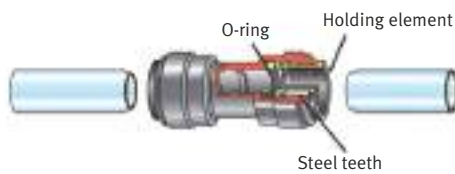

The product range is made of acetal copolymer (POM) and consists of the connector body, holding elements with stainless steel teeth and NBR o-rings for sealing. The connectors can be installed and removed without using tools. **The connection holds before it seals!**

Connecting Ø 28 mm

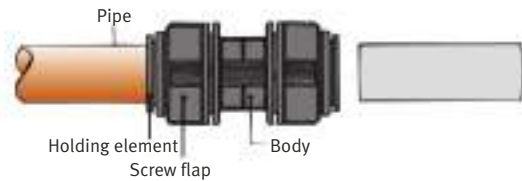

The 28 mm system consists of the connector body, holding elements with stainless steel teeth and NBR o-rings. Additional screw caps secure the retaining system and press the o-rings onto the pipe. The connectors can be installed and removed without using tools. **The connection holds before it seals!**



Connecting the Ø 15 - 22 mm system

Cut off the pipe square and burr-free. Make sure that the pipe has no sharp edges, longitudinal grooves or other damage. Insert the pipe up to the stop. The holding element fixes the tube in the connector. The o-ring ensures a permanently tight connection.



Connecting the Ø 28 mm system

Like with the other sizes a reliable connection can be made here simply by inserting the pipe. See the procedure on the left "Connecting". The retaining system is additionally secured with a 1/4 turn (two clicks) and the o-rings are pressed onto the surface of the pipe.



Check the connection by pulling in the opposite direction

Make sure that the pipe is safely inserted. You can easily do this by pulling.



Check the connection by pulling in the opposite direction

Make sure that the pipe is safely inserted. You can easily do this by pulling.



Disconnecting the Ø 15 - 22 mm system

Make sure the system is depressurised. You can then release or remove the pipe by pushing back the holding element.



Disconnecting the Ø 28 mm system

To disconnect the pluggable pipe connection, turn the screw a 1/4 turn anti-clockwise. The connection is now unlocked and can be released by pushing the holding element. See the procedure on the left "Disconnecting".

Compressed air pipe systems - Ø 15-28 mm

Determining the compressed air line diameter

Compressed air distribution with a closed circular pipeline

To dimension the closed circular pipeline, you need to work with half the nominal length of the entire circuit and the entire compressed air requirement.

Example:

Compressed air consumption 1 000 l/min., operating pressure 7 bar, total pipeline length is 300 m, work with 150 m for a closed circular pipeline

Length	25 m	50 m	100 m	150 m	200 m	250 m	300 m
Compressor delivery volume							
200 l/min	12	12	12	15	15	15	18
400 l/min	12	12	15	15	15	18	18
500 l/min	15	15	15	18	18	18	18
750 l/min	15	15	18	18	18	22	22
1 000 l/min	15	15	18	18	22	22	22
1 500 l/min	18	18	18	22	22	22	22
2 000 l/min	18	18	22	22	22	28	28
3 000 l/min	22	22	28	28	28	28	28
4 000 l/min	28	28	28	28	28	28	28

To determine the required pipe length for a main, supply and branch pipe, it is recommended to design the supply line as a closed circular pipeline; in this case half the line length and the total supply volume can be assumed in dimensioning.

Compressed air distribution with branch lines

To dimension the branch, you need to work with the total nominal pipe length and the entire compressed air requirement.

Example:

Compressed air consumption 1 000 l/min, operating pressure 7 bar, total pipeline length 300 m

Length	25 m	50 m	100 m	150 m	200 m	250 m	300 m
Compressor delivery volume							
200 l/min	12	12	12	15	15	15	18
400 l/min	12	12	15	15	15	18	18
500 l/min	15	15	15	18	18	18	18
750 l/min	15	15	18	18	18	22	22
1 000 l/min	15	15	18	18	22	22	22
1 500 l/min	18	18	18	22	22	22	22
2 000 l/min	18	18	22	22	22	28	28
3 000 l/min	22	22	28	28	28	28	28
4 000 l/min	28	28	28	28	28	28	28

Further technical details on request. **All values stated here are theoretical computations and are therefore not binding.** An individual pipe network must be precisely calculated and tailored to local conditions.

Determination of the pipe network length; flow characteristics

The values of the substitute pipe lengths need to be added to the actual pipe length, to provide pipeline length L in terms of the flow characteristics:

Spare tube line length per item

	Outside Ø	15	18	22	28
	Inside Ø	12	14	18	23
Fittings	Comparable with	3/8"	1/2"	3/4"	1"
Ball valve		0.1 m	0.2 m	0.3 m	0.4 m
Angle		0.7 m	1 m	1.3 m	1.5 m
T-piece		0.85 m	1 m	1.5 m	2 m
Reducer		0.4 m	0.45 m	0.5 m	0.6 m

Arithmetic example for determining the effective pipeline length L:

Planned components	Spare tube line length	Nominal length
2 x T-piece Ø 18 mm	1 m	2 m
3 x bend Ø 18 mm	1 m	3 m
1 x ball valve Ø 18 mm	0.2 m	0.2 m
Total		5.2 m

Effective pipeline length: planned length + total nominal length

Flow rates for plastic tubes and aluminium pipes

Pipe Ø mm	Plastic pipe Main pipe 6 m/sec. at 8 bar	Plastic pipe Main pipe 15 m/sec. at 8 bar	Aluminium pipe Main pipe 6 m/sec. at 8 bar	Aluminium pipe Main pipe 15 m/sec. at 8 bar
15	365 l/min	916 l/min	430 l/min	1 004 l/min
18	498 l/min	1 248 l/min	650 l/min	1 548 l/min
22	823 l/min	2 057 l/min	1 018 l/min	2 442 l/min
28	1 344 l/min	3 367 l/min	1 720 l/min	4 160 l/min

The indicated valves for the flow rate in the main pipe can change in case of flow in both directions. Other values for larger pipe diameters are available upon request.

Technical properties of connectors with Ø 15-32 mm

Working pressure and temperature range

Working temperatures* air	Working pressure*
20 °C	10 bar
1 °C	10 bar
+ 23° C	10 bar
+ 70° C	7 bar

* The pressure values depend on the pipe material. Please contact us in case of applications with liquids or vacuum.

Depending on the hoses used, it may be possible to use connectors for **higher pressures and temperatures** under certain conditions. Please contact us for more information.

Suitable hose materials/types

Plastic pipes	PE, PA, or PUR pipe materials that match the tolerances (see below). For soft and thin-walled pipes, we generally recommend the use of support sleeves and verification of the pressure ranges of the pipe material used. (Please do not hesitate to contact us).
Metal pipes (soft)	Brass, copper, aluminium pipes that match the tolerances (see below).
Metal pipes (hard) or surface-treated	Please check the suitability of the connectors in advance. Please do not hesitate to contact us.

It is absolutely essential that the outer diameter of the pipe is free from damage or longitudinal grooves.

Installation

All pipes and connectors must be clean and undamaged before use. Make sure that the pipe surface is free from longitudinal grooves, dents, or similar signs of damage.

Pipe tolerances

Our connectors can be used with the following tube diameters and tolerances.

Pipe outer diameter (mm)	Ø 15 mm - 28 mm
Tolerances (mm)	+0.05/-0.10

Installation and system test

All pipes and connectors must be clean and intact before use. After the installation, all hose and connector installations must be pressure tested to ensure that the system is pressure-tight before it is delivered to the customer.

Please also refer to: "Connecting".

Testing the system

No matter whether you are working on a new or an existing system, we recommend testing the system as follows before use:

- ▶ Test the system at an operating pressure of 10 bar for a period of 10 minutes.
- ▶ Relieve the pressure on the system to 0 bar.
- ▶ Then, subsequently test the system at a working pressure of 2 bar for a period of 10 minutes.

Liquid chemicals

If you will be using chemicals or other potentially aggressive liquids, please contact us.

Caution: Our connectors are not designed for use with explosive gas, paraffin and other fuels.

Protective caps

Protective caps are available as an additional safeguard against the hose slipping out or for protection (marking) for differentiation by colour (see accessories on the following pages).

Food resistance

All connectors illustrated in this catalogue comply with foodstuff directives and can thus be used in food applications without any problems.

Maximum torque values for BSP plastic thread

	Threading	Threading	Threading
Thread size	3/8" – 1/2"	3/4"	1"
Max. torque	3.0 Nm	4.0 Nm	5.0 Nm

Maximum torque values for metal threads BSPT, BSP

	Threading	Threading	Threading
Thread size	1/2"	3/4"	1"
Max. torque	4.0 Nm*	5.0 Nm*	7.0 Nm*

*These values can vary.

The values depend on the thread sealing material.

We recommend testing all installations before use to ensure that the installation has been correctly completed. Leak tightness must also be tested.

The maximum torque is geared to the use of our connectors and refers to types used in this catalogue in line with international specifications.

Warranty:

Although we provide a warranty against manufacturing errors and material defects, it is the user's responsibility to ensure that connectors and similar products are suitable for the application in question. The installation must be performed according to our recommendations and pertinent approvals; national standards must be observed.

No leakages must occur at the joints during this period. Sealing plugs and end caps can be useful here to shut off the drain openings and create a tight connection. When our products are integrated into complete systems, we recommend separate tests (functional checks, flow rate checks, chemical resistance, etc.). For safety checks, we additionally recommend documenting the test results in writing.

Compressed air pipe systems - Ø 15-32 mm

Installation instructions for plastic pipelines

To ensure safe and thus correct installation, please observe the following items:

- ▶ Pipe clamps must be installed so as to give the pipe sufficient play to move back and forward
- ▶ The pipe ends must be deburred to avoid damage to the o-rings on the connector
- ▶ Chamfer the pipes to facilitate assembly
- ▶ Cut the pipes with pipe shears RS 28 (Art. no. 215 1528) in order to achieve an optimum cut (90°)
- ▶ To avoid loss of pressure in the system, ensure that pipes always inserted into the connector up to the stop (also note the mark on the connector)
- ▶ When installing a compressed air piping system around a column, please also observe the longitudinal expansion of the pipes and connectors (the recommended distance from the wall is approx. 30 mm)

- ▶ When installing several vertical pipes we recommend first installing the pipe clamps on the horizontal lines, then pressurising the system, and installing the vertical clamps and connectors in a second step. This avoids the vertical pipes slanting after the installation.
- ▶ If there is no refrigeration dryer in the compressed air pipe network, we recommended using our T-connectors with integrated water traps (Art. no. 215 2222). This means that the condensed water can be collected at a defined point.
- ▶ When installing the compressed air pipe network, the thermal expansion must first be correctly computed in order to avoid pipes and connections buckling.

Correction factors for linear expansion

Correction factors for linear expansion of plastic pipes:

Pipe (soft)	Factor 1.5
Pipe (medium)	Factor 1.3
Pipe (hard)	Factor 1.0

Example calculation:

A compressed air line (hard pipe) of 150 m length installed in a factory shop at an ambient temperature of +15 to +40 °C

(ΔT is thus 25 °C) expands by: $\Delta L = 1.0 \times 10^{-4} / ^\circ\text{C} \times 150 \times 25 \text{ }^\circ\text{C}$
 $\Delta L = 0.375 \text{ m}$

The specific linear expansion coefficient (LK) for polyamides = $10^{-4} / ^\circ\text{C}$ is equivalent to 0.1 mm/°C.

Formula for computing linear expansion:

$$\Delta L = \text{factor} \times \text{LK} (10^{-4} / ^\circ\text{C}) \times \text{pipe length (L)} \times \text{temperature } (\Delta T)$$

Easy extension of existing pipe systems

Plug type connectors and pipes tubes can be used to install an independent system or extend or modify an existing pipe network (see right-hand side).

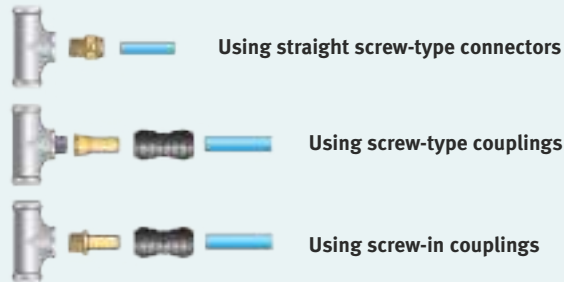

Description of the system water trap

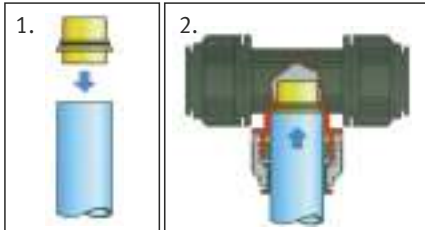

Water trap for 28 mm compressed air line systems
 You can construct a water trap for a 28 mm compressed air network using a standard T-connector, Art. no. 2152828 and brass insert Art. no. 2152829.

1. Push the short part of the insert, Art. no. 2152829 into the plastic or copper pipe.
2. Push the pipe with the insert into the T-piece up to the stop
 The retaining system is doubly secured by twisting the screw cap through a 1/4 turn. This prevents water penetrating into the branch pipes.

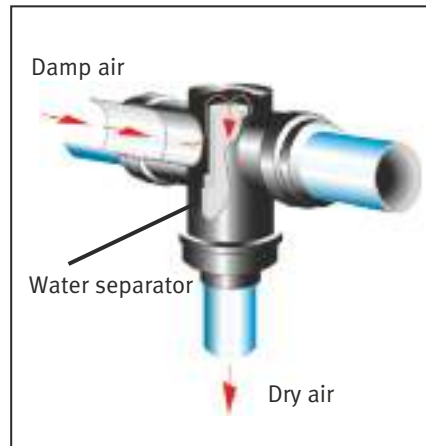

Water trap for 22 mm compressed air line systems
 Water trap T-connectors remove the need for "goose necks" as this sophisticated technology prevents water penetrating into branch pipes. When installing this connector, make sure its is routed horizontally. The connector is marked accordingly to prevent incorrect installation.

Installation notes for aluminium pipes

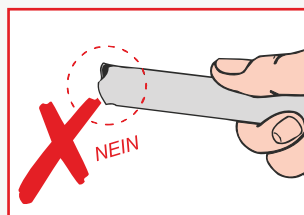
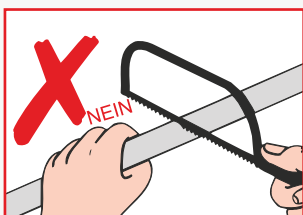

The pipe must be cleanly cut with a pipe cutter! Do not use a saw!

After cutting, deburr the pipe and lightly chamfer. The cutting angle of the aluminium pipe cutter does this for you. This ensures easy insertion of the pipe into the connector.

Compressed air starter kit

Compressed air starter kit	
Plug connection system 15 mm	
Art. no.	
2159901	
25 m PA tube/blue	
15 x angled connectors 15 mm	
4 x T connectors 15 mm	
1 x wall bracket 90° / 15 mm x 1/2" IT	
1 x 3-way air distribution box 1/2"	
1 x screw-in connector 15 mm x 1/2" OT	
50 x hose clamps 15 mm	
50 x circlip 15 mm	



Compressed air starter kit	
Plug connection system 28 mm	
Art. no.	
2159903	
50 m PA tube/blue	
5 x angled connectors 28 mm	
3 x T connectors 28 mm	
1 x screw-in connector 28 mm x 1" OT	
1 x 3-way air distribution box 1/2"	
20 x hose clamps 28 mm	



Compressed air starter kit	
Plug connection system 22 mm	
Art. no.	
2159902	
25 m PA tube/blue	
15 x angled connectors 22 mm	
4 x T connectors 22 mm	
1 x wall bracket 90° / 22 mm x 3/4" IT	
1 x 3-way air distribution box 1/2"	
1 x screw-in connector 22 mm x 3/4" OT	
50 x hose clamps 22 mm	
50 x circlip 22 mm	



Compressed air starter kit	
Plug connection system 22/15 mm	
Art. no.	
2159904	
25 m PA tube/blue	
15 x angled connectors 22 mm	
4 x T connectors 22 mm	
1 x wall bracket 90° / 15 mm x 1/2" IT	
2 x 3-way air distribution box 1/2"	
2 x screw-in connectors 15 mm x 1/2" OT	
30 x hose clamps 22 mm	
20 x hose clamps 15 mm	
10 x circlip 15 mm	
50 x circlip 22 mm	



Plastic pipes for compressed air systems

- ▶ Very smooth inner surfaces, improved flow rate
- ▶ Tried and trusted for years
- ▶ Pressure- and temperature-resistant
- ▶ Vibration- and impact-resistant
- ▶ Corrosion-proof and non-ageing
- ▶ Low weight



Delivery exclusively in the stated PUs!

Operating temperature	
for permanent load	-60 °C to +100 °C (air)
Physical properties	
Material Polyamide 12	
Density at 20 °C	1.04 g/cm ³
Linear expansion coefficient	15·10 ⁻⁵ l/K
Melting point	approx. +160 °C to +170 °C

Roll stock soft

PU/roll	25 m	25 m	25 m	-
Art. no.	215151025	215181725	215221725	-

PU/roll***	100 m	100 m	100 m	50 m
Art. no.	2151510	2151817	2152217	2152824

Technical specifications

Technical specifications	15*	18*	22	28
OD	15*	18*	22	28
ID	12	14	18	23
Wall thickness	1.5 mm	2.0 mm	2.0 mm	2.5 mm
Max. operating pressure** (20 °C)	15 bar	16 bar	14 bar	14 bar
Min. bending radius	90 mm	100 mm	140 mm	190 mm

Utilisation of the permissible operating pressures (sample computation):

Temperature range	+20 °C	+30 °C	+40 °C	+50 °C	+60 °C	+70 °C	+80 °C	+90 °C	+100 °C
Pipe smooth/hard	100%	83%	71%	62%	55%	49%	45%	41%	37%
Example:	Rolls Ø 15 mm (smooth) : Permissible working pressure at +50 °C: 62 % of 15 bar = 9.3 bar								
	Bars Ø 15 mm (hard): Permissible working pressure at +50 °C: 62 % of 25 bar = 15.5 bar								

Pipes hard

PU/bar	3 m	3 m	3 m	3 m
Art. no.	2151511	2151815	2152218	2152823

PU/bunch***	10 x 3 m	10 x 3 m	10 x 3 m	10 x 3 m
-------------	----------	----------	----------	----------

Technical specifications

Technical specifications	15*	18*	22	28
OD	15*	18*	22	28
ID	12	14	18	23
Wall thickness	1.5 mm	2.0 mm	2.0 mm	2.5 mm
Max. operating pressure** (20 °C)	25 bar	28 bar	22 bar	20 bar

* as per DIN 73378 ** Operating pressure with 2.5x safety factor/colour blue

*** Purchase and delivery in PU only (roll/bunch)

Aluminium tubes

AIRCRAFT aluminium pipe is made of aluminium grade ALMgSi 05. Six metre lengths of aluminium pipe are surface coated. The pipes can be used for compressed air and vacuum.

Art. no.	Dim. in mm		Wall thickness in mm	Packaging unit PU	Surface
	OD	ID			
2157315	15	12	1.5	10 x 6 m	grey-coated
2157318	18	15	1.5	10 x 6 m	grey-coated
2157322	22	19	1.5	10 x 6 m	grey-coated
2157328	28	25	1.5	10 x 6 m	grey-coated



Temperature	Pressure
- 20 °C	15 bar
+ 1 °C	15 bar
+ 23 °C	15 bar
+ 70 °C	15 bar

*Diameter from Ø 15 mm to Ø 28 mm, Tube tolerance: ±0.10 mm

Explanation TVPAR:



TVPAR1:
1 – 10 pcs. @ Ø 22 mm



TVPAR1:
1 – 5 pcs. @ Ø 28 mm

Compressed air pipe systems - Ø 15-32 mm

Pipeline building components Ø 15-32 mm

Delivery exclusively in the stated PUs!

Pipe OD	Art. no.	PU
Screw-in connector (parallel thread) up to 10 bar¹⁾		
15	1/2" OT 2151514	10
18	1/2" OT 2151814	10
22	3/4" OT 2152216	10
28	1" OT 2152818	10
32	1" OT 2153232	10
32	1½" OT 2153233	10
Thread sealed by clamped o-ring		
Straight connectors up to 10 bar¹⁾		
15	2150415	10
18	2150418	10
22	2150422	10
28	2150428	5
32	2150432	5
Angled connectors up to 10 bar¹⁾		
15	2150315	5
18	2150318	5
22	2150322	5
28	2150328	5
32	2150332	5
Pluggable reducer/connector up to 10 bar¹⁾		
Fitting	Pipe	Outer diameter
18	15	2151805 10
22	15	2151503 10
22	18	2151804 10
28	22	2152203 10
32	15	2153215 10
32	22	2153222 10
32	28	2153228 10
Straight connectors brass up to 15 bar		
Use of 2156128 only with aluminium pressure line		
15	2156115	1
18	2156118	1
22	2156122	1
28	2156128	1
90° bends brass up to 15 bar		
15	2156215	1
18	2156218	1
22	2156222	1
28	2156228	1
90° bends outer thread brass up to 15 bar		
15	1/2" OT 2156315	1
18	1/2" OT 2156318	1
22	3/4" OT 2156322	1
28	1" OT 2156328	1
T-piece brass up to 15 bar		
15	2156415	1
18	2156418	1
22	2156422	1
28	2156428	1
Screw socket (taper thread) up to 15 bar		
15	1/2" OT 2153415	10
18	1/2" OT 2153422	10
28*	3/4" OT 2153428	10
28*	1" OT 2153429	10
Material brass/*Parallel thread		
Wall plate brass up to 15 bar		
15	1/2" IT 2151500	1
22	3/4" IT 2152200	1

Pipe OD	Art. no.	PU	
Male connector (parallel thread) up to 10 bar¹⁾			
15	1/2" OT 2151512	10	
18	1/2" OT 2151816	10	
22	1/2" OT 2152212	10	
22	3/4" OT 2152234	10	
Thread sealed by clamped o-ring			
T-connector up to 10 bar¹⁾			
15	2150215	5	
18	2150218	5	
22	2150222	5	
28	2152828	5	
32	2150232	5	
T-Reducing connectors up to 10 bar¹⁾			
Pipe OD	Pipe OD	Art. no.	PU
18	15	2153018	5
22	15	2153022	5
Straight reducer-connector			
32	28	2150433	10
Pluggable angled connector up to 10 bar¹⁾			
Pipe OD	Adapter OD	Art. no.	PU
15	15	2151515	10
18	18	2151818	10
22	22	2152322	10
32	32	2153332	10
T-piece with inside thread brass up to 15 bar			
15	1/2" IT 2156515	1	
18	1/2" IT 2156518	1	
22	3/4" IT 2156522	1	
28	1" IT 2156528	1	
End piece with outside thread brass up to 15 bar			
15	1/2" OT 2156615	1	
18	1/2" OT 2156618	1	
22	3/4" OT 2156622	1	
28	1" OT 2156628	1	
End piece with inside thread brass up to 15 bar			
15	1/2" IT 2156715	1	
18	1/2" IT 2156718	1	
22	3/4" IT 2156722	1	
28	1" IT 2156728	1	
Clip removal			
15	2156815	1	
18	2156818	1	
22	2156822	1	
28	2156828	1	
Screw-in connector (taper thread) up to 15 bar			
15	1/2" OT 2151215	10	
22	3/4" OT 2152243	10	
28	1" OT 2152808	10	
Material brass			
Screw-type adapter (parallel thread) brass up to 15 bar			
15	1/2" IT 2151216	10	
22	3/4" IT 2152244	10	
Coupling with outside thread			
for thread			
1/2" OT	2200003	10	
Safety coupling with outside thread			
for thread			
1/2" OT	2203103	10	

¹⁾ Please note when installing plastic connectors: do not use tools, hand tighten only

Delivery exclusively in the stated PUs!

Designation	Art. no.	PU
-------------	----------	----

Wall distribution box - 3 x 1/2" conn. on front for thread Ø		
top bottom		
3/4" Without	2150930	1
3/4" 3/4"	2150931	1
1/2" Without	2150934	1
1/2" 1/2"	2150935	1
Blind plug 1/2"	2150936	1

Material aluminium

Air distribution box plastic - 4 x 1/2" BSP thread		
1/2"	2150212	1

Supplied with three plugs

Air distribution box aluminium - 3 x 1/2" for thread Ø		
1/2" top	2151912	1
3/4" top	2151934	1
1" top	2151910	1

Supplied with two plugs

Plug for thread - Ø		
1/2"	2151901	1

Water trap for pipe OD		
22	2152222	1

Water trap brass for 28 mm T-connector Pipe OD		
28	2152829	1

Pipe clamp for pipe OD		
15	2151520	100
18	2151820	100
22	2152220	100
28	2152820	100
32	2153220	100

Fastener for pipe		
15	2157115	1
18	2157118	1
22	2157122	1
28	2157128	1

Screw clamp with rubber inner belt		
15 - 18	2157218	1
22	2157222	1
28	2157228	1

Protective cap for pipe OD		
15	2150515	10
18	2150518	10
22	2150522	10

Cap for pipe OD		
15	2150815	10
18	2150818	10
22	2150822	10
28	2150828	10
32	2150832	10

Circlip for pipe OD		
15	2150115	10
18	2150118	10
22	2150122	10



Designation	Art. no.	PU
-------------	----------	----

Screw lock		
Medium tight for gap 0.05 - 0.25 mm		
10 g	2500022	25
50 g	2500023	10
250 g	2500024	10

Teflon sealing tape		
12 m length	2500020	10

Designation	Art. no.
-------------	----------

Ball valves		
Type		
R 3/8" IT	3/8" IT	2507710
R 3/8" IT	3/8" OT	2507711
R 1/2" IT	1/2" IT	2507712
R 1/2" IT	1/2" OT with lever	2507713
R 1/2" IT	1/2" OT with knob	2507714
R 3/4" IT	3/4" IT	2507715
R 3/4" IT	3/4" OT	2507716
R 1" IT	1" IT	2507720
R 1" IT	1" OT	2507721
R 1 1/4" IT	1 1/4" IT	2507725
R 1 1/4" IT	1 1/4" OT	2507726
R 1 1/2" IT	1 1/2" IT	2507730
R 1 1/2" IT	1 1/2" OT	2507731
R 2" IT	2" OT	2507741

Air shut-off cocks Ø 15-28 mm		
Consisting of 1 x ball valve and 2 x brass external screw thread end pieces		
End piece		
Pipe OD	Customer	
15	1/2"	2507815
18	1/2"	2507818
22	3/4"	2507822
28	1"	2507828

Compressed air energy saver G1		
Opens and closes automatically, 115 V or 240 VAC operating voltage, 0 °C to +60 °C operating temperature, pressure range 0-16 bar.		
See page 129 for a detailed description		
Energy saver G1, connection: IT 1" 2150001		

Compressed air energy saver G2		
Opens and closes automatically, 115 V or 240 VAC operating voltage, 0 °C to +60 °C operating temperature, pressure range 0-16 bar.		
See page 129 for a detailed description		
Energy saver G2, connection: IT 2" 2150003		

Accessories for compressed air energy saver G1		
Remote control option with 5 m cable		2150002

Aluminium pipe cutter for pipe OD		
4 - 30 mm		2151930

Exterior/interior pipe deburring tool:		
Pipe OD		
Ø 3- 35 mm		2155990

PA pipe shears		
RS 28		2151528
Replacement blade		2151527

Pipe markers (labels)		
Sheet = 3 labels		2156000

Piston compressors

Screw-type compressors

System components

Compressed air maintenance units

Compressed air distribution

Tools

Compressed air distribution blocks - Ø 15-28 mm

Pre-assembled manifolds Ø 15-28 mm for ceiling and wall mounting

- ▶ Universally deployable in your pipe network
- ▶ Air inlet boxes or final distribution boxes
- ▶ Manifolds with filter pressure regulator and oil mist lubricators - perfect in cramped conditions
- ▶ Simple assembly

Air inlet socket with single-handed coupling Ø 15- 28 mm



Scope of delivery:

1 x air distribution box, 2 x plugs 1/2", 1 x end piece OT brass, 1 x coupling 1/2" OT, 1 x sealant

Pipe OD	End piece	Art. no.
15 mm	1/2"	2158515
18 mm	1/2"	2158518
22 mm	3/4"	2158522
28 mm	3/4"	2158528

Distributor box 3 x 1/2" outside thread Ø 15- 22 mm



Scope of delivery:

1 x air distributor box, 1 x end piece OT brass, 1x sealant

Pipe OD	End piece	Art. no.
15 mm	1/2"	2158615
18 mm	1/2"	2158618
22 mm	3/4"	2158622

Junction box with two single-handed couplings Ø 15- 22 mm



Scope of delivery:

1 x air distributor box, 1 x end piece OT brass
1 x plug 1/2", 2 x coupling 1/2" OT, 1x sealant

Pipe OD	End piece	Art. no.
15 mm	1/2"	2158715
18 mm	1/2"	2158718
22 mm	3/4"	2158722

Distribution box with two safety couplings Ø 15- 22 mm



Scope of delivery:

1 x air distributor box, 1 x end piece OT brass
1 x plug 1/2", 2 x coupling 1/2" OT, 1x sealant

Pipe OD	End piece	Art. no.
15 mm	1/2"	2158815
18 mm	1/2"	2158818
22 mm	3/4"	2158822

Junction box with two single-handed couplings Ø 15- 22 mm

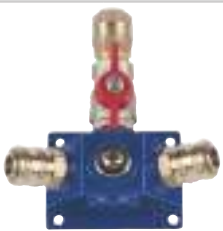

Scope of delivery:

1 x air junction box, 1 x ball valve IT x 1/2" OT,
1 x end piece OT brass, 1 x blind plug 1/2",
2 x coupling 1/2" OT, 1x sealant

Pipe OD	End piece	Art. no.
15 mm	1/2"	2158915
18 mm	1/2"	2158918
22 mm	3/4"	2158922

Distribution box with two safety couplings Ø 15- 22 mm



Scope of delivery:

1 x air distributor box, 1 x end piece OT brass
1 x plug 1/2", 2 x coupling 1/2" OT,
1 x ball valve R 1/2" IT x 1/2" OT, 1x sealant

Pipe OD	End piece	Art. no.
15 mm	1/2"	2159015
18 mm	1/2"	2159018
22 mm	3/4"	2159022

Distribution box with two single-handed couplings, shut-off valve and pressure regulator 12 bar Ø 15 - 22 mm



Scope of delivery:

- 1 x air junction box, 1 x ball valve
- 1 x end piece OT brass, 1 x blind plug 1/2",
- 1 x coupling 1/2" OT, 1 x double nipple T 1/4 x T 1/2,
- 1 x Pressure regulator 1/4" 12 bar, 1 x Safety coupling 1/4" OT

Pipe OD	End piece	Art. no.
15 mm	1/2"	2159115
18 mm	1/2"	2159118
22 mm	3/4"	2159122

Distribution box with two safety couplings, shut-off valve and pressure regulator 12 bar Ø 15 - 22 mm



Scope of delivery:

- 1 x air junction box, 1 x ball valve
- 1 x end piece OT brass, 1 x blind plug 1",
- 1 x coupling 1/2" OT, 1 x double nipple T 1/4 x T 1/2,
- 1 x Pressure regulator 1/4" 12 bar, 1 x Safety coupling 1/4" OT

Pipe OD	End piece	Art. no.
15 mm	1/2"	2159215
18 mm	1/2"	2159218
22 mm	3/4"	2159222

Distribution box with two single-handed couplings, shut-off valve and filter pressure regulator 12 bar Ø 15 - 22 mm



Scope of delivery:

- 1 x air junction box, 1 x ball valve
- 1 x end piece OT brass, 1 x blind plug 1/2",
- 1 x coupling 1/2" OT, 1 x double nipple T 1/4 x T 1/2,
- 1 x filter pressure regulator 1/4", 1 x coupling 1/4" OT

Pipe OD	End piece	Art. no.
15 mm	1/2"	2159315
18 mm	1/2"	2159318
22 mm	3/4"	2159322

Distribution box with two safety couplings, shut-off valve and filter pressure regulator 12 bar Ø 15 - 22 mm

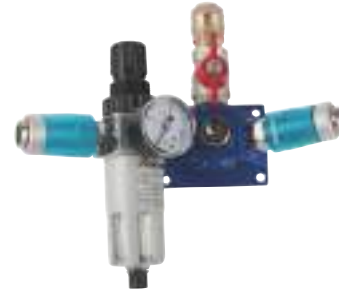

Scope of delivery:

- 1 x air junction box, 1 x ball valve
- 1 x end piece OT brass, 1 x blind plug 1/2",
- 1 x coupling 1/2" OT, 1 x double nipple T 1/4 x T 1/2,
- 1 x filter pressure regulator 1/4", 1 x safety coupling 1/4" OT,

Pipe OD	End piece	Art. no.
15 mm	1/2"	2159415
18 mm	1/2"	2159418
22 mm	3/4"	2159422

Distribution box with two single-handed couplings, shut-off valve and filter pressure regulator and oil mist lubricator 12 bar Ø 15 - 22 mm



Scope of delivery:

- 1 x air junction box, 1 x ball valve
- 1 x end piece OT brass, 1 x blind plug 1/2",
- 1 x coupling 1/2" OT, 1 x double nipple T 1/4 x T 1/2,
- 1 x filter pressure regulator 1/4", 1 x oil mist lubricator 1/4",
- 1 x coupling 1/4" OT, 1 x double nipple T 1/4 x T 1/4,

Pipe OD	End piece	Art. no.
15 mm	1/2"	2159515
18 mm	1/2"	2159518
22 mm	3/4"	2159522

Distribution box with two safety couplings, shut-off valve and filter pressure regulator and oil mist lubricator 12 bar Ø 15 - 22 mm



Scope of delivery:

- 1 x air junction box, 1 x ball valve
- 1 x end piece OT brass, 1 x blind plug 1/2",
- 1 x safety coupling 1/2" OT, 1 x double nipple 1/4" thread x 1/2" thread, 1 x filter pressure regulator 1/4", 1 x mist lubricator 1/4",
- 1 x safety coupling 1/4" OT, 1 x double nipple T 1/4" x T 1/4"

Pipe OD	End piece	Art. no.
15 mm	1/2"	2159615
18 mm	1/2"	2159618
22 mm	3/4"	2159622

Compressed air line systems - aluminium profile Ø 40 - 80 mm

Aluminium profile-compressed air lines 40/50/60/80 mm

The innovative, future-oriented piping system for compressed air and liquids.

- ▶ From the small distribution system to the large-scale industrial production system, Aircraft is the practical and functional solution for compressed air distribution.
- ▶ Aluminium tube combines all advantages of the conventional materials such as steel, plastic or copper, but avoids their disadvantages.
- ▶ On-going enhancements mean up to 50 % time savings compared with legacy systems.
- ▶ Our development target was to remove the need for at least half of the threaded joints for individual components. Only the outer profile shape remained.
- ▶ Diameters 40 mm, 50 mm and 60 mm are available from stock, and up to 80 mm on request.

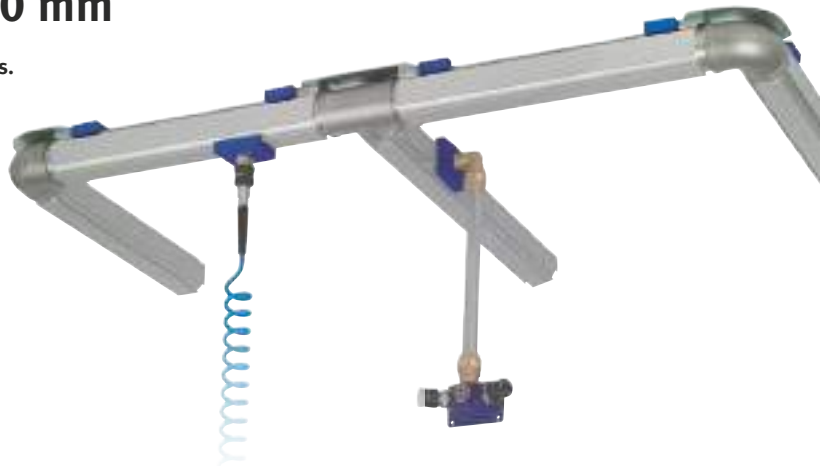

Spot drilling device for fast, low-noise installation of connections.

Patented clamping technology

- ▶ Can be drilled into under pressure
- ▶ Low noise thanks to sound damping
- ▶ Compatible with all systems used worldwide
- ▶ All four sides can be used
- ▶ Rapid and safe installation of connections
- ▶ Easy, fast and cost-efficient installation
- ▶ Air take-off at any required position
- ▶ Variety of fasteners available for wall or ceiling mounting
- ▶ Retroactive changes possible at any time
- ▶ Absolute air tightness and reliability

Tools required for installation:

- ▶ Allen key
- ▶ Deburring knife
- ▶ Conical counterbore
- ▶ Saw (manual saw or electrical cross-cut saw)
- ▶ Grease (Klüber Microlube GL 261 recommended)
- ▶ Drill or cordless screw driver
- ▶ Spot drilling device (if you want to perform spot drilling under pressure in operating conditions)

Compressed air accessories

- ▶ For more details, please turn to page 159



Various dimensions with different internal diameters available, as well as a large range of connection pieces and accessories.



Pre-assembled compressed air connection with safety coupling and spiral hose.

Your benefits

- Lightweight and easy to install
- Very low pressure losses
- No corrosion
- Re-usable
- Fire resistant
- Resistant to ultra-violet radiation
- High impact resistance
- No welding during assembly

Quality

The aluminium compressed air piping system sets new benchmarks in compressed air distribution.

Development

Our development focused on feedback from the market. This means that many processors will recognise their suggestions in the new system.

Flexibility

Air take-off is possible at any required position, even under pressure. Required changes can thus be easily performed within the shortest time.

System

Wherever you need a compressed air system, a single-source, turn-key solution is your guarantee for safety. We help you to implement your needs, from the planning through to commissioning.

Installation

Uncomplicated handling. You only need an Allen key to install.

Output

Turn-key system - with matching components from A to Z in various sizes.

Results

Maximum compressed air quality, a high level of flexibility and time savings due to easy installation make this a forward looking system.

Dimensioning your compressed air lines

Correct dimensioning of a compressed air line is very important: A pressure drop from 6 bar to 5 bar costs approximately 25 % of a tool's performance. To compensate for this pressure drop, around 10% more energy is needed.

Compressor delivery volume	Length in m	25	40	60	80	100	150	200	250	300	400	500	600	800	1000
750	l/min														
1 200		20	20	20	22	22	25	28	28	28	30	30	30	40	40
1 500		20	20	20	22	22	25	28	28	28	30	30	30	40	40
1 500		22	22	25	28	28	30	30	30	40	40	40	40	40	50
2 000		25	28	30	30	40	40	40	40	40	50	50	50	50	50
3 000		30	30	40	40	40	40	50	50	50	50	50	60	60	60
4 800		40	40	40	50	50	50	50	60	60	60	80	80	80	80
7 200		40	50	50	50	60	60	60	80	80	80	80	80	80	80
10 800		50	60	60	60	80	80	80	80	80	80	80	80	80	80

Caution: For closed circular pipelines, halve the total line length. Values are only theoretical and need to be precisely calculated and matched to the situation on site for an individual pipe circuit.

Technical data for aluminium profile piping systems

Application: Compressed air, vacuum, argon, carbon dioxide, hydrogen, petrol, alcohol.

Designations	Profile EL 40, 50, 60, 80
Material	ENAW 6060
Chemical composition	SI 0.3-0.6% Mg 0.35-0.6% Zc 0.1-0.3%
Other designations	DIN: ALMgSi 0.5/F22/ENAW
Heat treatment	Quenching and tempering T66
Surface treatment (on request)	Chemical oxidation colour natural
Specific weight - density	270 kg/dm ³
Electrical conductivity	53 % IACS
Heat conductivity	200 W/m, K
Specific heat	96 J/Kg.K
Expansion coefficient	0.024 mm/m.°C
Brinell hardness	70.4 HB
Tensile strength	215 N/mm ²
Elongation break load	160 N/mm ²
Elastic modulus	6 700 K/mm ²
Elongation A 50 %	6 %
Screw material	Steel grade 8.8
Melt interspace	600 – 650 °C
Min./max. operating temperature	-40 / +120 °C
Test pressure	24 kg/cm ²
Min./max. operating pressure	10 mbar / 15 bar
Material of o-ring seals	NBR 70 Standard
Operating temperature of O-rings	-20 / +100 °C

Pressure drop 0.1 bar at 7 bar working pressure.

Caution: For closed circular pipelines, halve the volume flow and the total length

Aluminium profile compressed air piping system ALS

- ▶ For workshops or smaller industrial enterprises with an air consumption up to max. 2 000 l/min.
- ▶ Perfectly supplements the simplyAir system for branch and delivery pipes. Again, you can benefit from the decisive advantages of our intelligent aluminium piping system
- ▶ Extremely fast and easy installation
- ▶ Aluminium is lightweight, corrosion resistant and supports the flow
- ▶ Air take-off is possible at any required position without interrupting operations
- ▶ Turn-key system with matching components from A to Z in various sizes.
- ▶ Fast modular routing
- ▶ Lines are routed by simply plugging in the pipes
- ▶ Fast installation and removal without any special tools
- ▶ Wide range of connection options and accessories allows for optimum accommodation of the pipe network to workshop conditions
- ▶ Based on a variety of pipe and connection sizes, complete with plates, brackets, or T-pieces

Plate installation



The brilliant design principle eases the assembly. The new pipe network can be easily and quickly installed.

All thanks to our superior, patent-registered clamping technology. This helps you make genuine savings in terms of both time and money. The heart of this

innovative piping system is a lightweight rectangular tube made of extruded aluminium.

Excellent corrosion resistance and flow support. Aluminium combines all the benefits of conventional materials such as steel, plastic or copper. At the same time it avoids their disadvantages such as a rough surface, sagging tubes, corrosion and the like.

Simply push on the plate, tighten with an Allen key - done!

Compressed air line systems - aluminium profile Ø 40 - 80 mm

Aluminium profile compressed air lines 40/50/60/80 mm



Aluminium pipeline "Natural"			
Pipe Ø ID	Packaging unit PU	Weight per m	Art. no.
40 mm	1 x 6 m	1.0 kg	2154140
50 mm	1 x 6 m	1.4 kg	2154150
60 mm	1 x 6 m	1.9 kg	2154160
80 mm	1 x 6 m	2.6 kg	2154180

Pipe network components Ø 40/50/60/80 mm



Fig. straight connector incl. plates made of stainless steel



Straight connectors - expansion joints complete with stainless steel plates	
Pipe Ø ID	Art. no.
40 mm	2154240
50 mm	2154250
60 mm	2154260
80 mm	2154280

Rubber length compensator	
Pipe Ø ID	Art. no.
40 mm	2157140
50 mm	2157150
60 mm	2157160
80 mm	2157180



Reducing connector, complete with plates	
Pipe Ø ID	Art. no.
50-40 mm	2154350
60-40 mm	2154359
60-50 mm	2154360
80-40 mm	2154379
80-50 mm	2154380
80-60 mm	2154381



Bend 90°, complete with angle plates made of stainless steel	
Pipe Ø ID	Art. no.
40 mm	2154440
50 mm	2154450
60 mm	2154460
80 mm	2154480



Bend 90°, open one side, complete with plates	
Pipe Ø ID	Art. no.
40; 1¼" T	2154441
50; 1½" T	2154451
60; 2" T	2154461
80; 1½" T	2154481



Bend 45°, complete with angle plates made of stainless steel	
Pipe Ø ID	Art. no.
40 mm	2155040
50 mm	2155050
60 mm	2155060
80 mm	2155080



T-connector, complete with plates	
Pipe Ø ID	Art. no.
40 mm	2154540
50 mm	2154550
60 mm	2154560
80 mm	2154580



End piece with outer thread, complete with plates		
Pipe Ø ID	Pipe Ø Customer	Art. no.
40 mm	1"	2155340
40 mm	1 1/4"	2155341
50 mm	1 1/2"	2155350
50 mm	2"	2155351
60 mm	2"	2155360
80 mm	2 1/2"	2155380



Reducing plate complete EL		
Pipe Ø ID		Art. no.
50 mm	40	2155450
60 mm	40	2155460
80 mm	40	2155480
80 mm	50	2155481



End piece closed, complete with plates	
Pipe Ø ID	Art. no.
40 mm	2154940
50 mm	2154950
60 mm	2154960
80 mm	2154980



End piece with inside thread, complete with plates		
Pipe Ø ID	Rohr Ø IT	Art. no.
40 mm	1/2"	2155140
40 mm	1"	2155240
50 mm	1/2"	2155150
50 mm	1"	2155251
50 mm	1 1/4"	2155250
60 mm	1/2"	2155160
60 mm	1"	2155261
60 mm	1 1/2"	2155260
80 mm	1/2"	2155180
80 mm	1"	2155281
80 mm	1 1/2"	2155282
80 mm	2"	2155280



Reducing plate complete ALS		
Pipe Ø ID		Art. no.
40 mm	22	2154022
40 mm	28	2154028
50 mm	22	2155022
50 mm	28	2155028
60 mm	22	2156022
60 mm	28	2156028
80 mm	22	2158022
80 mm	28	2158028



T-connector, open one side		
Pipe Ø ID	Threading	Art. no.
40 mm	1"	2154640
50 mm	1 1/2"	2154650
60 mm	2"	2154660
80 mm	2 1/2"	2154680



Cross connectors	
Pipe Ø ID	Art. no.
40 mm	2154740
50 mm	2154750
60 mm	2154760
80 mm	2154780



Ball valve, complete with plates	
Pipe Ø ID	Art. no.
40 mm	2154840
50 mm	2154850
60 mm	2154860
80 mm	2154880



Baseplate		
Pipe Ø ID		Art. no.
40 mm	3/8"	2155539
40 mm	1/2"	2155540
40 mm	3/4"	2155541
40 mm	1"	2155542
50 mm	3/8"	2155549
50 mm	1/2"	2155550
50 mm	3/4"	2155551
50 mm	1"	2155552
60 mm	3/8"	2155559
60 mm	1/2"	2155560
60 mm	3/4"	2155561
60 mm	1"	2155562
80 mm	3/8"	2155579
80 mm	1/2"	2155580
80 mm	3/4"	2155583
80 mm	1"	2155581
80 mm	1 1/2"	2155582



Baseplate with ball valve 1/2"	
Pipe Ø ID	Art. no.
40 mm	2155640
50 mm	2155650
60 mm	2155660
80 mm	2155680



Ceiling mount with threaded rod complete	
Pipe Ø ID	Art. no.
40 mm	2155840
50 mm	2155850
60 mm	2155860
80 mm	2155880



Universal holder complete with base plate	
Pipe Ø ID	Art. no.
40 mm	2157240
50 mm	2157250
60 mm	2157260
80 mm	2157280



Wall and ceiling mount complete	
Pipe Ø ID	Art. no.
40 mm	2155740
50 mm	2155750
60 mm	2155760
80 mm	2155780



Deburring knife complete	
	Art. no.
150 mm	2155950
Replacement blade	2155951



Taper bore drill	
Drill bit	Art. no.
8-20 mm	2155960



Spot drilling device	
Pipe Ø ID	Art. no.
1/2"	2155940



Metal fixture	
Throat	Art. no.
300 mm	2155930
500 mm	2155935



Hanger bolt	
Dimensions	Art. no.
M8 x 50	2155958
M8 x 60	2155959
M8 x 80	2155961
M8 x 100	2155962
M10 x 100	2155963



Screw insert attachment for electric driving tool	
Dimensions	Art. no.
M8	2155965
M10	2155966



Sealing ring for profile	
Pipe Ø ID	Art. no.
40 mm	2155970
50 mm	2155971
60 mm	2155972
80 mm	2155973



Support clamp M10	
Thickness	Art. no.
0-20 mm	2157100



To make sure that the peripherals around your compressed air lines are exactly what you need, we offer a range of components that perfectly match your system.



Compressed air requirements mean individual requirements and an individual supply - to allow this to happen, the service portfolio must be organised in a smart and flexible way.



Pipes and connections in a variety of sizes form the basis, complete with plates, brackets, or T-pieces.

Pressure regulators/maintenance units

Designation	Art. no.
-------------	----------



Pressure regulator DR 1/4" 12 bar ³⁾	2316050
Pressure gauge Ø 40 mm, 1/8" thread rear	2506440
Pressure regulator DR 1/2" 12 bar ²⁾	2316250
Pressure gauge Ø 40 mm, 1/8" thread rear	2506440

Designation	Art. no.
-------------	----------



Filter pressure regulator FDR 1/4" 12 bar ³⁾	2316000
Replacement vessel filter regulator 1/4"	2316001
Pressure gauge Ø 40 mm, 1/8" thread rear	2506440
Filter pressure regulator FDR 1/2" 12 bar ²⁾	2316200
Replacement vessel filter regulator 1/2"	2316201
Pressure gauge Ø 40 mm, 1/8" thread rear	2506440

Designation	Art. no.
-------------	----------



Oil mist lubricator NÖ 1/4" 12 bar ³⁾	2316060
Replacement vessel lubricator 1/4"	2316061
Oil mist lubricator NÖ 1/2" 12 bar ²⁾	2316260
Replacement vessel lubricator 1/2"	2316261

Designation	Art. no.
-------------	----------



Water trap WA 1/4" 12 bar ³⁾	2316070
Water trap WA 1/2" 12 bar ²⁾	2316270

Designation	Art. no.
-------------	----------



Combined maintenance unit WE 1/4" 12 bar ³⁾	2316080
Combined maintenance unit WE 1/2" 12 bar ²⁾	2316280

1) All 1" models:
Max. inlet pressure: 16 bar
Control range: 0.5 – 14 bar

2) All 1/2" models:
Max. inlet pressure: 16 bar
Control range: 0.5 – 12 bar

3) All 1/4" models:
Max. inlet pressure: 12 bar
Control range: 0.5 – 10 bar

Designation	Art. no.
-------------	----------



Pressure regulator DR 1" 16 bar ¹⁾	2316350
Pressure gauge Ø 40 mm, 1/8" thread rear	2506440

Designation	Art. no.
-------------	----------



Filter pressure regulator FDR 1" 16 bar ¹⁾	2316300
Replacement vessel filter regulator 1"	2316301
Pressure gauge Ø 40 mm, 1/8" thread rear	2506440

Designation	Art. no.
-------------	----------



Oil mist lubricator NÖ 1" 16 bar ¹⁾	2316360
Replacement vessel lubricator 1/2"	2316361

Designation	Art. no.
-------------	----------



Water trap WA 1" 16 bar ¹⁾	2316370
--	---------

Designation	Art. no.
-------------	----------



Fig. shows the scope of delivery Installation example with 1" connection block

Connection block 1" with 2 x 1/2" thread ¹⁾	2316380
Plug for thread 1/2"	2151901

Designation	Art. no.
-------------	----------



Pressure regulator 1/4" 14 bar³⁾	2314050
Pressure gauge Ø 40 mm, 1/8" thread rear	2506440
Pressure regulator 1/2" 14 bar²⁾	2314250
Pressure gauge Ø 40 mm, 1/8" thread rear	2506440

Designation	Art. no.
-------------	----------



Filter pressure regulator 1/4" 14 bar³⁾	2314000
Replacement glass filter 1/4" 14 bar	2314001
Pressure gauge Ø 40 mm, 1/8" thread rear	2506440
Filter pressure regulator 1/2" 14 bar²⁾	2314200
Replacement glass filter 1/2" 14 bar	2314201
Pressure gauge Ø 40 mm, 1/8" thread rear	2506440

Designation	Art. no.
-------------	----------



Oil lubricator 1/4" 14 bar³⁾	2314060
Replacement glass oiler 1/4" 14 bar	2314061
Oil lubricator 1/2" 14 bar²⁾	2314260
Replacement glass oiler 1/2" 14 bar	2314261

Designation	Art. no.
-------------	----------



Water trap 1/4" 14 bar³⁾	2314070
Water trap 1/2" 14 bar²⁾	2314270

Designation	Art. no.
-------------	----------



Maintenance unit 1/4" 14 bar³⁾	2314080
Maintenance unit 1/2" 14 bar²⁾	2314280

1) All 1" models:
Max. inlet pressure: 16 bar
Control range: 0.5 – 14 bar

2) All 1/2" models:
Max. inlet pressure: 16 bar
Control range: 0.5 – 12 bar

3) All 1/4" models:
Max. inlet pressure: 12 bar
Control range: 0.5 – 10 bar

Designation	PU	Art. no.
Couplings with outside thread		
Coupling 1/4" OT	10	2200001
Coupling 3/8" OT	10	2200002
Coupling 1/2" OT	10	2200003
Couplings with inside thread		
Coupling 1/4" IT	10	2200011
Coupling 3/8" IT	10	2200012
Coupling 1/2" IT	10	2200013
Couplings with hose barbs		
Coupling 6 mm	10	2200021
Coupling 9 mm	10	2200022
Coupling 13 mm	10	2200023
Plug-in barb		
Plug-in barb 6 mm	10	2200031
Plug-in barb 9 mm	10	2200032
Plug-in barb 13 mm	10	2200033
Plug-in nipples with outside thread		
Plug-in nipple 1/4" OT	10	2200041
Plug-in nipple 3/8" OT	10	2200042
Plug-in nipple 1/2" OT	10	2200043
Plug-in nipples with inside thread		
Plug-in nipple 1/4" IT	10	2200051
Plug-in nipple 3/8" IT	10	2200052
Plug-in nipple 1/2" IT	10	2200053
Distribution list		
2x 3/8" with coupling	5	2200085
3x 3/8" with coupling	5	2200095
Double hose barbs		
Double hose barbs 6 mm	10	2200102
Double hose barbs 9 mm	10	2200103
Double hose barbs 13 mm	10	2200104
Reducing nipple short		
1/8" IT x 1/4" OT	10	2200141
1/4" IT x 3/8" OT	10	2200142
1/4" IT x 1/2" OT	10	2200143
3/8" IT x 1/2" OT	10	2200145
1/2" IT x 3/4" OT	10	2200147
3/4" IT x 1" OT	10	2200148
Reducing nipple long		
1/4" IT x 1/8" OT	10	2200151
3/8" IT x 1/4" OT	10	2200152
1/2" IT x 3/8" OT	10	2200153
3/4" IT x 1/2" OT	10	2250211
Sleeves		
Sleeves 1/4"	10	2200132
Sleeves 3/8"	10	2200133
Sleeves 1/2"	10	2200134
Sleeves 3/4"	10	2200138
Sleeves 1"	10	2200135
Pivoting connection		
For attachment to compressed air tool · Prevents twisting of the connecting hose · Robust and durable Max. working pressure 12 bar Air connection: 1/4" OT + 1/4" IT		
Pivoting connection	1	2116010
Ear clamps PRO		
for 12.3 mm hose, range: 9.8-12.3 mm	100	2105006
for 13.3 mm hose, range: 10.8-13.3 mm	100	2105008
for 15.7 mm hose, range: 13.2-15.7 mm	100	2105009
for 17.8 mm hose, range: 15.6-17.8 mm	100	2105011
for 19.8 mm hose, range: 16.6-19.8 mm	100	2105012



Designation	PU	Art. no.
T-piece with inside thread		
T-piece 1/8" IT	10	2200190
T-piece 1/4" IT	10	2200193
T-piece 3/8" IT	10	2200196
T-piece 1/2" IT	10	2200199
T-piece with outside thread		
T-piece 1/8" OT	10	2200191
T-piece 1/4" OT	10	2200192
T-piece 3/8" OT	10	2200194
T-piece 1/2" OT	10	2200198
Hose barbs with outside thread		
Threaded barbs 1/8", 4 mm	10	2200171
Threaded barbs 1/8", 6 mm	10	2200172
Threaded barbs 1/8", 9 mm	10	2200173
Threaded barbs 1/4", 6 mm	10	2200174
Threaded barbs 1/4", 9 mm	10	2200176
Threaded barbs 1/4", 13 mm	10	2200181
Threaded barbs 3/8", 6 mm	10	2200175
Threaded barbs 3/8", 9 mm	10	2200177
Threaded barbs 3/8", 13 mm	10	2200182
Threaded barbs 1/2", 6 mm	10	2200178
Threaded barbs 1/2", 9 mm	10	2200179
Threaded barbs 1/2", 13 mm	10	2200180
Angle joint		
Bend 1/8" OT	10	2200201
Bend 1/4" OT	10	2200202
Bend 3/8" OT	10	2200203
Bend 1/2" OT	5	2200204
Blind plug		
Blind plug 1/8"	10	2200211
Blind plug 1/4"	10	2200212
Blind plug 3/8"	10	2200213
Blind plug 1/2"	10	2200214
Galvanized steel dummy plug 1 1/4" - 2 1/2"		
Dummy plug 1 1/4"	1	22511667
Dummy plug 1 1/2"	1	22511668
Dummy plug 2"	1	22511669
Dummy plug 2 1/2"	1	22511671
Double nipple		
Double nipple T 1/8" x T 1/8"	10	2200122
Double nipple T 1/4" x T 1/4"	10	2200123
Double nipple T 1/4" x T 3/8"	10	2200124
Double nipple T 1/4" x T 1/2"	10	2200125
Double nipple T 3/8" x T 3/8"	10	2200126
Double nipple T 3/8" x T 1/2"	10	2200127
Double nipple T 3/8" x T 3/8" left-handed	10	2200130
Double nipple T 1/2" x T 1/2"	10	2200128
Double nipple T 1/2" x T 3/4"	10	2200129
Double nipple T 3/4" x T 3/4"	10	2200136
Double nipple T 3/4" x T 1"	10	2200137
Double nipple detachable		
Double nipple detachable OT 1/8" x 1/8"	10	2200300
Double nipple detachable OT 1/4" x 1/4"	10	2200301
Double nipple detachable OT 3/8" x 3/8"	10	2200302
Double nipple detachable OT 1/2" x 1/2"	10	2200303
Double nipple detachable OT 3/4" x 3/4"	10	2200304
Double nipple detachable OT 1" x 1"	10	2200305



Retail packaging

With cardboard back, packed in packing units



Designation	PU	Art. no.
Couplings with outside thread		
Coupling 1/4" OT	6	2201001
Coupling 3/8" OT K 26	6	2201002
Coupling 1/2" OT	6	2201003

Couplings with inside thread		
Coupling 1/4" IT	6	2201011
Coupling 3/8" IT	6	2201012
Coupling 1/2" IT	6	2201013

Couplings with hose bars		
Coupling 6 mm	6	2201021
Coupling 9 mm	6	2201022
Coupling 13 mm	6	2201023

Plug-in barb		
Plug-in barb 6 mm	6	2201031
Plug-in barb 9 mm	6	2201032
Plug-in barb 13 mm	6	2201033

Plug-in nipples with outside thread		
Plug-in nipple 1/4" OT	6	2201041
Plug-in nipple 3/8" OT	6	2201042
Plug-in nipple 1/2" OT	6	2201043

Plug-in nipples with inside thread		
Plug-in nipple 1/4" IT	6	2201051
Plug-in nipple 3/8" IT	6	2201052
Plug-in nipple 1/2" IT	6	2201053

Distribution list		
2x 3/8" with coupling	6	2201085
3x 3/8" with coupling	6	2201095

Double nipple		
T 1/4" x T 1/4"	6	2201123
T 1/4" x T 3/8"	6	2201124
T 1/4" x T 1/2"	6	2201125
T 3/8" x T 3/8"	6	2201126
T 3/8" x T 1/2"	6	2201127
T 1/2" x T 1/2"	6	2201128

Reducing nipple short IT/OT		
1/8" x 1/4"	6	2201141
1/4" x 3/8"	6	2201142
1/4" x 1/2"	6	2201143
3/8" x 1/2"	6	2201145

Reducing nipple long IT/OT		
3/8" IT x 1/4" OT	6	2201152
1/2" IT x 3/8" OT	6	2201153

Ear clamps PRO		
for 12.3 mm hose, range: 9.8-12.3 mm	4	2105006SB
for 13.3 mm hose, range: 10.8-13.3 mm	4	2105008SB
for 15.7 mm hose, range: 13.2-15.7 mm	4	2105009SB

PU in outer box



One-handed safety couplings

"Comfort" safety couplings

AIRCRAFT is the first manufacturer to use Airprofi series single-handed safety couplings for all compressed air take-off points.



Patented safety

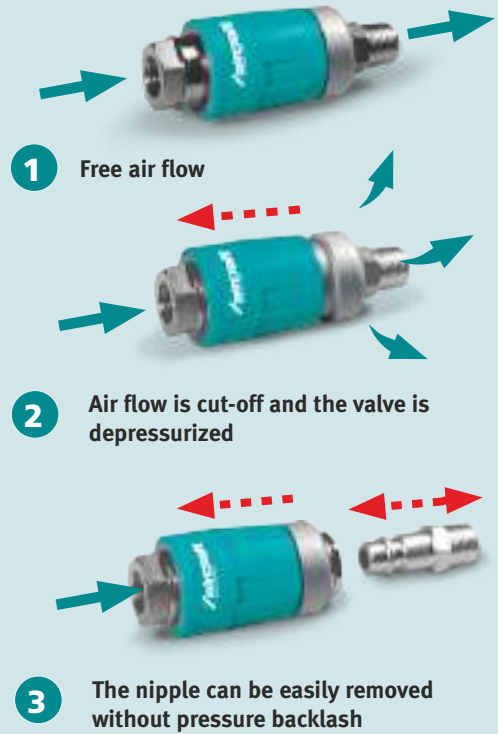

Your benefits at a glance:

Occupational safety

- ▶ No parts and dirt particles are projected out
- ▶ No backlash from the hose line compared with legacy quick-disconnect couplings
- ▶ The system fulfils the requirements in ISO 4414 and is BIA compliant. Increased safety standard at the workplace as a standard!

Very high flow rate

- ▶ The following diagram illustrates the very high flow rate

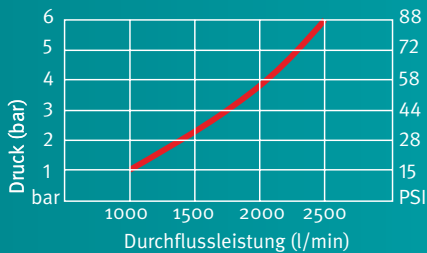

High resistance

- ▶ The plug-in nipple is not exposed to mechanical load; thus brass nipples also last longer

Comfort

- ▶ KOMFORT safety couplings - incomparably easy to use
- ▶ Zero pressure coupling – the nipple can be guided with just two fingers

Universal coupling

- ▶ Usable with plug-in nipple systems from Germany, Switzerland, Italy and the USA

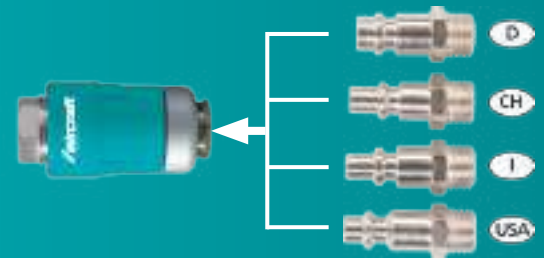

Technical specifications

Temperature	- 15 °C + 80 °C
Plug-in nipple system	German, Swiss, Italian, US
Maximum pressure	20 bar
Weight	approx. 125 g
Throughput at 6 bar	2 500 l/min



Single-handed safety coupling

Type	Art. no.
1/4" outside thread	2203101
3/8" outside thread	2203102
1/2" outside thread	2203103
1/4" inside thread	2203104
3/8" inside thread	2203105
1/2" inside thread	2203106
6 mm with hose barb	2203107
8 mm with hose barb	2203108
10 mm with hose barb	2203109
13 mm with hose barb	2203111



Steel plug-in nipple/steel plug-in barb

Type	Art. no.
1/4" outside thread	2203009
3/8" outside thread	2203010
1/2" outside thread	2203011
1/4" inside thread	2203012
3/8" inside thread	2203013
1/2" inside thread	2203014
Plug-in barb, steel 9 mm	2203015
Plug-in barb, steel 13 mm	2203016

Single-handed safety couplings – Pressure relief and disconnection at the push of a button

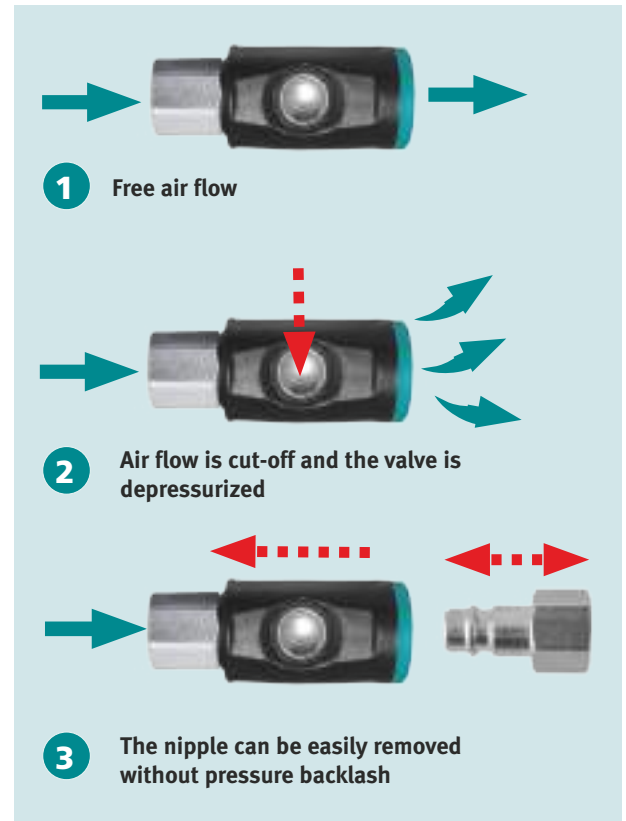
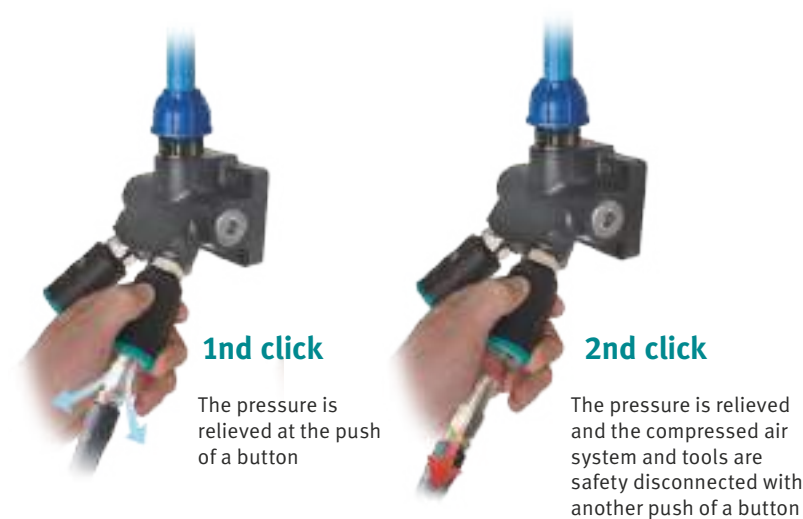

Technical specifications	Single-handed safety coupling
Media/ambient temperature	-20 °C to +70 °C
Plug-in nipple system	7.2 - 7.4 European profile
Maximum pressure	12 bar
Weight	approx. 122 g
Throughput at 6 bar	1 800 l / min
Threaded connection	Nickel-plated brass
Interior parts	Stainless steel 1.4404
Button/Valve	Tempered and galvanised steel
Sealing rings	NBR
Housing outside	Composite material
Housing inside	Anodised aluminium

Your benefits at a glance:

Occupational safety

- ▶ No parts and dirt particles are projected out
- ▶ No backlash from the hose line compared with legacy quick-disconnect couplings
- ▶ The system fulfils the requirements in ISO 4414 and is BIA compliant. Increased safety standard at the workplace as a standard!
- ▶ Very high flow rate
- ▶ Absolute tightness of the couplings and the thread

Economic benefits and stability

- ▶ Long service life of the coupling due to premium workmanship and reduced mechanical load
- ▶ Low energy costs due to long-term leak tightness of the coupling
- ▶ Lightweight, antistatic, scratch-proof material

- ▶ The plug-in nipple is not exposed to mechanical load; thus brass nipples also last longer
- ▶ Resilient to abrasion, impact stress, crushing, vibration and corrosion

Comfort

- ▶ Safety couplings - incomparably easy to use
- ▶ Pressureless coupling
- ▶ Ergonomic, compact shape for intuitive and natural handling
- ▶ The position of the operating button is variably adjustable thanks to the rotating housing
- ▶ Smaller dimensions for less use of space, easy assembly



Coupling with outside thread

Coupling with inside thread

Coupling with hose barb

Single-handed safety coupling

Type	Art. no.
1/4" outside thread	2203520
3/8" outside thread	2203521
1/2" outside thread	2203522
1/4" inside thread	2203523
3/8" inside thread	2203524
1/2" inside thread	2203525
Coupling 6 mm	2203526
Coupling 9 mm	2203527
Coupling 13 mm	2203528



Plug-in nipple OT

Plug-in nipple IT

Plug-in barb

Steel plug-in nipple/steel plug-in barb

Type	Art. no.
1/4" outside thread	2203009
3/8" outside thread	2203010
1/2" outside thread	2203011
1/4" inside thread	2203012
3/8" inside thread	2203013
1/2" inside thread	2203014
Plug-in barb, steel 9 mm	2203015
Plug-in barb, steel 13 mm	2203016

Aircraft Service

Professional Aircraft service - four building blocks for your benefit



Our professional Aircraft customer service gives every customer the ability to choose the performance they need from our comprehensive program of services at any time.

Our services can be divided into the following four modules: inventory and requirements analysis, plant design and advisory

services, installation and commissioning, maintenance and after-sales service.

The AIRCRAFT service field force, and our service partners, ensure reliable, nationwide, on-site service for our customers.

1 Inventory and requirements analysis

Determining your compressed air requirements
Engineering and safety check of your existing system
Energy efficiency measurements of the existing system
Leakage measurements and leak finding for existing systems

3 Installation and commissioning

Installation of your compressed air system
Installing the complete pipe network
Commissioning your compressed air system
Training on site

2 Advisory services and system planning

Planning of your compressed air system
Identifying savings and optimisation potentials
Creating installation drawings
Project management in all phases of the installation

4 Maintenance and repairs

On-site service for repairs and maintenance
Service hotline with professional advisory service
Reminder service for maintenance and testing deadlines
Substitute compressor service



AIRCRAFT Service contacts:



COMPRESSED AIR ADVISORY
SERVICE
AIRCRAFT GERMANY:

Phone: +49 (0) 951 - 96 555-0
Fax: +49 951/96 555 - 55
Email: info@aircraft-kompressoren.de



HOTLINE SPARE PARTS ORDERS
AIRCRAFT GERMANY:

Hotline: Phone +49 (0)951/96 555 - 118 • Fax: (0)951/96 555 - 119
Email: ersatzteile@stuermer-maschinen.de
Direct spare parts availability query: 24h via Partner Portal



SERVICE HOTLINE
(REPAIRS, WARRANTY CLAIMS)

ONLY FOR
SPECIALIST RETAIL
PARTNERS

Phone: +49 (0) 951/96 555 - 100 • Fax: +49 (0) 951/96 555 - 111
Email: service@stuermer-maschinen.de
Fast order processing & status queries: 24h via our Partner Portal

Our specialist retail partners can contact us as follows:
Monday to Thursday: 7 am to 5 pm, Fridays 7 am to 4 pm



COMPRESSED AIR ADVISORY
SERVICE
AIRCRAFT AUSTRIA

Phone: +49 7752 / 70 929 - 0
Fax: +49 7752 / 70 929 - 99
Email: info@aircraft-kompressoren.de



HOTLINE SPARE PARTS ORDERS
AIRCRAFT AUSTRIA:

Phone head office: +49 7752 / 70 929 - 0 • Fax: +49 7752 / 70 929 - 99
Email: ersatzteile@stuermer-maschinen.de
Direct spare parts availability query: 24h via Partner Portal



Compressed air tools and accessories

Coating

Airbrush kit and spray guns

▶ Airbrush complete kit for professionals and demanding hobbyists

▶ Professional paint spraying guns, standard and HVLP type

▶ For perfect coating results in automotive or wood coating applications
▶ Accurate and uniform, excellent coverage

Decoration gun ES

- ▶ Adjustable circular section jet and wide-spread nozzle 0.5 mm
- ▶ With paint volume control
- ▶ Versatile application for car repairs and model making



Model	ES
Art. no.	2101260

Technical specifications	
Plastic gravity feed cup	100 ml
Working pressure	1 - 3 bar
Air consumption	30 - 60 l
Weight	0.40 kg

Accessories	Art. no.
Nozzle set 0.5 mm for ES	2101265
Spare gravity feed cup for ES	2101261

Paint spraying gun SD

- ▶ For universal deployment
- ▶ Continuously adjustable for round and flat jet
- ▶ With paint volume control
- ▶ Plastic gravity feed cup 0.5 l



Model	SD
Art. no.	2101400

Technical specifications	
Plastic gravity feed cup	500 ml
Nozzle	1.5 mm
Working pressure	3.0 - 4.5 bar
Air consumption	100 - 200 l
Weight	0.5 kg

Accessories	Art. no.
Nozzle set 1.5 mm for SD	2101415
Nozzle set 2.0 mm for SD	2101420
Nozzle set 2.5 mm for SD	2101425
Spare gravity feed cup for SD	2101401

Wall mount for paint spraying gun

- ▶ Magnetic table
- ▶ Paint spray gun always at hand



Model	Wall mount
Art. no.	2101010

Technical specifications	
Holding force	4 kg

Air-Brush kit AS

- ▶ Practical single-handed operation for paint and airflow control
- ▶ With paint tanks, 22 ccm and 50 ccm made of glass and 5 ccm made of metal
- ▶ With connecting hose 2 m
- ▶ With gun holder
- ▶ With 1/4" connecting reducer nipple and spanner



Model	Air-Brush kit AS
Art. no.	2101050

Technical specifications	
Weight	16 kg

Accessories	Art. no.
Spare nozzle kit 0.3 mm	2101052

HVLP paint spraying guns

- ▶ Normal pressure spray gun HVLP system; lower atomisation pressure reduces backlash and spray mist
- ▶ Lower air consumption
- ▶ Lower paint consumption
- ▶ More effective coverage
- ▶ Reduces disposal costs for overspray and filter



legacy principle



HIGH VOLUME
LOW PRESSURE

Paint spraying gun PJ HVLP

- ▶ For premium applications
- ▶ With continuously adjustable material and airflow control
- ▶ Plastic gravity feed cup with drip protector
- ▶ With paint strainer

Model	PJ HVLP
Art. no.	2101600

Technical specifications	
Plastic gravity feed cup	750 ml
Nozzle	1.4 mm
Working pressure	3.5 - 4 bar
Air consumption	150 - 200 l
Weight	0.7 kg

Accessories	Art. no.
Nozzle set 1.4 mm	2101614
Nozzle set 1.7 mm	2101617
Nozzle set 2.0 mm	2101620
Nozzle set 2.2 mm	2101622
Spare gravity feed cup 0.75 l	2101601
Paint filter	2101602



Paint spraying gun HVLP-2 PRO

- ▶ For professional use
- ▶ Continuously adjustable for round and wide jet
- ▶ With continuously adjustable paint volume and airflow control
- ▶ In practical storage cases with wear parts set, inline pressure regulator and three paint filters



Model	HVLP-2 PRO
Art. no.	2101740

Technical specifications	
Plastic gravity feed cup	680 ml
Nozzle	1.5 mm
Working pressure	2 - 2.5 bar
Air consumption	220 - 260 l/min
Weight	0.547 kg

Accessories	Art. no.
Nozzle set 1.3 mm	2101750
Nozzle set 1.5 mm	2101751
Nozzle set 1.7 mm	2101752
Nozzle set 1.9 mm	2101753
Nozzle set 2.2 mm	2101754
Spare gravity feed cup	2101760
Paint filter (PU10 pcs.)	2101703
repair kit	2101761



Repair kit HVLP-2 PRO



Paint filter
(PU 10 pcs.)

Inline pressure controller with pressure gauge

- ▶ For exact control of the air pressured directly at the gun



Model	Pressure regulator
Art. no.	2101910

Technical specifications	
Thread: Inlet side	1/4" IT
Thread: Outlet side	1/4" OT
Max. inlet pressure	12 bar
Control range	0.5 - 10 bar

Inline water trap

- ▶ For direction connection to the gun
- ▶ Dry air even with long air lines



Model	Water separator
Art. no.	2311900

Technical specifications	
Thread: Inlet side	1/4" IT
Thread: Outlet side	1/4" OT

Funnel spray gun TS PRO

- ▶ For processing roughcast and fibre-based plaster as well as chips, sequins, flock or similar materials with a single gun
- ▶ Also suitable for working on ceilings and floors thanks to 45° angle
- ▶ Miniature ball valve for optimum adaptation of air flow rate to material thickness

Model	TS PRO
Art. no.	2101800

Technical specifications	
Funnel volume	5 l
Nozzle	4.5/6/8/15/18 mm
Working pressure	5 bar
Air consumption	225 l/min
Weight	1.3 kg
Dimensions	250 x 235 x 475 mm

Scope of supply TS PRO	
3 nozzles for plasters (nozzle Ø: 4.5/6.0/8.0 mm)	
2 nozzles for chips (nozzle Ø: 15/18 mm)	
1 45° bend	
1 cannula for chips	

Accessories	Art. no.
Nozzle for plasters Ø 4.5 mm	2101801
Ø 6.0 mm	2101802
Ø 8.0 mm	2101803
Nozzle for chips Ø 15 mm	2101804
Ø 18 mm	2101805
5 l plastic funnel	2101806



Blow cleaning

Blow guns

- ▶ The right blow gun for your application in production, the workshop, for the car or around the home
- ▶ For quick cleaning, even in those hard to reach places

- ▶ Different versions available, tailored to the respective application area
- ▶ PRO models for professional use
- ▶ All blowguns including coupling plug

Blow gun with solid plastic housing:

- ▶ Avoids cold hands thanks to impact-proof plastic body
- ▶ Patented valve technology
- ▶ Infinitely variable control of the air flow thanks to long trigger
- ▶ Low weight

Blow gun short BPK

- ▶ Handy, robust aluminium design



Model	BPK
Art. no.	2112100
PU	10

Technical specifications	
Working pressure	6 bar
Air consumption	150 l/min
Max. inlet pressure	6 bar
Weight	0.18 kg

Blow gun long BPL

- ▶ Handy, robust aluminium design

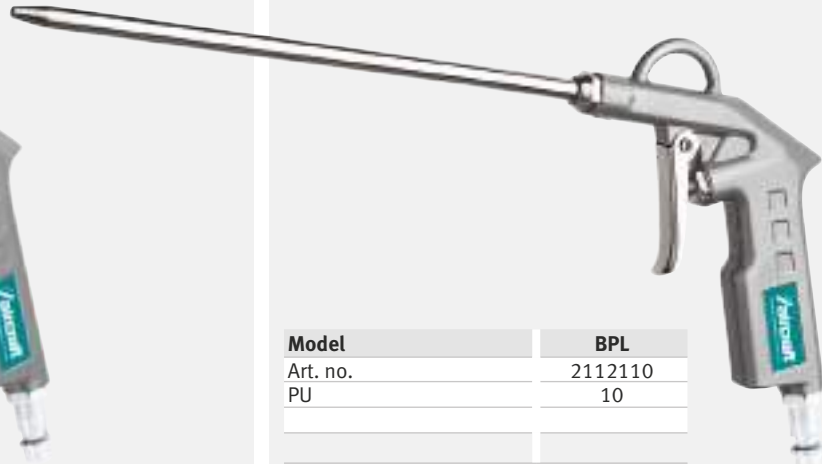

Model	BPL
Art. no.	2112110
PU	10

Technical specifications	
Working pressure	6 bar
Air consumption	150 l/min
Nozzle tube length	160 mm
Nozzle tube outer diameter	6 mm
Max. inlet pressure	6 bar
Weight	0.22 kg

Blow gun BP PRO-E

- ▶ Dosing via anodised trigger
- ▶ Gun shaped out of forged aluminium



Model	BP PRO-E
Art. no.	2102180
PU	5

Technical specifications	
Working pressure	6 bar
Air consumption	150 l/min
Nozzle aperture	1.5 mm
Weight	0.19 kg

Blow gun BPI PRO

- ▶ Injector nozzle with approx. 100 % higher flow rate thanks to Venturi principle



Model	BPI PRO
Art. no.	2102170
PU	5

Technical specifications	
Working pressure	6 bar
Air consumption	150 l/min
Working pressure	1.0 - 6.0 bar
Weight	0.27 kg

Blow gun BP PRO DUO

- ▶ Aluminium body with rubber coating to prevent air flow chill
- ▶ Including interchangeable long nozzle (112 mm) and short nozzle
- ▶ Connection options for the air inlet from the top or bottom for easy connection to the gun and to avoid hose tangle
- ▶ Fine dosing of the air volume via trigger and adjusting screw
- ▶ Long trigger for easy and controlled operation

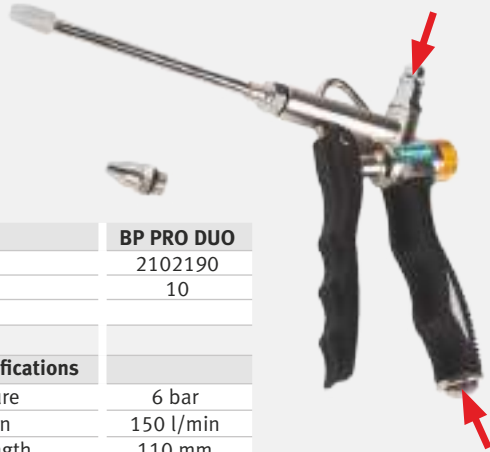

Model	BP PRO DUO
Art. no.	2102190
PU	10

Technical specifications	
Working pressure	6 bar
Air consumption	150 l/min
Nozzle tube length	110 mm
Nozzle tube outer diameter	6 mm
Max. inlet pressure	10 bar
Weight	0.20 kg

- ▶ Hose connection possible at top and bottom
- ▶ No hose tangle

Nozzle set for blow gun, 5-part

- ▶ Adapter, Venturi tube, fan nozzle, ball pumping nozzle, rubber nozzle \varnothing 35 mm
- ▶ Suitable for BP PRO DUO (2102190)



Model	Nozzle set
Art. no.	2102192

Suction/blow gun SBP

- ▶ In a handy plastic case
- ▶ Suitable for vacuuming and blow cleaning surfaces
- ▶ With a flexible, extensible hose



Model	SBP
Art. no.	2102100

Technical specifications	
Air consumption	150 l/min
Working pressure	6.3 bar
Vibration	0.4 m/s ²
Sound pressure level	97 dB(A)
Length	145 mm

Protective shield for blow guns BP PRO

- ▶ Perfect for blowing out blind holes
- ▶ Avoids backlash from swarf, coolant etc.
- ▶ Matches nozzle tube outer diameter 6 mm
- ▶ **Can be used with:**
2102190, 2112120, 2112121, 2112122, 2112127, 2112128, 2112130

Model	Protective shield
Art. no.	2112150
Technical specifications	
External \varnothing	100 mm
Weight	0.03 kg



Rubber nozzles

- ▶ For use with sensitive surfaces
- ▶ Suitable for checking pipes for leaks
- ▶ For pushing onto nozzle pipes with an outside diameter of 6 mm
- ▶ **Can be used with:**
2102190, 2112120, 2112121, 2112122, 2112127, 2112128, 2112130



Model	Rubber nozzle 12 mm	Rubber nozzle 25 mm	Rubber nozzle 35 mm
Art. no.	2112142	2112143	2112144

Technical specifications			
Working pressure	6 bar	6 bar	6 bar
Air consumption	150 l/min	150 l/min	150 l/min
Inlet pressure	11 bar	11 bar	11 bar

Blow gun BPS Soft PRO

- ▶ Handy blow-out gun for easy blow cleaning tasks
- ▶ Activated by slight pressure to the gun tip
- ▶ Air rate adjustable through actuation pressure

Model	BPS Soft PRO
Art. no.	2102130
PU	5



Blow pen BST

- ▶ Rubberised injector protects against surface damage
- ▶ With attachment clip · airflow adjustable by twisting
- ▶ Connects directly to quick coupling
- ▶ Practical compact design

Model	Blow pen BST
Art. no.	2112115

Technical specifications	
Nozzle aperture	2 mm
Air consumption	150 l/min
Working pressure	6 bar
Max. inlet pressure	12 bar



Blow cleaning

Blow guns

- ▶ The right blow gun for your application in production, the workshop, for the car or around the home
- ▶ For quick cleaning, even in those hard to reach places

- ▶ Different versions available, tailored to the respective application area
- ▶ PRO models for professional use
- ▶ All blowguns including coupling plug

Blow gun with solid plastic housing:

- ▶ Avoids cold hands thanks to impact-proof plastic body
- ▶ Patented valve technology
- ▶ Infinitely variable control of the air flow thanks to long trigger
- ▶ Low weight

Blowgun BP PRO V

- ▶ Approx. 100% higher air flow thanks to Venturi nozzle
- ▶ Infinitely variable control of the air flow thanks to long trigger
- ▶ With solid plastic housing



Model	BP PRO V
Art. no.	2112122
PU	5

Technical specifications	
Working pressure	6 bar
Air consumption	150 l/min
Nozzle tube outer diameter	6 mm
Max. inlet pressure	11 bar
Weight	0.15 kg

Blow gun BP PRO SIL

- ▶ With Star-Tip nozzle for ideal vaporisation
- ▶ Noise level 77 dB(A)
- ▶ Meets OSHA standards
- ▶ With solid plastic housing



Model	BP PRO SIL
Art. no.	2112127

Technical specifications	
Working pressure	6 bar
Air consumption	150 l/min
Nozzle tube outer diameter	6 mm
Max. inlet pressure	11 bar
Weight	0.15 kg

Blow gun BP PRO SAFE

- ▶ The output pressure is restricted to under 2 bar upon contact with the surface
- ▶ Reduces the risk of injury
- ▶ With solid plastic housing



Model	BP PRO SAFE
Art. no.	2112128

Technical specifications	
Working pressure	6 bar
Air consumption	150 l/min
Nozzle tube outer diameter	6 mm
Max. inlet pressure	11 bar
Weight	0.14 kg

Blow gun BP PRO

- ▶ For rapid cleaning of large surfaces and those hard to reach places
- ▶ Infinitely variable control of the air flow thanks to long trigger
- ▶ With solid plastic housing
- ▶ Exclusively available as a set of 10 with a practical counter-top display



Model	BP PRO
Art. no.	2112120

Technical specifications	
Working pressure	6 bar
Air consumption	150 l/min
Max. inlet pressure	11 bar
Weight	0.14 kg

Blow gun BP PRO G

- ▶ Perfectly suited for sensitive surfaces
- ▶ Nozzle tip with removable rubber jacket prevents scratches
- ▶ With solid plastic housing



Model	BP PRO G
Art. no.	2112121
PU	5

Technical specifications	
Working pressure	6 bar
Air consumption	150 l/min
Max. inlet pressure	11 bar
Weight	0.14 kg

Blow gun BP PRO R

- ▶ With adjustment screw for setting the maximum airflow
- ▶ Perfectly suited for sensitive surfaces
- ▶ Nozzle tip with removable rubber jacket prevents scratches
- ▶ With solid plastic housing



With adjustment screw

Model	BP PRO R
Art. no.	2112130
PU	5

Technical specifications	
Working pressure	6 bar
Air consumption	150 l/min
Max. inlet pressure	11 bar
Weight	0.14 kg

Blowgun BP PRO EXL – with Venturi, side jet nozzle and 1 000 mm lance

- ▶ Best possible cleaning results also in hard-to-reach places, e.g. for sandwich coolers, with side jet nozzle and robust 1 000 mm lance
- ▶ Venturi nozzle included boosts flow rate by up to 100%
- ▶ Air connection optionally at head or on handle
- ▶ Foam insulated lance for good grip without cold hands

Model	BP PRO EXL*
Art. no.	2102185
Technical specifications	
Air consumption	approx. 150 l/min
Working pressure	6 bar
Max. inlet pressure	10.6 bar
Nozzle tube length	1 000 mm
Nozzle pipe, external diameter	12 mm
Weight	0.462 kg

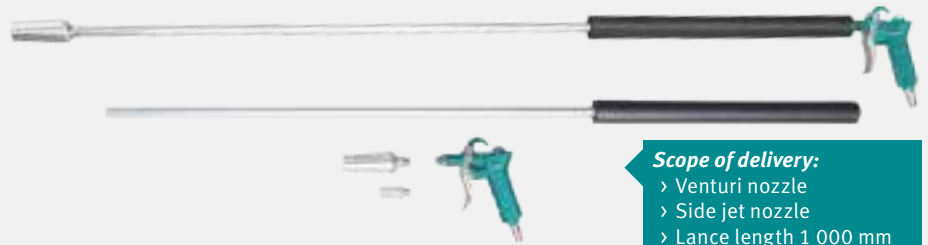

Scope of delivery:

- > Venturi nozzle
- > Side jet nozzle
- > Lance length 1 000 mm

Blow gun BP PRO

- ▶ For hard to reach places
- ▶ With solid plastic housing

Model	BP PRO L	BP PRO XL	BP PRO XXL
Art. no.	2112123	2112124	2112125
PQ	5	5	5
Technical specifications			
Working pressure	6 bar	6 bar	6 bar
Air consumption	150 l/min	150 l/min	150 l/min
Nozzle pipe length	250 mm	500 mm	800 mm
Max. inlet pressure	11 bar	11 bar	11 bar
Weight	0.16 kg	0.18 kg	0.22 kg

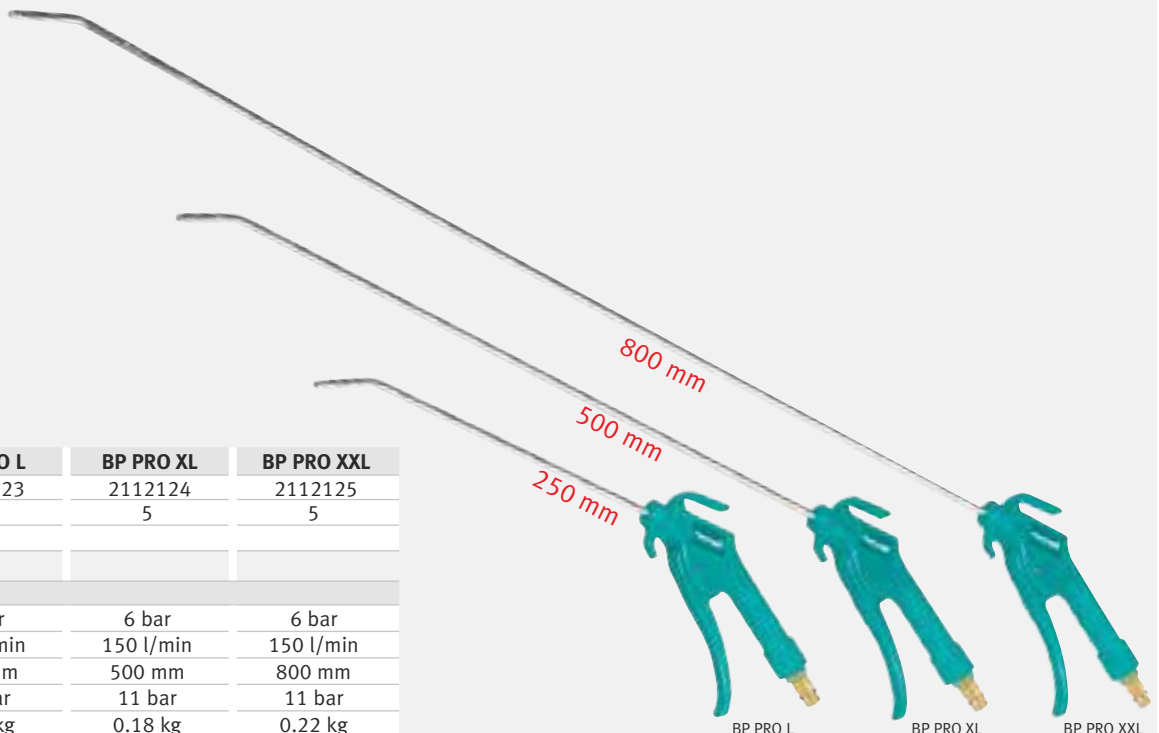

Portable upright inflator/pressure gauge SFM-G

- ▶ The perfect device for mobile tyre inflation service
- ▶ With easy single-handed operation using the "Plus-Minus handle"
- ▶ With inclined, large pressure gauge for optimum readability
- ▶ Offset double-sided filling station connector for all tyre valves with valve thread VT 8 (passenger cars, trucks and motorcycles)
- ▶ Location independent thanks to built-in air tank
- ▶ Automatic refilling when the tank is reattached
- ▶ Air tank with filling valve (approved as gas pressure vessel)
- ▶ Calibrated version
- ▶ Including double-sided connector for filling stations with double connector for twin tyres
- ▶ Excess pressure protected up to 16 bar

Model	SFM-G
Art. no.	2102860

Technical specifications	
Working pressure	max. 10 bar
Air tank capacity	6 l
Filling pressure tank	16 bar
Secondary scale	0 - 140 psi
Operating temperature	-10 to +60 °C
Weight	7.1 kg

Model	Filling valve
Art. no.	2102861

Technical specifications	
Connection	T 1/2"



Filling valve



Calibrated

Easy single-handed operation via "Plus-Minus handle"

Tyre inflation measuring devices / Compressed air kits

Tyre inflator and pressure gauge

- ▶ For checking and inflating tyres
- ▶ Standard and calibrated type

Tyre inflator and pressure gauge

SD/ SD-G

- ▶ With quick coupling
- ▶ SD-G calibrated



SD / SD-G (fig. shows calibrated type SD-G)

Model	SD	SD-G
Art. no.	2102300	2102350

Technical specifications

Working pressure	max. 8 bar	max. 10 bar
Measuring range	0 - 8 bar	0 - 10 bar
Weight	0.39 kg	

Accessories

Accessories	Art. no.
Pressure gauge Ø 63 mm	2102302
Pressure gauge Ø 63 mm, calibration capable	2102351
Compressed air hose 380 mm with quick coupling	2102304
Quick coupling	2102301

RMG Quick-Lock

- ▶ Quick-Lock torque-lock nipple, patented mechanism for secure hold on the valve, as well as quick and easy plugging and unplugging
- ▶ 3-part adapter set included in scope of delivery (bicycle valve adapter, narrow and wide nozzles for balls, inflatable boats, air beds, etc.)



Model	RMG Quick-Lock
Art. no.	2102370

Technical specifications

Max. operating pressure	10 bar
Measuring range	0 - 12 bar
Hose length	410 mm
Pressure gauge Ø	60 mm
Weight	0.35 kg

Tyre inflator and pressure gauge PRO E

- ▶ Suitable for (nitrogen) tyre gas
- ▶ Professional type with rocker arm connector
- ▶ Ergonomically shaped with grip body made of high-strength plastic material
- ▶ High-quality precisely readable pressure gauge



Model	PRO E
Art. no.	2102700

Technical specifications

Max. operating pressure	10 bar
Measuring range	0 - 10 bar
Pressure gauge Ø	63 mm
Weight	0.47 kg

Accessories

Accessories	Art. no.
Pressure gauge Ø 80 mm, calibration capable	2102701
Compressed air hose 500 mm with lever switch	2102702

Tyre inflator and pressure gauge PRO/PRO-G

- ▶ Professional type
- ▶ With quick coupling
- ▶ High-quality precisely readable pressure gauge
- ▶ PRO-G, calibrated



Model	PRO	PRO-G
Art. no.	2102500	2102600

Technical specifications

Working pressure	max. 12 bar	max. 12 bar
Measuring range	0-10 bar	0-10 bar
Pressure gauge Ø	80 mm	80 mm
Weight	0.60 kg	0.58 kg

Accessories

Accessories	Art. no.
Spare pressure gauge Ø 80 mm calibration capable	2102601
Quick coupling	2102301

Tyre inflator and pressure gauge PRO-G COMPACT

- ▶ Calibrated
- ▶ Suitable for (nitrogen) tyre gas
- ▶ Compact professional design, aluminium with lever connector
- ▶ High quality, excess pressure protected gauge with metal housing Ø 63 mm



Model	PRO-G COMPACT
Art. no.	2103010

Technical specifications

Measuring range	0 - 10 bar
Working pressure	max. 10 bar
Weight	0.60 kg

Accessories

Accessories	Art. no.
Pressure gauge Ø 63 mm calibration capable	2103011

Tyre inflator and pressure gauge PRO-G 63

- ▶ Easy inflation and air release with two buttons
- ▶ Calibrated version
- ▶ Easy-to-read 63 mm diameter WIKA pressure gauge
- ▶ Fracture-proof plastic housing
- ▶ Incl. 750 mm rubber hose with car adapter



Model	PRO-G 63
Art. no.	2102870

Technical specifications

Measuring range	0 - 10 bar
Working pressure	max. 10 bar
Weight	0.50 kg

Tyre inflator and pressure gauge PRO-G H / PRO-G DUO

- ▶ Suitable for (nitrogen) tyre gas
- ▶ Particularly robust professional design for filling stations and garages
- ▶ High quality pressure gauge, excess pressure protected in horizontal use position
- ▶ Including double scale manometer for two reading ranges

PRO-G H

- ▶ With lever type connector

PRO-G DUO

- ▶ Universal offset double-sided filling station connector (also for twin-tyres and motorcycle tyres)



Calibrated

PRO-G H



Compressed air hose
2500 mm with lever switch

Model	PRO-G H	PRO-G DUO
Art. no.	2102800	2102850

Technical specifications

Max. operating pressure	10 bar	12 bar
Measuring range	0 – 12 bar	
Pressure gauge Ø	80 mm	
Weight	0.9 kg	1.0 kg

Accessories

Art. no.

Spare pressure gauge Ø 80 mm	2102801
Compressed air hose 2500 mm with lever switch, M20x1	2102804



Calibrated

PRO-G DUO

Twin connector (PU 5)

- ▶ With rubber grip and double-sided plug-in valve



Twin connector

Art. no.	2102605
----------	---------

Technical specifications

Hose barb	6 mm
Weight	0.14 kg

Filling station connector stations PRO DUO

- ▶ Plugs onto lever or torque type connector
- ▶ Curved version



Filling station connector stations PRO DUO

Art. no.	2102803
----------	---------

Lever type connector

- ▶ Including hose clamp and captive valve pins
- ▶ Hose barb 6 mm



Lever type connector

Art. no.	2102802
----------	---------

Adapter kit (PU 10)

- ▶ Bicycle valve adapter, narrow nozzle, wide nozzle for bicycles, balls, inflatable boats, air beds



Adapter kit (PU 10)

Art. no.	2102900
----------	---------

TVS PRO Turbo valve connector

- ▶ For up to 50% time savings
- ▶ Easy plugging in thanks to quick coupling
- ▶ Safe valve removal for faster filling
- ▶ Convenient valve insertion after filling

Model	TVS PRO
Art. no.	2102810

Technical specifications

Length	132 mm
Width/depth	17 mm
Min./max. length	132 - 175 mm
Weight	96 g

Info & video



Compressed air kits

Quality compressed air set entry-level 6-part

- ▶ Consisting of: 1 Blow gun, 1 tyre inflator SD, 1 premium polyurethane spiral hose, 1 3-piece adapter set



Kit 6 pcs.

Model	6-part
Art. no.	2102006

Quality compressed air set 7-part

- ▶ Consisting of: 1 Blow gun short, 1 tyre inflator SD, 1 premium polyurethane spiral hose, 1 3-part adapter set, 1 paint spraying gun



Kit 7 pcs.

Model	7-part
Art. no.	2102007

Quality compressed air set 8-part

- ▶ Consisting of: 1 Blow gun short, 1 tyre inflator SD, 1 premium polyurethane spiral hose, 1 3-piece adapter set, 1 paint spraying gun, 1 spray gun



Kit 8 pcs.

Model	8-part
Art. no.	2102008

Caulking guns/Grease guns/Spray guns

Cartridge guns and silicone applicators

Cartridge gun KP

- ▶ For commercially available cartridges
- ▶ With quick ventilation, no material drips
- ▶ Only works with cartridge
- ▶ Adjust the operating pressure to reflect the material properties

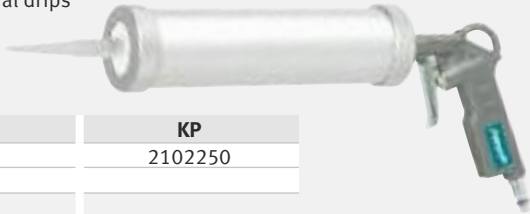

Model	KP
Art. no.	2102250

Technical specifications	
Air consumption	50 l/min
Working pressure	approx. 1.5 - 2.5 bar
Weight	0.5 kg

Cartridge gun KP-R

- ▶ For commercially available cartridges
- ▶ With quick ventilation, no material drips
- ▶ Continuously adjustable for correct dosing of material
- ▶ Cartridge container can be rotated



Model	KP-R
Art. no.	2102260

Technical specifications	
Air consumption	60 l/min
Working pressure	approx. 1.5 - 2.5 bar
Weight	0.56 kg

Cartridge gun KP PRO

- ▶ For commercially available cartridges
- ▶ With quick ventilation, no material drips
- ▶ Continuously variable



Model	KP PRO
Art. no.	2102270

Technical specifications	
Air consumption	100 l/min
Working pressure	8 bar
Weight	1.04 kg

Silicone applicator SP PRO

- ▶ With quick ventilation, no material drips
- ▶ Continuously variable
- ▶ For material bags up to 600 ml



Model	SP PRO
Art. no.	2102290

Technical specifications	
Air consumption	100 l/min
Working pressure	8 bar
Weight	1.32 kg

Spray guns / Underbody protection gun

Spray gun aluminium SPA

- ▶ For spraying cold cleaners, cleaning agents and spray oils
- ▶ With bayonet closure



Model	Alu SPA
Art. no.	2102200

Technical specifications	
Aluminium tank	1 000 ml
Air consumption	200 l/min
Working pressure	4 - 6 bar
Weight	0.46 kg

Accessories	Art. no.
Spare nozzle SPA	2102203

Spray gun aluminium SPA-R

- ▶ For spraying cold cleaners, cleaning agents and spray oils
- ▶ With bayonet closure



Model	SPA-R
Art. no.	2102220

Technical specifications	
Aluminium tank	1 000 ml
Air consumption	120 - 220 l/min
Working pressure	3 - 6 bar
Weight	0.68 kg

Spray gun SPK

- ▶ For spraying cold cleaners, cleaning agents and spray oils
- ▶ With 360° swivelling spray tube
- ▶ Including nozzle Ø 3 mm and adjustable jet



Model	SPK
Art. no.	2103000

Technical specifications	
Plastic tank	700 ml
Air consumption	160 l/min
Working pressure	2 - 6 bar
Weight	0.85 kg

Accessories	Art. no.
Cork seal	2103001



Grease gun kits

Grease gun set FPS PRO

- ▶ For commercially available 400 g DIN cartridges or direct filling
- ▶ Manual type: Pumping of grease due to each actuating of the pull-off
- ▶ With nozzle pipe, flexible hose and hydraulic tip
- ▶ 400 mm connection hose for hard to reach places



Model	FPS PRO
Art. no.	2102230

Technical specifications

Air consumption	0.4 l/Stroke
Working pressure	2 - 8 bar
Pressure ratio	1:40
Weight	1.5 kg

Grease gun kit FPS PRO automatic

- ▶ For commercially available 400 g DIN cartridges or direct filling
- ▶ Automatic type: Grease is pressed out in impacts as long as the pull-off is pushed.
- ▶ 400 mm connection hose for hard to reach places

Automatic



Model	FPS PRO automatic
Art. no.	2102240

Technical specifications

Air consumption	0.4 l/Stroke
Working pressure	2 - 8 bar
Pressure ratio	1:40
Weight	1.6 kg

Grease gun set FPS PRO D

- ▶ For commercially available 400 g DIN cartridges or direct filling
- ▶ Automatic type: Grease is pressed out in impacts as long as the pull-off is pushed.
- ▶ 190 mm connection hose for hard to reach places
- ▶ For hard-to-reach lubrication points, the container can also be rotated through 360°
- ▶ With special bleeder valve: Air inclusions can be bled quickly and easily using this valve

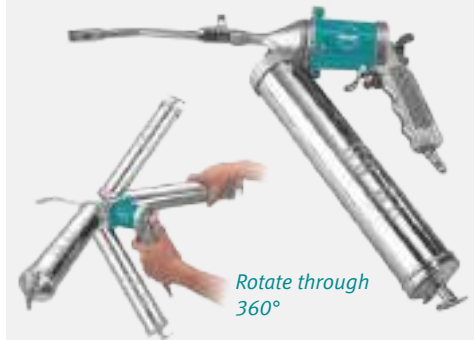

Model	FPS PRO D
Art. no.	2102245

Technical specifications

Air consumption	0.4 l/Stroke
Working pressure	2 - 8 bar
Pressure ratio	1:40
Weight	1.6 kg

Dump valve for grease guns

- ▶ For simple bleeding of grease guns
- ▶ For fast work without interruptions



Model	Art. no.
Dump valve	2102247

Info & video



Cleaning gun RP

- ▶ Cleaning gun for fast, gentle and thorough cleaning of various materials such as fabrics, glass, metal, plastic, painted surfaces...
- ▶ Rotating nozzle type spray gun
- ▶ Wet and dry application possible
- ▶ Atomises the detergent to achieve best effect
- ▶ Continuously adjustable cleaning agent dosing
- ▶ Easy to use



Model	RP
Art. no.	2102210

Technical specifications

Speed	6 000 rpm
Tank volume	900 ml
Working pressure	6.3 bar
Air consumption	approx. 200 l/min
Weight	0.9 kg

Underbody protection gun UHP PRO

- ▶ For underbody and cavity sealing
- ▶ With wide riser tube for viscose material
- ▶ For commercial cans with 40 mm cord thread



Model	UHP PRO
Art. no.	2104150

Technical specifications

Spray hose	550 mm
Working pressure	4 - 6 bar
Air consumption	120 - 180 l
Weight	0.4 kg

Sandblasting guns

Sandblasting guns

Mini sandblasting gun MSP

- ▶ Ideal for spot repairs in automotive applications, refurbishing work in case of stone impact and flash rust
- ▶ Suitable for selective processing of small areas
- ▶ Ideally suited for engraving, roughing and cleaning of various materials such as painted body parts, glass, or plastic surfaces
- ▶ Very gentle on the substrate material

Scope of delivery:
Blasting material tank made of light plastic, 200 g aluminium oxide in plastic container with lid, propellant can adapter with adjusting screw, connector adapter 1/4" IT, 1.5 m air hose for ease of movement



Model	MSP
Art. no.	2103050

Technical specifications	
Air consumption	approx. 200 l/min
Working pressure	2 - 2.5 bar

Accessories	Art. no.
Spare nozzle	2103051
Sandblasting medium	2103053
200 g aluminium oxide in glass	

Sandblasting medium

Sandblasting gun SPB

- ▶ Hardened special nozzle including suction cup 1 l



Model	SPB
Art. no.	2103100

Technical specifications	
Working pressure	4 - 8 bar
Air consumption	250 - 300 l
Nozzle diameter	6 mm
Weight	0.50 kg

Accessories	Art. no.
Spare nozzle	2103101



Spare nozzle

Sand blasting gun SPS

- ▶ Allows suction of abrasive material from external containers



Model	SPS
Art. no.	2103300

Technical specifications	
Working pressure	4 - 8 bar
Air consumption	250 - 400 l/min
Nozzle diameter	6 mm
Weight	0.48 kg

Accessories	Art. no.
Spare nozzle	2103101



Spare nozzle

Sand blasting gun SPS

- ▶ For blasting media up to 0.8 mm grain size
- ▶ Including suction hose, length 170 cm, ID 18 mm / OD 24 mm

Scope of delivery:
Hardened jet nozzle 6 mm



Model	SPS PRO
Art. no.	2103550

Technical specifications	
Working pressure	5 - 8 bar
Air consumption	320 - 420 l/min
Nozzle diameter	6 mm
Weight	1.2 kg

Accessories	Art. no.
Spare nozzle hardened 6 mm	2103551
Spare nozzle hardened 8 mm	2103552



Spare nozzle hardened 8 mm

Professional impact driving tool in lightweight, composite design with powerful torque for car repair shops, builders and trades, industry

Impact driving tool Komposit 1/2" Compact PRO

- ▶ High-performance driving tool with composite housing made of impact-proof plastic material
- ▶ Low-vibration, cold-insulated handle
- ▶ Very lightweight and compact design and maximum power
- ▶ Tightening torque adjustable in 3 stages
- ▶ Exhaust air ducting via handle, prevents brake dust raising
- ▶ For tyre replacement, repairs and assembly work
- ▶ High-performance dual impact mechanism



Starting torque adjustable in 3-stages

Composite 1/2" C



Model	1/2" Compact PRO
Art. no.	2401400

Technical specifications

Air consumption	approx. 420 l/min
Working pressure	6.3 bar
Shank	1/2"
Connection thread	1/4"
Torque	
- Anticlockwise rotation	max. 540 Nm
- CW action	230/360/430 Nm
Weight	1.2 kg

Impact driving tool Komposit 1/2" PRO

- ▶ High-performance driving tool with composite housing made of impact-proof plastic material
- ▶ Low-vibration, cold-insulated handle
- ▶ Very lightweight and compact design and maximum power
- ▶ Tightening torque adjustable in 3 stages
- ▶ Exhaust air ducting via handle, prevents brake dust raising
- ▶ For tyre replacement, repairs and assembly work
- ▶ High-performance dual impact mechanism



Starting torque adjustable in 3-stages

Composite 1/2"



Model	1/2" PRO
Art. no.	2401420

Technical specifications

Air consumption	approx. 408 l/min
Working pressure	6.3 bar
Shank	1/2"
Connection thread	1/4"
Torque	
- Anticlockwise rotation	max. 1 080 Nm
- CW action	245/650/800 Nm
Weight	2.2 kg

Impact driving tool Komposit 3/4" PRO

- ▶ High-performance driving tool with composite housing made of impact-proof plastic material
- ▶ Low-vibration, cold-insulated handle
- ▶ Very lightweight and compact design and maximum power
- ▶ Tightening torque adjustable in 3 stages
- ▶ Exhaust air ducting via handle, prevents brake dust raising
- ▶ For tyre replacement, repairs and assembly work
- ▶ Rugged, durable roller impact mechanism

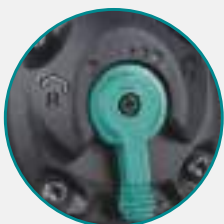

Starting torque 3-stage adjustable

Composite 3/4"



Model	3/4" PRO
Art. no.	2401440

Technical specifications

Air consumption	approx. 510 l/min
Working pressure	6.3 bar
Shank	3/4"
Connection thread	3/8"
Torque	
- Anticlockwise rotation	max. 1 620 Nm
- CW action	338/1 016/1 350 Nm
Weight	3.8 kg

Impact driving tool Komposit 1" PRO

- ▶ High-performance driving tool with composite housing made of impact-proof plastic material
- ▶ Low-vibration, cold-insulated handle
- ▶ Very lightweight and compact design and maximum power
- ▶ Tightening torque adjustable in 3 stages
- ▶ Exhaust air ducting via handle, prevents brake dust raising
- ▶ For tyre replacement, repairs and assembly work
- ▶ Rugged, durable roller impact mechanism
- ▶ 200 mm spindle with handle



Starting torque adjustable in 3-stages

Composite 1"



Model	1" PRO
Art. no.	2401450

Technical specifications

Air consumption	approx. 522 l/min
Working pressure	6.3 bar
Shank	1"
Connection thread	3/8"
Torque	
- Anticlockwise rotation	max. 1 620 Nm
- CW action	338/1 016/1 350 Nm
Weight	5.0 kg

Industrial impact screw driver

Industrial impact driving tool 1/2"

- ▶ Proven standard impact driving tool
- ▶ For tough work in automotive applications, on assembly lines and in agriculture
- ▶ Exhaust air ducting via handle – prevents brake dust raising
- ▶ Low vibration

Industrial impact driving tool 1/2" Super Mini Set

- ▶ Single-handed operation
- ▶ Extremely short design: only 99 mm



Incl. extra short impact driver sockets (14, 15, 16, 17, 19, 21, 22, 24) in a practical plastic case

← only 99 mm →



Model	IS 1/2" Super Mini Set
Art. no.	2401208

Technical specifications

Air consumption	approx. 420 l/min
Working pressure	6.3 bar
Shank	1/2" Square
Connection	1/4"
Torque	
- Anticlockwise rotation	255, 480, 680 Nm
- CW action	250, 470, 610 Nm
Weight	1.4 kg

Torque:
 CCW action: 255, 480, 680 Nm
 CW action: 250, 470, 610 Nm

Industrial impact driving tool IS 1/2" Mini

- ▶ Single-handed operation
- ▶ Composite material – light and cold insulating
- ▶ Very short design
- ▶ Length 120 mm



Model	IS 1/2" Mini
Art. no.	2401213

Technical specifications

Air consumption	approx. 420 l/min
Working pressure	6.3 bar
Shank	1/2" Square
Connection	1/4"
Torque	
- Anticlockwise rotation	max. 850 Nm
- CW action	300, 530, 830 Nm
Weight	1.19 kg

Torque:
 Anti-clockwise rotation: max. 850 Nm
 Clockwise rotation (adjustable in 3-stages) 300, 530, 830 Nm

Industrial impact driving tool IS 1/2" Mini DP

- ▶ Hammer mechanism: Jumbo hammer
- ▶ Easy operation thanks to lateral double throw switch
- ▶ Torque set via adjustment wheel on operating button
- ▶ Rotating air connection – avoids kinking of the air hose
- ▶ Composite material – light and cold insulating
- ▶ Very short design
- ▶ "Soft start" function
- ▶ Hook for fastening on a spring balancer
- ▶ Length 112 mm



Model	IS 1/2" Mini DP
Art. no.	2401362

Technical specifications

Air consumption	approx. 420 l/min
Working pressure	max. 6.3 bar
Shank	1/2" Square
Connection	1/4"
Torque	
- Anticlockwise rotation	678 Nm
- CW action	290, 440, 580 Nm
Weight	1.16 kg

① Lateral double throw switch
 ② Torque set via adjustment wheel on operating button

Industrial impact driving tool IS 1/2" DP

- ▶ Mechanism: Double hammer
- ▶ Easy operation thanks to lateral double throw switch
- ▶ Torque set via adjustment wheel on operating button
- ▶ Rotating air connection – avoids kinking of the air hose
- ▶ Composite material – light and cold insulating
- ▶ "Soft start" function



Model	IS 1/2" DP
Art. no.	2401364

Technical specifications

Air consumption	approx. 450 l/min
Working pressure	max. 6.3 bar
Shank	1/2" Square
Connection	1/4"
Torque	
- Anticlockwise rotation	max. 1085 Nm
- CW action	460, 690, 920 Nm
Weight	2.0 kg

① Lateral double throw switch
 ② Torque set via adjustment wheel on operating button

Industrial impact driving tool IS 3/4" DP

- ▶ Exhaust air ducting via handle – prevents brake dust raising
- ▶ Easy operation thanks to lateral double throw switch
- ▶ Torque set via adjustment wheel on operating button
- ▶ Rotating air connection – avoids kinking of the air hose
- ▶ Composite material – light and cold insulating
- ▶ Low vibration
- ▶ "Soft start" function



Model	IS 3/4" DP
Art. no.	2401366

Technical specifications

Air consumption	approx. 504 l/min
Working pressure	max. 6.3 bar
Shank	3/4" Square
Connection	3/8"
Torque	
- Anticlockwise rotation	max. 1898 Nm
- CW action	815, 1220, 1630 Nm
Weight	3.3 kg

① Lateral double throw switch
 ② Torque set via adjustment wheel on operating button

Industrial impact driving tool IS 1" DP

- ▶ For tough applications in the automotive sector on trucks, buses, for forwarding companies, etc.
- ▶ Exhaust air ducting via handle – prevents brake dust raising
- ▶ Rotating air connection – avoids kinking of the air hose
- ▶ Low vibration
- ▶ Composite material – light and cold insulating
- ▶ "Soft start" function
- ▶ Mechanism: Double hammer



Model	IS 1" DP
Art. no.	2401368

Technical specifications

Air consumption	approx. 504 l/min
Working pressure	max. 6.3 bar
Shank	1" Square
Connection	3/8"
Torque	
- Anticlockwise rotation	max. 1898 Nm
- CW action	815, 1220, 1630 Nm
Weight	3.4 kg

① Lateral double throw switch
 ② Torque set via adjustment wheel on operating button

Industrial impact driving tool 3/4"

- ▶ Proven standard impact driving tool
- ▶ For tough work in automotive applications, on assembly lines and in agriculture

Industrial impact driving tool IS 3/4" Komposit

- ▶ Handy, impact driving tool with impact-proof composite housing
- ▶ With dual-hammer impact mechanism for rapid torque build-up
- ▶ Exhaust air ducting via handle, prevents brake dust raising



Model	IS 3/4" Komposit
Art. no.	2401260

Technical specifications

Air consumption	approx. 510 l/min
Working pressure	max. 6.3 bar
Shank	3/4" Square
Connection	3/8"
Torque	max. 1220 Nm
- Anticlockwise rotation	adjustable in
- CW action	3-stages
Weight	3.2 kg

Industrial impact screw driver IS 3/4" PRO

- ▶ Impact force for clockwise/anti-clockwise rotation separately adjustable in six stages



Model	IS 3/4" PRO
Art. no.	2401250

Technical specifications

Air consumption	approx. 450 l/min
Working pressure	max. 6.3 bar
Shank	3/4" Square
Connection	1/4"
Torque	approx. 1 220 Nm
Weight	5.6 kg

Industrial impact screw driver 1"

- ▶ Proven standard impact driving tool with dual-hammer impact for rapid torque build-up
- ▶ Torque adjustable in three stages for clockwise and anti-clockwise action
- ▶ For tough applications in the automotive sector on trucks, buses, for forwarding companies, etc.

Industrial impact driving tools 1" PRO



Model	IS 1" PRO
Art. no.	2401310

Technical specifications

Air consumption	approx. 570 l/min
Working pressure	max. 6.3 bar
Shank	1" Square
Connection	1/2"
Torque	
- Anticlockwise rotation	3 600 rpm
- CW action	max. 2 800 Nm
Weight	18 kg

Industrial impact driving tools 1" PRO Duo

- ▶ 200 mm spindle
- ▶ Extra-light design



Model	IS 1" PRO Duo
Art. no.	2401350

Technical specifications

Air consumption	approx. 558 l/min
Working pressure	max. 6.3 bar
Shank	1" Square
Connection	1/2"
Torque	3 000 Nm
Weight	10.6 kg

Impact driving tool sets

Impact driving tool sets

Impact driving tool set ISS Komposit 1/2"

- ▶ Handy and lightweight with impact-proof composite housing
- ▶ With dual-hammer impact mechanism for rapid torque build-up
- ▶ Air ducting through the handle

Composite 1/2"



Including ten sockets: 9, 10, 11, 13, 14, 17, 19, 22, 24, 27 mm, extension and inline oiler

Model	ISS 1/2" Komposit
Art. no.	2401220
Technical specifications	
Air consumption	approx. 420 l/min
Working pressure	6.3 bar
Shank	1/2"
Connection	1/4"
Torque	
- Anticlockwise rotation	max. 600 Nm
- CW action	180/560/600 Nm
Weight	2.1 kg



Torque adjustment

Impact driving tool set 1/2" Komposit PRO

- ▶ Lightweight and handy with 4-stage torque adjustment
- ▶ Perfect for loosening tight bolts and glow plugs
- ▶ Tear-off can be avoided to a great extent due to the adjustable torque
- ▶ Single-hand operation for switch-over from anti-clockwise/clockwise rotation
- ▶ Air ducting via cold-insulated, rubber-coated handle

Including ten sockets: 9, 10, 11, 13, 14, 17, 19, 22, 24, 27 mm, extension and inline oiler



Composite

Model	1/2" Komposit PRO
Art. no.	2401430
Technical specifications	
Air consumption	approx. 408 l/min
Working pressure	6.3 bar
Shank	1/2"
Connection	1/4"
Clockwise rotation	245/650/800 Nm
Anticlockwise rotation	max. 1 080 Nm
Weight	2.2 kg

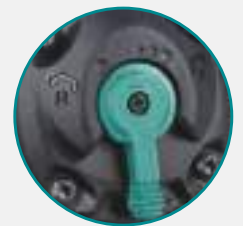

Starting torque adjustable in 3-stages

Impact driving tool set 1/4"

- ▶ Lightweight and handy with 4-stage torque adjustment
- ▶ Perfect for loosening tight bolts and glow plugs
- ▶ Tear-off can be avoided to a great extent due to the adjustable torque
- ▶ Single-hand operation for switch-over from anti-clockwise/clockwise rotation
- ▶ Air ducting via cold-insulated, rubber-coated handle

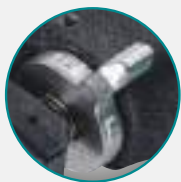

Torque set at CCW/CW control via double throw switch on operating button.



Including 5 long sockets 8, 9, 10, 11, 12 mm, ball joint, extension

Model	Impact driving tool set 1/4"
Art. no.	2401050
Technical specifications	
Air consumption	approx. 300 l/min
Working pressure	6.3 bar
Shank	1/4" Square
Connection	1/4"
Torque	10/20/30/40 Nm
Weight	0.9 kg

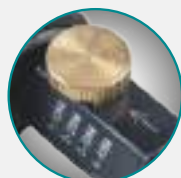

Torque set via adjustment wheel

Impact driving tool set 1/2"

- ▶ Premium impact driving tool with hammer impact mechanism



Including ten sockets: 9, 10, 11, 13, 14, 17, 19, 22, 24, 27 mm, extension and inline oiler

Model	Impact driving tool set 1/2"
Art. no.	2401100
Technical specifications	
Air consumption	approx. 360 l/min
Working pressure	6 bar
Shank	1/2" Square
Connection	1/4"
Torque	320 Nm
Weight	2.2 kg



Torque set via adjustment wheel

Accessories for impact driving tools

Impact driving tool sockets 1/2" long

- ▶ Reinforced type · hardened · in metal box

Impact driving tool socket set 1/2" 10 pcs.

- ▶ Sizes: 10, 11, 12, 13, 15, 17, 19, 21, 22, 24 mm



Model	Impact driving tool socket set 1/2" 10-part
Art. no.	2400001

Impact driving tool sockets 1/2" long

- ▶ Plastic sheathed for alloy wheels
- ▶ Sizes: 17 / 19 / 21 mm
- ▶ Length 85 mm



Model	Impact driving tool sockets 1/2" long
Art. no.	2400010

Impact driving tool sockets 3/4" long

Impact driving tool socket set 3/4" 8 pcs.

- ▶ Sizes: 26, 27, 29, 30, 32, 35, 36, 38 mm



Model	Impact driving tool socket set 3/4" 8-part
Art. no.	2400002

Impact driving tool sockets 1" long

Impact driving tool socket set 1" 7-part

- Sizes: 24, 27, 30, 32, 35, 36, 38 mm



Model	Impact driving tool socket set 1" 7-part
Art. no.	2400003

Inline oiler

- ▶ Connection 1/4" IT/OT



Model	Inline oilers
Art. no.	2310010

Wall mount for impact driving tool

- ▶ Two powerful magnetic holders, holding force 10 kg



Model	Wall mount for impact driving tool
Art. no.	2400050

Wall mount
(Scope of delivery volume without impact driving tool and illustrated impact driving tool sockets)

Drilling machines

Drilling machines

- ▶ Robust industrial type
- ▶ With quick-action drill chuck
- ▶ Lightweight and compact design

Drilling machine BM R+L PRO

- ▶ Air ducting through the handle
- ▶ With anti-clockwise/clockwise rotation switch-over
- ▶ Quick-action drill chuck 3/8", 10 mm

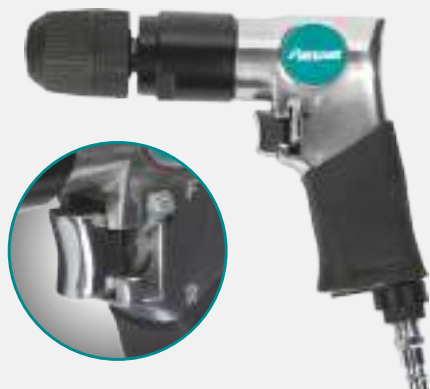

Model	BM R+L PRO
Art. no.	2404100

Technical specifications	
Drilling performance in steel	10 mm
Drilling performance in wood	20 mm
Air consumption	approx. 360 l/min
Working pressure	6 bar
Speed	approx. 1 800 rpm
Connection	1/4"
Weight	1.1 kg

- ▶ With rubberised, ergonomically shaped handle, cold-insulating, slip-proof and low vibration

BM 10 Komposit PRO

- ▶ Quick-action drill chuck 3/8", 1 – 10 mm
- ▶ Powerful dual-transmission for smooth running and a long service life
- ▶ With anti-clockwise/clockwise rotation switch-over



**Composite
Low speed**

Model	BM 10 Komposit PRO
Art. no.	2404150

Technical specifications	
Drilling performance in steel	10 mm
Drilling performance in wood	20 mm
Air consumption	approx. 460 l/min
Working pressure	max. 6.3 bar
Speed	approx. 1 800 rpm
Connection	1/4"
Weight	0.9 kg

- ▶ For production and workshop
- ▶ Composite housing made of impact-proof plastic material

Angle drilling machine WB 10 PRO

- ▶ Quick-action drill chuck 3/8", 10 mm
- ▶ Powerful dual-transmission for smooth running and a long service life



Model	WB 10 PRO
Art. no.	2404190

Technical specifications	
Drilling performance in steel	10 mm
Drilling performance in wood	20 mm
Air consumption	approx. 280 l/min
Working pressure	max. 6.3 bar
Speed	approx. 1 900 rpm
Connection	1/4"
Weight	1.1 kg

Drilling machine BM 13 Komposit PRO

- ▶ Quick-action drill chuck 1/2", 2 – 13 mm
- ▶ Powerful dual-transmission for smooth running and a long service life
- ▶ With anti-clockwise/clockwise rotation switch-over
- ▶ Low speed, thus also suitable for tools with a larger diameter (e.g., stirring tools)



**Composite
Low speed**

Model	BM 13 Komposit PRO
Art. no.	2404170

Technical specifications	
Drilling performance in steel	13 mm
Drilling performance in wood	25 mm
Air consumption	approx. 430 l/min
Working pressure	max. 6.3 bar
Connection	1/4"
Speed	450 rpm
Weight	1.4 kg

Drilling machine BM 13 HT

- ▶ High Performances
- ▶ Handle can be mounted on left or right
- ▶ Stable quick clamping chuck
- ▶ Comfortable cold-insulated handle
- ▶ Low vibration
- ▶ "Soft start" function
- ▶ Square collet:
Quick clamping chuck 2 - 13 mm

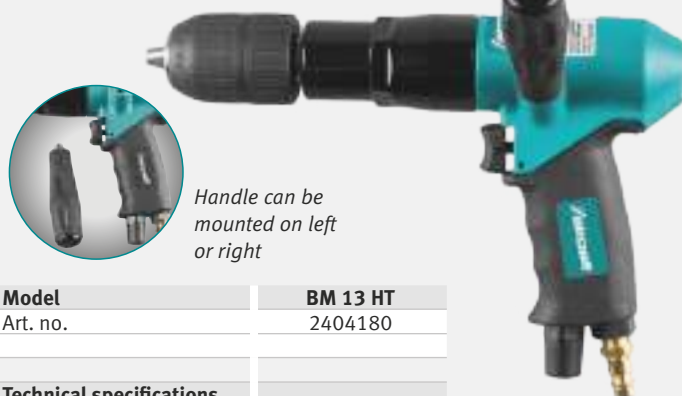

Handle can be mounted on left or right

Model	BM 13 HT
Art. no.	2404180

Technical specifications	
Drilling performance in steel	13 mm
Drilling performance in wood	28 mm
Air consumption	approx. 440 l/min
Working pressure	max. 6.3 bar
Connection	1/4"
Speed	700 rpm
Weight	1.3 kg

Ratchet screwdrivers

▶ Rubber encased ratchet head for working with sensitive materials

▶ Ergonomic, plastic handle, non-slip, low vibration and cold-protection (1/2" models)

▶ Simple adjustment of the sense of rotation at the ratchet head

Ratchet type screwdriver RS 1/4" PRO

▶ Small handy ratchet type screwdriver for tight spaces



Model	RS 1/4" PRO
Art. no.	2401500

Technical specifications

Air consumption	210 l/min
Speed	110 rpm
Torque	33 Nm
Working pressure	max. 6.3 bar
Shank	1/4" Square
Connection	1/4"
Weight	0.5 kg



Ratchet type screwdriver RS 1/2" HT

▶ Very high torque
▶ For hard to reach places
▶ Compact design
▶ High torque thanks to integrated jumbo hammer impact mechanism
▶ Torque control on handle



Model	RS 1/2" HT
Art. no.	2401530

Technical specifications

Air consumption	90 l/min
Speed	110 rpm
Torque	
Anticlockwise rotation	
Clockwise rotation	max. 360 Nm
Working pressure	max. 6.3 bar
Shank	1/2" Square
Connection	1/4"
Weight	2.0 kg

Air ratchet set RS 3/8" PRO

▶ Handy ratchet screwdriver handy for hard to reach places (only 140 mm length) with extensive accessories
▶ With bit socket
▶ Anticlockwise/clockwise rotation



Model	RS 3/8" PRO
Art. no.	2401505

Technical specifications

Air consumption	220 l/min
Speed	110 rpm
Torque	max. 27 Nm
Working pressure	6.3 bar
Shank	3/8"
Connection	1/4"
Weight	0.4 kg

Ratchet type screwdriver Air ratchet set LR S 1/2" RS 1/2" PRO

▶ Very powerful due to double drive in the ratchet head



▶ With rotating connection
▶ With extensive accessories
▶ In a handy plastic case
▶ Anticlockwise/clockwise rotation



Model	RS 1/2" PRO
Art. no.	2401520

Technical specifications

Air consumption	170 l/min
Speed	160 rpm
Torque	approx. 135 Nm
Working pressure	max. 6.3 bar
Shank	1/2" Square
Connection	1/4"
Weight	1.2 kg

Model	LR S 1/2"
Art. no.	2401550

Technical specifications

Air consumption	390 l/min
Speed	160 rpm
Torque	approx. 60 Nm
Working pressure	6 bar
Shank	1/2" Square
Connection	1/4"
Weight	1.2 kg

Ratchet screwdrivers RS W 1/2" PRO

▶ Handy ratchet screwdriver (Length: 256 mm) with +30° to -30° swivel head for working in hard to reach places



Model	RS W 1/2" PRO
Art. no.	2401510

Technical specifications

Air consumption	200 l/min
Speed	180 rpm
Torque	max. 68 Nm
Working pressure	6.3 bar
Shank	1/2" Square
Connection	1/4"
Weight	0.93 kg

Torque wrenches/Angle grinders

Rotary wrenches

- ▶ Clockwise/anti-clockwise rotation with single-handed operation
- ▶ With hexagon socket chuck 1/4"
- ▶ With quick-action chuck
- ▶ Torque configurable via adjusting ring
- ▶ Low-noise thanks to exhaust air hose

Baton screwdriver ST PRO

- ▶ Straight type, ideal for assembly line work

Model	ST PRO
Art. no.	2404210
Technical specifications	
Air consumption	approx. 300 l/min
Speed	1 800 rpm
Torque	3-8 Nm
Working pressure	6.3 bar
Connection	1/4"
Weight	0.9 kg



Pistol type driving tool PS PRO

- ▶ With rubberised handle, cold-insulated and vibration damped

Model	PS PRO
Art. no.	2404220
Technical specifications	
Air consumption	approx. 360 l/min
Speed	1 650 rpm
Torque	1-12 Nm
Working pressure	6.3 bar
Connection	1/4"
Weight	1.7 kg



Angle grinder

- ▶ For commercially available sanding discs up to Ø 125 mm
- ▶ Universally deployable for roughing and cutting

Angle grinder WS 125 PRO

- ▶ Handy and yet powerful model

Model	WS 125 PRO
Art. no.	2403470
Technical specifications	
Air consumption	approx. 490 l/min
Working pressure	6.3 bar
Shank	3/4" Square
Connection	1/4"
Speed	10 000 rpm
Weight	1.7 kg



Industrial angle grinders

- ▶ For commercially available sanding discs up to Ø 125 mm
- ▶ Universally deployable for roughing and cutting
- ▶ Extremely robust design for professional use

Industrial angle grinder IWS 125 PRO

- ▶ With ergonomic plastic handle, non-slip and low vibration
- ▶ With vibration-damping side handle as standard for less fatigue when working
- ▶ With quick change clamping nut and noise-insulation hose as standard
- ▶ With easy-to-use spindle lock
- ▶ Including safety lever to prevent unintentional switching on
- ▶ With practical protective hood adjustment
- ▶ With exhaust air outlet at rear as standard

Model	IWS 125 PRO
Art. no.	2403480

Technical specifications

Air consumption	approx. 560 l/min
Working pressure	6.3 bar
Sanding disc Ø	125 mm
Sanding disc thickness	0.8 - 6 mm
Connection	1/4"
Speed	10 000 rpm
Weight	2 kg



Protective hood quick adjustment



Long neck angle grinder

- ▶ For sanding and grinding also in hard to reach places

Long neck angle grinder TWS PRO

- ▶ With speed control on handle
- ▶ With ergonomic plastic handle, non-slip and low vibration
- ▶ Including safety lever to prevent unintentional switching on
- ▶ With practical protective hood adjustment
- ▶ With air flow regulator in the handle
- ▶ Air outlet at rear

Model	TWS PRO
Art. no.	2403490

Technical specifications

Air consumption	approx. 532 l/min
Working pressure	6.3 bar
Cutting disc Ø	100 mm
Connection	1/4"
Torque	17 000 rpm
Weight	1.8 kg



Protective hood quick adjustment through 126° with eight latching points



Accessories	PQ	Art. no.
Cutting disc	10	2403495
100 mm x 0.8 mm x 9.6 mm		

Long neck angle grinder TWS Super

- ▶ High performance for efficient work
- ▶ Speed control on handle
- ▶ Rotating air exhaust
- ▶ Safety control lever
- ▶ Cold-insulated, non-slip handle
- ▶ Very flat head, only 39 mm
- ▶ Protective hood quick adjustment
- ▶ Spindle detent allows for easy disc replacement
- ▶ Including operating tool
- ▶ For cutting discs 100 x 0.8 x 9.6 mm

Model	TWS Super
Art. no.	2403491

Technical specifications

Air consumption	approx. 480 l/min
Working pressure	6.3 bar
Cutting disc Ø	100 mm
Connection	1/4"
Torque	14 000 rpm
Weight	1.4 kg



Protective hood quick adjustment

Speed control on handle

Accessories	PQ	Art. no.
Cutting disc	10	2403495
100 mm x 0.8 mm x 9.6 mm		

Universal remover

Universal remover set UE PRO

- ▶ For a variety of chassis cleaning tasks
- ▶ Including ergonomic, anti-skid and vibration-damped plastic handle
- ▶ Safety lever
- ▶ Including side handle

Scope of delivery:

- ▶ 1 universal remover UE Pro
- ▶ 1 Carrier wheel 11 mm
- ▶ 1 Carrier wheel 23 mm
- ▶ 1 Wire brush belt fine 11 mm
- ▶ 1 Wire brush belt fine 23 mm
- ▶ 1 Wire brush belt fixed 11 mm
- ▶ 1 Wire brush belt fixed 23 mm
- ▶ 1 Eraser pad ochre

Model	UE PRO
Art. no.	2403800

Technical specifications

Air consumption	approx. 532 l/min
Working pressure	6.3 bar
Connection	1/4"
Speed	3 500 rpm
Weight	1.4 kg



UE PRO

Fig. shows carrier wheel 23 mm with rubber eraser pad, ochre, mounted



Rubber eraser pad ochre



Wire brush belt coarse 23 mm

Accessories included in set



Carrier wheel

Carrier wheel 11 mm

- ▶ For holding wire brush belts of 11 mm width

Carrier wheel 23 mm

- ▶ For holding wire brush belts of 23 mm width and rubber eraser pads



Carrier wheel 11 mm



Carrier wheel 23 mm

Model	Carrier wheel 11 mm	Carrier wheel 23 mm
Art. no.	2403840	2403845

Special carrier wheel

Special carrier wheel for rough cleaning discs - single

- ▶ For one disc

Special carrier wheel for rough cleaning discs - single

- ▶ For two discs



Special carrier wheel for rough cleaning discs - single



Special carrier wheel for rough cleaning discs - single

Model	Special carrier wheel single	Special carrier wheel double
Art. no.	2403860	2403865

Wire brush belts fine

- ▶ Bristles straight, Ø 0.5 mm spring steel
- ▶ For rust removal and cleaning
- ▶ For paint removal



Wire brush belt fine 11 mm



Wire brush belt fine 23 mm

Model	Wire brush belt fine 11 mm	Wire brush belt fine 23 mm
Art. no.	2403820	2403825

Wire brush belts coarse

- ▶ Angled bristles, Ø 0.7 mm spring steel
- ▶ For coarse cleaning work
- ▶ For removing underbody protection and sealing compounds



Wire brush belt coarse 11 mm



Wire brush belt coarse 23 mm

Model	Wire brush belt coarse 11 mm	Wire brush belt coarse 23 mm
Art. no.	2403830	2403835

Rubber eraser disc

Rubber eraser pad ochre

- ▶ For removing films, stickers, adhesive tape, etc.

Rubber eraser disc grey

- ▶ For removing water-soluble paints



Rubber eraser pad ochre



Rubber eraser disc grey

Model	Rubber eraser pad ochre	Rubber eraser disc grey
Art. no.	2403810	2403815

Coarse cleaning disc

- ▶ For removing paints, adhesives and rust
- ▶ Two of these discs are needed for the special double carrier wheel



Coarse cleaning disc

Model	Coarse cleaning disc
Art. no.	2403850

Grinders

▶ Composite design with ergonomic plastic handle, non-slip and low vibration

▶ Compact and handy for working in hard to reach places

▶ Universally deployable for grinding flat and curved surfaces

Delta grinder DS

- ▶ With extraction (4-hole backing pad)
- ▶ For central extraction system

Model	DS
Art. no.	2403500

Technical specifications	
Air consumption	approx. 480 l/min
Working pressure	6.3 bar
Grinding disc	70 x 95 mm
Working stroke	3.2 mm
Connection	1/4"
Speed	11 000 rpm
Weight	0.8 kg



Accessories	PQ	Art. no.
Sandpaper grain size 60	10	2403504
Sandpaper grain size 80	10	2403506
Sandpaper grain size 100	10	2403508
Sandpaper grain size 120	10	2403510
Sandpaper grain size 180	10	2403512

Eccentric grinder ESS 150 Komposit PRO

- ▶ With extraction (6-hole backing pad)
- ▶ Self-extracting

Model	ESS 150 Komposit PRO
Art. no.	2403450

Technical specifications	
Air consumption	approx. 350 l/min
Working pressure	6.3 bar
Bolt circle Ø	80 mm
Sanding disc Ø	150 mm
Working stroke	5 mm
Connection	1/4"
Speed	10 000 rpm
Weight	0.9 kg

Scope of delivery:
▶ Extraction hose
▶ Textile filter bag



Accessories	Art. no.
Grinding disc	2403402

Orbital sander SWS 180 PRO

- ▶ With extraction (8-hole backing pad)
- ▶ Self-extracting
- ▶ Including extraction hose and textile filter bag

Model	SWS 180 PRO
Art. no.	2403520

Technical specifications	
Air consumption	approx. 360 l/min
Working pressure	6.3 bar
Sanding disc Ø	100 x 180 mm
Working stroke	3.2 mm
Connection	1/4"
Speed	8 500 rpm
Weight	1.4 kg



Accessories	PQ	Art. no.
Grinding belt grain size 80	5	2403580
Grinding belt grain size 100	5	2403521
Grinding belt grain size 120	5	2403522
Grinding belt grain size 150	5	2403528

Bidirectional sander BDS PRO

- ▶ File-like linear sanding motion for coarse smoothing
- ▶ For large surface areas in woodworking and bodywork, etc.
- ▶ For sanding wood in the grain direction

Model	BS PRO
Art. no.	2403600

Technical specifications	
Air consumption	approx. 318 l/min
Speed	3 000 rpm
Sanding stroke	25 mm
Sanding surface	65 x 390 mm
Working pressure	max. 6.3 bar
Connection	1/4"
Weight	2.54 kg



Die grinders

Die grinders

- ▶ Lightweight and compact design
- ▶ With ergonomically shaped handle, cold-insulating, low vibration
- ▶ Adjustable exhaust air outlet at rear to prevent dust raising
- ▶ For grinding, deburring, milling and engraving
- ▶ With safety lever and infinitely adjustable speed control

Angle die grinder WST PRO

- ▶ For a variety of chassis cleaning tasks
- ▶ Including ergonomic, anti-skid and vibration-damped plastic handle
- ▶ Speed control on handle
- ▶ Safety lever
- ▶ Including side handle



Model	WST PRO
Art. no.	2403210

Technical specifications	
Air consumption	approx. 330 l/min
Speed	18 000 rpm
Shank	3 mm, 6 mm
Working pressure	6.3 bar
Connection	1/4"
Weight	0.5 kg

Rod grinder ST XL PRO

- ▶ Long form factor, 280 mm overall
- ▶ Speed control on handle



Model	ST XL PRO
Art. no.	2403250

Technical specifications	
Air consumption	approx. 350 l/min
Speed	22 000 rpm
Shank	6 mm
Working pressure	6.3 bar
Connection	1/4"
Weight	0.8 kg

Angle die grinder WST 115

- ▶ Speed control on handle
- ▶ 6 mm + 3 mm collet chuck
- ▶ Rotating air exhaust
- ▶ Safety control lever
- ▶ Cold-insulated, non-slip handle
- ▶ Including operating tool



Model	WST 115
Art. no.	2403215

Technical specifications	
Air consumption	approx. 360 l/min
Speed	18 000 rpm
Shank	3 mm, 6 mm
Working pressure	6.3 bar
Connection	1/4"
Weight	0.7 kg



Speed control on handle

Die grinder set STS PRO

- ▶ Includes two collet chucks (3 mm, 6 mm), five grindstones each (3 mm, 6 mm), plug, and clamping tool in a plastic case



Model	STS PRO
Art. no.	2403200

Technical specifications	
Air consumption	approx. 330 l/min
Speed	22 000 rpm
Shank	3 mm, 6 mm
Working pressure	6.3 bar
Connection	1/4"
Weight	0.6 kg



Die grinder set STS

- Includes two collet chucks (3 mm, 6 mm), five grindstones each (3 mm, 6 mm), plug, and clamping tool in a plastic case



Model	STS
Art. no.	2403190

Technical specifications

Air consumption	approx. 340 l/min
Speed	22 000 rpm
Working pressure	6.3 bar
Connection	1/4"
Weight	0.6 kg

Precision die grinder set PSS PRO

- For grinding, polishing and milling in model, tool and jig making
- Chuck for grinding quills with 3 mm shank



Scope of delivery:

- Ten grinding stones
- Inline oiler
- Tool
- Case

Model	PSS PRO
Art. no.	2403120

Technical specifications

Air consumption	approx. 170 l/min
Speed	54 000 rpm
Working pressure	6.3 bar
Connection	1/4"
Weight	0.2 kg



Accessories	Art. no.
Set of grinding quills	2403121
	10-part

Set of grinding quills

- Comprising five grinding quills each with 3 mm and 6 mm shank



Model	Set of grinding quills
Art. no.	2403150

Abrasive roller and sleeve set

- Consisting of one each roller and abrasive sleeve (shank 6 mm) and one each grinding sleeve with Ø 10/13/19/25/38 mm



Model	Abrasive roller and sleeve set
Art. no.	2403152

Grinding/cutting and punching tools

Belt sander BS PRO

- ▶ 360° swivelling grinding arm for hard to reach areas
- ▶ Automatic clamping device for grinding belt



Accessories	PQ	Art. no.
Grinding belt grain size 80	5	2403708
Grinding belt grain size 120	5	2403712
Grinding belt grain size 180	5	2403718

Model	BS PRO
Art. no.	2403700

Technical specifications	
Air consumption	approx. 400 l/min
Speed	16 000 rpm
Sandpaper	10 x 330 mm
Working pressure	6.3 bar
Connection	1/4"
Weight	0.77 kg

Belt sander BS 20 PRO

- ▶ 360° swivelling grinding arm for hard to reach areas
- ▶ Automatic clamping device for grinding belt



Accessories	PQ	Art. no.
Grinding belt grain size 80	5	2403758
Grinding belt grain size 100	5	2403762

Model	BS 20 PRO
Art. no.	2403750

Technical specifications	
Air consumption	approx. 400 l/min
Speed	17 000 rpm
Sandpaper	20 x 520 mm
Working pressure	6.3 bar
Connection	1/4"
Weight	0.84 kg

Engraving needle GS PRO

- ▶ For marking metal, sheet metals, plastics, stone, marble and other materials with smooth and hard surface



Model	GS PRO
Art. no.	2403110

Technical specifications	
Air consumption	approx. 60 l/min
Working pressure	6.3 bar
Working stroke	1.2 mm
Connection	1/4"
Speed	13 000 rpm
Weight	0.19 kg

Compressed air tools for cutting and punching

- ▶ With a composite housing made of shock-proof plastic for a low weight
- ▶ With ergonomically shaped handle, cold-insulating, low vibration

Sheet nibbler BN PRO

- ▶ For cutting and shaping in bodywork and model building
- ▶ For a tight cutting radius, also in corrugated material
- ▶ For up to 1.6 mm aluminium and 1.2 mm sheet metal



Model	BN PRO
Art. no.	2404550

Technical specifications	
Air consumption	approx. 300 l/min
Stroke speed	2 600 rpm
Cutting width	5 mm
Working pressure	6.3 bar
Connection	1/4"
Weight	1.1 kg

Tin shears

BS Komposit PRO

- ▶ For up to 1.6 mm aluminium and 1.2 mm sheet metal

Composite



Cuts on both sides without bending the material

Model	BS Komposit PRO
Art. no.	2404450

Technical specifications	
Air consumption	approx. 420 l/min
Stroke speed	2 600 rpm
Cutting width	5 mm
Working pressure	6.3 bar
Connection	1/4"
Weight	1.3 kg

Punching and stripping device 2 in 1 LAG PRO

- ▶ For joining sheet metal, for example, in bodywork applications
- ▶ For up to 1.2 mm aluminium and sheet metal
- ▶ For pneumatic-hydraulic punching of 5 mm holes, for example, for spot welding



Model	LAG PRO
Art. no.	2404800

Technical specifications	
Air consumption	0.8 l/Stroke
Cutting width	5 mm
Working pressure	6.3 bar
Connection	1/4"
Weight	1.5 kg

Grinding/Polishing machine PS 7

- ▶ Large angle grinder/polisher with particularly flat head
- ▶ Additional handle for right-handers and left-handers



Replacement plate pad with hook and loop



Replacement plate pad



Polishing disc wool

Model	PS 7
Art. no.	2403290

Technical specifications	
Air consumption	approx. 400 l/min
Idle speed	2 800 rpm
Spindle size	M14 x 2
Hook plate size with hook and loop pad Ø	178 mm
Working pressure	6.3 bar
Connection	1/4"
Weight	2.2 kg

Accessories	Art. no.
Replacement plate 180 mm with hook and loop holder	2403291
Replacement plate pad	2403292
Polishing disc wool	2403294

Mini grinding/polishing machine PSM 3 PRO

- ▶ Handy, small grinder/polisher
- ▶ For repair and polishing work on small areas
- ▶ With continuously variable speed control
- ▶ Air ducting through the handle
- ▶ Plate with hook and loop holder



Foam polishing pad hard



Polishing pad soft



Polishing disc wool

Scope of delivery:

- ▶ Hook and loop pad Ø: 76 mm
- ▶ Polishing pad hard 90 mm
- ▶ Polishing pad soft 90 mm
- ▶ Polishing disc wool 80 mm

Model	Mini PSM 3 PRO
Art. no.	2403280

Technical specifications	
Air consumption	approx. 340 l/min
Idle speed	2 000 rpm
Spindle holder	M 6
Working pressure	6.3 bar
Connection	1/4"
Weight	0.75 kg

Accessories	Art. no.
Polishing pad hard 90 mm	2403281
Polishing pad soft 90 mm	2403282
Polishing disc wool	2403283

Special cutter SZ PRO

- ▶ For cutting out car window glass/adhesive joints
- ▶ With safety lever to prevent unintended switching on
- ▶ Very quiet, thanks to standard exhaust hose
- ▶ Can also be used with sanding pads, diamond cutting discs, scrapers



Model	SZ PRO	Scope of supply with case:
Art. no.	2404850	

- ▶ Blade 37 mm straight standard
- ▶ Blade 47 mm straight offset
- ▶ Blade 48 mm curved offset

Technical specifications	
Air consumption	approx. 280 l/min
Stroke speed	20 000 rpm
Working pressure	6.3 bar
Connection	1/4"
Weight	0.8 kg

Accessories	Art. no.
Blade 37 mm straight standard	2404853
Blade 47 mm straight offset	2404851
Blade 48 mm curved offset	2404852

Accessories SZ PRO



Accessories	Art. no.
Blade 8 mm offset edge	2404865
Blade 18 mm U-shaped curved	2404861
Blade 24 mm U-shaped	2404868
Blade 35 mm straight, serrated	2404866
Blade 36 mm U-shaped curved	2404862
Blade 90 mm U-shaped curved	2404864
Saw blade straight 40 x 33.5 mm 18TPI	2404874
Saw blade tapered 40 x 65 mm 14TPI	2404876
Saw blade circular 81 mm 20TPI	2404870
Saw blade segmented 81 mm 20TPI	2404872
Assembly kit for sanding pad	2404881
Delta sanding pad with hook and loop fastener	2404880
Delta sandpaper with hook and loop fastener 40 grain	2404882
Delta sandpaper with hook and loop fastener 80 grain	2404884
Delta sandpaper with hook and loop fastener 120 grain	2404886

Riveting tools/saws/bodywork repair tools/weld spot milling tools

Riveting tool

Riveting device set NGS

- ▶ In a handy plastic case
- ▶ For automotive, ventilation, facade building, switch cabinet building applications, etc.
- ▶ Uses a variety of rivet holders to handle all commercially available rivets
- ▶ The rivet pins are collected in an accumulator
- ▶ For rivet diameters between 2.4 mm and 4.8 mm



Model	NGS
Art. no.	2404700

- Scope of delivery:**
- ▶ 1 set nozzle-tips
 - ▶ 1 set assembly wrenches
 - ▶ 1 bottle hydraulic fluid
 - ▶ 1 spare parts kit

Technical specifications	
Air consumption	0.8 l/Stroke
Working pressure	6 bar
Connection	1/4"
Weight	1.7 kg

Universal saw

Mini universal saw/file USF mini

- ▶ Handy all-purpose saw/file for use in cramped working conditions
- ▶ For cutting, e.g., plastics, wood, aluminium, and Perspex
- ▶ Ideal for automotive companies, repair shops, body shops, metalworking and sheet metal working
- ▶ Lightweight for easy action
- ▶ Safe guiding due to stop clamp
- ▶ Air ducting to rear through handle
- ▶ Very low noise; includes Silence outlet hose
- ▶ Safe guiding due to stop clamp
- ▶ With safety lever to prevent unintended switching on
- ▶ With a composite housing made of shock-proof plastic for a low weight
- ▶ Cold protection due to rubberised handle



Model	USF mini
Art. no.	2404640

Technical specifications	
Air consumption	approx. 200 l/min
Stroke speed	7 500 rpm
Stroke	10 mm
Cutting thickness in sheet	1.2 mm
Working pressure	6.3 bar
Connection	1/4"
Weight	0.5 kg

- Accessories:**
- Set of files 5-part, Art.no. 2404645
 - Round file
 - ▶ Half-round file
 - ▶ Triangular file
 - ▶ Flat file
 - ▶ Square file

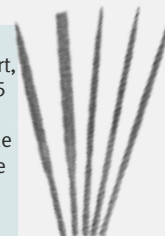

Accessories	Art. no.
File set 5-part, FS5, 4 mm shank	2404645
Bi-metal saw blades KS TPI 18 (PU 3)	2404608
Bi-metal saw blades KS TPI 24 (PU 3)	2404610
Bi-metal saw blades KS TPI 34 (PU 3)	2404614

Compressed air panel-beating hammer

Compressed air panel-beating hammer DBH

- ▶ Compressed air panel-beating hammer for body dent repairs
- ▶ Ideal for bodywork repairs
- ▶ Holds on body through negative pressure after connecting to compressed air system
- ▶ Dent repairs through slight actuation of the hammer

Scope of delivery:

- ▶ Replacement suction cup Ø 60 mm
- ▶ Replacement suction cup Ø 120 mm
- ▶ Replacement suction cup Ø 150 mm
- ▶ Supply hose with ball valve

Model	DBH
Art. no.	2402700

Technical specifications	
Air consumption	approx. 250 l/min
Connection	1/4"
Weight	1.36 kg



Universal saw/file USF PRO

- ▶ Combined device for automotive companies, repair shops, body shops, metalworking and sheet metal working
- ▶ Lightweight for easy action
- ▶ Safe guiding due to stop clamp
- ▶ Cold protection due to rubberised handle
- ▶ Air ducting to rear through handle



Model	USF PRO
Art. no.	2404630

Technical specifications

Air consumption	approx. 200 l/min
Stroke speed	5 000 rpm
Stroke	10 mm
Cutting thickness in sheet	1.6 mm
Working pressure	6.3 bar
Connection	1/4"
Weight	0.75 kg

Accessories:

- Set of files 5-part, Art.no. 2404650
- Round file
- ▶ Half-round file
- ▶ Triangular file
- ▶ Flat file
- ▶ Square file



Accessories	Art. no.
File set 5-part, FS5, 5 mm shank	2404650
Bi-metal saw blades KS TPI 18 (PU 3)	2404608
Bi-metal saw blades KS TPI 24 (PU 3)	2404610
Bi-metal saw blades KS TPI 34 (PU 3)	2404614

Universal saw US Komposit PRO

- ▶ For up to 3.2 mm aluminium and 1.6 mm sheet metal



Model	US Komposit PRO
Art. no.	2404660

Technical specifications

Air consumption	approx. 230 l/min
Stroke speed	10 000 rpm
Stroke	10 mm
Working pressure	6.3 bar
Connection	1/4"
Weight	0.5 kg



With rotary union

Accessories	Art. no.
Bi-metal saw blades KS TPI 18 (PU 3)	2404608
Bi-metal saw blades KS TPI 24 (PU 3)	2404610
Bi-metal saw blades KS TPI 34 (PU 3)	2404614

Needle scalars

- ▶ Ideal for removing rust and paint from wheels, frame parts and in hard to reach places of solid metal parts (not suitable for sheet)
- ▶ Also suitable for tapping off weld slag, paint, plaster and concrete, and for processing stone
- ▶ Long service life thanks to needles made of special steel

Needle scaler NE PRO

- ▶ Small and compact, bar-shaped with twelve individual 3 mm needles
- ▶ Robust full metal housing
- ▶ Quick-action needle replacement without tools by simply opening the guide nozzle

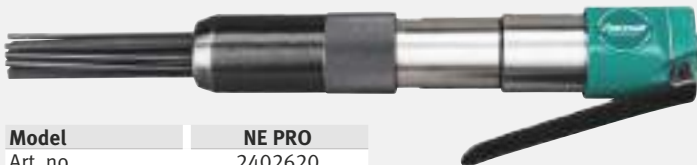

Model	NE PRO
Art. no.	2402620

Technical specifications

Air consumption	approx. 170 l/min
Impact rate	3 800 rpm
Needle length/Ø	125 / 3 mm
Working pressure	6.3 bar
Vibration	16 m/s ²
Connection	1/4"
Weight	1.2 kg

Accessories	Art. no.
Replacement needles	2402625



Needle gun NP PRO

- ▶ Ergonomic handling due to gun shape
- ▶ With 19 individual 3 mm needles
- ▶ Insulated handle and exhaust air ducting to front



Model	NP PRO
Art. no.	2402640

Technical specifications

Air consumption	approx. 170 l/min
Impact rate	3 200 rpm
Needle length/Ø	180 / 3 mm
Working pressure	6.3 bar
Vibration	17 m/s ²
Connection	1/4"
Weight	2.6 kg

Accessories	Art. no.
Replacement needles	2402605



Needle scaler attachment

- ▶ For rough rust removal, weld slag removal, stone working, paint removal, plaster removal, and removal of concrete residues, ...
- Suitable for MHU, MHB PRO and MHV PRO**



Model	Needle scaler attachment
Art. no.	2402600



MHV PRO with needle scaler attachment

Chisel hammer sets

Chisel hammer sets

- ▶ For general purpose use in tile removal, chiselling work, for building site and bodywork applications
- ▶ With ergonomically shaped handle, cold-insulating, low vibration

Chisel hammer drill set MHU

- ▶ For smaller chiselling jobs
- ▶ The hexagonal chuck prevents the chisel twisting.
- ▶ In a handy plastic case



Model	MHU
Art. no.	2402200
Technical specifications	
Air consumption	approx. 280 l/min
Shank	10 mm
Impact rate	3 000 rpm
Working pressure	6.3 bar
Connection thread	1/4"
Weight	1.6 kg

- Scope of delivery:**
- ▶ Chisel hammer drills
 - ▶ Flat chisel
 - ▶ Pointed chisel
 - ▶ Sheet metal cutting chisel
 - ▶ Bolt chisel
 - ▶ Clamping spring
 - ▶ Plug-in nipple 1/4" OT
 - ▶ Oil bottle

Chisel hammer set MHB PRO

- ▶ Long professional type for all work in construction, bodywork applications and electrical installation
- ▶ In a metal case



Model	MHB PRO
Art. no.	2402300
Technical specifications	
Air consumption	approx. 240 l/min
Shank	10 mm
Impact rate	2 200 rpm
Working pressure	6.3 bar
Connection thread	1/4"
Weight	2.0 kg

- Scope of delivery:**
- ▶ Chisel hammer drills
 - ▶ Flat chisel
 - ▶ Pointed chisel
 - ▶ Parting chisel
 - ▶ Wide-flat chisel
 - ▶ Hollow jointing chisel
 - ▶ Clamping spring
 - ▶ Plug-in nipple 1/4" OT

Chisel hammer accessories

Cross recessed holding cover

- ▶ Suitable for MHU, MHB
- ▶ For a rapid chisel change
- ▶ Avoids spring fracture

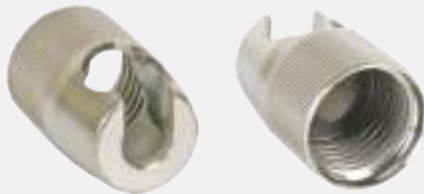

Model	Cross recessed holding cover
Art. no.	2402103

Needle scaler attachment

- ▶ For rough rust removal, weld slag removal, stone working, paint removal, plaster removal, and removal of concrete residues, ...
- ▶ Suitable for MHU, MHB PRO and MHV PRO



Model	Needle scaler attachment
Art. no.	2402600



Accessories	Shank Ø	Shaft shape	Length	Blade dimension	Art. no.
Sheet cutting chisel	10 mm	hexagonal	180 mm	20 mm	2402219
Flat chisel	10 mm	hexagonal	180 mm	20 mm	2402227
Flat chisel	10 mm	hexagonal	250 mm	30 mm	2402382
Punch chisel	10 mm	hexagonal	170 mm		2402239
Pointed chisel	10 mm	hexagonal	250 mm		2402381
Wide-flat chisel	10 mm	hexagonal	180 mm	50 mm	2402243
Wide-flat chisel	10 mm	hexagonal	250 mm	40 mm	2402383
Hollow chisel	10 mm	hexagonal	240 mm	24 mm	2402384
Clamping spring					2402101

Chisel hammer drill set MHV PRO

- ▶ Perfectly suited for building site work (brickwork, bricks, gas concrete)
- ▶ Vibration-damped and well balanced
- ▶ Kickback reduction mechanism is easy on joints
- ▶ Quick-release chuck for simple and rapid changing of the chisel
- ▶ Ergonomic, rubberised handle for excellent ease of use and safe guiding, cold-insulating and slip-proof



Model	MHV PRO	Scope of delivery:
Art. no.	2402400	
Technical specifications		
Air consumption	approx. 280 l/min	▶ Chisel hammer drills
Shank	10 mm	▶ Flat chisel
Impact rate	2 500 rpm	▶ Sheet cutting chisel, straight
Working pressure	6.3 bar	▶ Sheet cutting chisel, offset
Connection thread	1/4"	▶ Sheet cutting chisel
Weight	2.4 kg	▶ Pointed chisel
		▶ Quick clamping chuck
		▶ Plug-in nipple 1/4" OT
		▶ Clamping spring

Chisel hammer drill set MHA PRO

- ▶ Rugged professional demolition hammer drill for wall openings and renovation work
- ▶ For chisels with 12.7 mm shank



- Scope of delivery:**
- ▶ Flat chisel
 - ▶ Pointed chisel
 - ▶ Wide-flat chisel
 - ▶ Clamping spring
 - ▶ Plug-in nipple 1/4" OT

Model	MHA PRO	
Art. no.	2402500	
Technical specifications		
Air consumption	approx. 380 l/min	
Shank	12.7 mm	
Impact rate	3 600 rpm	
Working pressure	6.3 bar	
Connection thread	1/4"	
Weight	2.8 kg	

Accessories	Shaft Ø	Shaft shape	Length	Blade dimension	Art. no.
Pointed chisel	12.7 mm	hexagonal	220 mm		2402522
Flat chisel	12.7 mm	hexagonal	220 mm	16.5 mm	2402523
Wide chisel	12.7 mm	hexagonal	220 mm	50 mm	2402524
Clamping spring					2402520

Chisel hammer drill MHV PRO

- ▶ Rugged professional demolition hammer drill for wall openings and renovation work
- ▶ For chisels with 14.7 mm shank



Model	MHP PRO	
Art. no.	2402550	
Technical specifications		
Air consumption	approx. 600 l/min	
Shank	14.7 mm	
Impact rate	2 400 rpm	
Working pressure	6.3 bar	
Connection thread	3/8"	
Weight	6.9 kg	

Accessories	Shaft Ø	Shaft shape	Length	Blade dimension	Art. no.
Pointed chisel	14.7 mm	hexagonal	250 mm		2402552
Flat chisel	14.7 mm	hexagonal	250 mm	25 mm	2402553
Wide-flat chisel	14.7 mm	hexagonal	250 mm	50 mm	2402554
Pointed chisel	14.7 mm	hexagonal	400 mm		2402556
Flat chisel	14.7 mm	hexagonal	400 mm	25 mm	2402557

Special oil for compressed air tools

- ▶ For impact driving tools, sheet nibblers, grinders, drilling machines, staplers, chisels, etc.
- ▶ Protects against early wear and avoids corrosion
- ▶ Improved temperature/viscosity behaviour

Model	250 ml	1 000 ml
Art. no.	2500010	2500011
Technical specifications		
Contents	250 ml	1 000 ml



Special oil for piston compressors

- ▶ Protects against premature wear and corrosion
- ▶ Mixable with other oils of same grade
- ▶ Improved temperature/viscosity behaviour
- ▶ 20W-30 for piston-type compressors
- ▶ RSX 100 for Rotal piston-type compressors

Model	Mineral oil 20W-30 1l	Mineral oil 20W-30 5l	Special oil RSX 100 1l
Art. no.	2500012	2500015	2500017
Technical specifications			
Contents	1 000 ml	5 000 ml	1 000 ml



Staplers / Nailers

Staplers/multi-purpose tools

- ▶ Staplers for fastening leather, fabrics, wall coverings, insulation materials
- ▶ Perfect also for interior fittings, specially designed for fastening slot and key boards,

- ▶ profiles, trims, chipboard, etc.
- ▶ With rubberised handle, cold-insulating, slip-proof and low vibration

- ▶ With bottom loader magazine and contact protection
- ▶ In a handy plastic case

Stapler KG 16 PRO

- ▶ For staple sizes between 6 mm – 16 mm type 80



Model	KG 16 PRO
Art. no.	2405401

Technical specifications	
Air consumption	0.5 l/shot
Working pressure	6 bar
Matching staples	Type 80
Weight	0.9 kg

Stapler KG 32 PRO

- ▶ Professional stapler
- ▶ For staple sizes between 13 mm – 32 mm type 90
- ▶ Adjustable exhaust air outlet



Model	KG 32 PRO
Art. no.	2405301

Technical specifications	
Air consumption	0.5 l/shot
Working pressure	6 bar
Matching staples	Type 90 L, MA
Weight	1.3 kg

Nail stapler NKG 40/50 PRO

- ▶ Multi-purpose device with adjustable exhaust air outlet
- ▶ Usable staple sizes: 16 – 40 mm type 90
- ▶ Usable nail sizes: 15 – 50 mm type F



Model	NKG 40/50 PRO
Art. no.	2405501

Technical specifications	
Air consumption	0.6 l/shot
Working pressure	6 bar
Matching staples	Type 90
Matching nails	Type F
Weight	1.6 kg

Staple type 80

- ▶ Back width: 12.8 mm
- ▶ Wire thickness: 0.7 x 0.9 mm

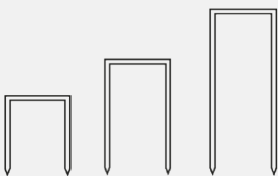

Staples	PQ	Art. no.
6 mm	5 000	2405406
10 mm	5 000	2405410
16 mm	5 000	2405416

Staple type 90

- ▶ Back width: 5.8 mm
- ▶ Wire thickness: 1.05 x 1.27 mm

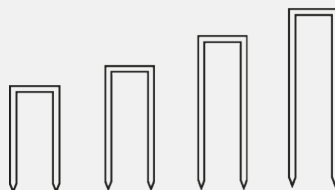

Staples	PQ	Art. no.
19 mm	5 000	2405319
25 mm	5 000	2405325
32 mm	5 000	2405332
38 mm	5 000	2405338

Staple type N

- ▶ Back width: 10.8 mm
- ▶ Wire thickness: 1.40 x 1.60 mm

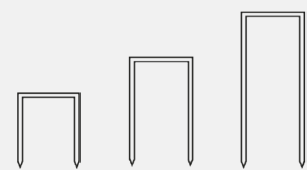

Staples	PQ	Art. no.
32 mm	10 000	2405632
38 mm	10 000	2405638
50 mm	10 000	2405650

Nail type RN

- ▶ Strip nails 34°

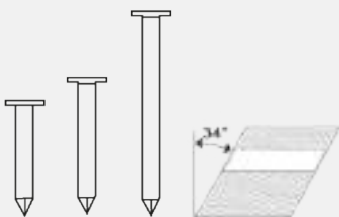

Nails	PQ	Art. no.
2.87 x 60 mm	3 000	2405960
3.10 x 70 mm	3 000	2405970
3.10 x 90 mm	3 000	2405990

Brads type F

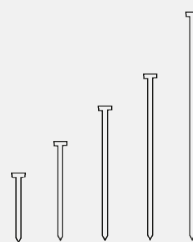

Nails	PQ	Art. no.
15 mm	5 000	2405515
25 mm	5 000	2405525
32 mm	5 000	2405532
40 mm	5 000	2405540
50 mm	5 000	2405550

Coil nails wired

- ▶ Ø 3.05 mm
- ▶ 120 pcs./coil

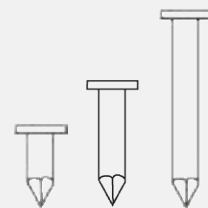

Coil nails	PQ	Art. no.
3.05 x 22 mm	7 200	2405822
3.05 x 32 mm	7 200	2405832
3.05 x 45 mm	7 200	2405845

Staplers / Nailers

- ▶ With adjustable exhaust air outlet
- ▶ For production of boxes, disposable pallets, crates, frames, dividing walls, trestles, casings, and fastening plasterboard.
- ▶ With rubberised handle, cold-insulating, slip-proof and low vibration
- ▶ With bottom loader magazine and contact protection

Stapler KG 50 PRO

- ▶ For staples 19-50 mm type N (width of back 10.8 mm)



Model	KG 50 PRO
Art. no.	2405601

Technical specifications	
Air consumption	1.8 l/shot
Working pressure	6 bar
Connection	1/4"
Weight	3.1 kg

Nailer NG 90 PRO

- ▶ For strip nails 55-90 mm with an angle of 34 degrees and diameters of 2.87 mm, 3.05 mm and 3.33 mm



Model	NG 90 PRO
Art. no.	2405905

Technical specifications	
Air consumption	4.8 l/shot
Working pressure	6 bar
Connection	1/4"
Weight	4.5 kg

Power modules - supply electricity and compressed directly to the workplace



- ▶ Water and dust protected as per IP 44 (approved for woodworking companies)
- ▶ Housing made of special plastic material equipped with handle which can also be used as tool hook
- ▶ Distribution units can be suspended at desired working height



Model	A-EA 1
Art. no.	2100001

Technical specifications	
Length of connecting hose	3 m
Compressed air hose	9 x 3 mm
Dimensions	240 x 190 x 90 mm
Weight	2 kg

Features

- ▶ 4 x safety socket with cover IP44
- ▶ 3 m power cable H07RN-F 3/5G1.5 black
- ▶ 3 m compressed air supply hose (9 x 3 mm)
- ▶ 1 x brass single-handed quick-release coupling
- ▶ 3 m galvanised steel chain



Model	A-EA 2
Art. no.	2100002

Technical specifications	
Length of connecting hose	3 m
Compressed air hose	9 x 3 mm
Dimensions	240 x 190 x 90 mm
Weight	2.4 kg

Features

- ▶ 3 x safety socket with cover IP44
- ▶ 2 x CEE sockets 400 V 16A 5p+
- ▶ 3 m power cable H07RN-F 3/5G1.5 black
- ▶ 3 m compressed air supply hose (9 x 3 mm)
- ▶ 1 x brass single-handed quick-release coupling
- ▶ 3 m galvanised steel chain

Hoses/Spiral hoses

FLEXAIR hose

- ▶ Extremely flexible compressed air hose also for low temperatures
- ▶ Especially resistant against oil-contaminated compressed air
- ▶ Operating pressure max: 15 bar
- ▶ With coupling and barb



Extremely flexible woven fabric compressed air hose even at low temperatures

Hose length	ID	OD	Art. no.
10 m	6 mm	10.7 mm	2105410
20 m	6 mm	10.7 mm	2105420
10 m	9 mm	14.5 mm	2105510
20 m	9 mm	14.5 mm	2105520

FLEXAIR hose

- ▶ Extremely flexible compressed air hose also for low temperatures
- ▶ Especially resistant against oil-contaminated compressed air
- ▶ Operating pressure max: 15 bar



Extremely flexible woven fabric compressed air hose even at low temperatures

Hose length	ID	OD	Art. no.
50 m	6 mm	11 mm	2105450
10 m	9 mm	14 mm	2105511
50 m	9 mm	14 mm	2105550
50 m	13 mm	19 mm	2105750

Quality compressed air hose PRO

- ▶ Highly flexible and abrasion-proof
- ▶ Temperature range from -40° to +75°
- ▶ Max. working pressure: 15 bar
- ▶ Made of polyurethane
- ▶ With fabric insert - fabric reinforced
- ▶ For professional use



PU hose 10 m
With coupling and barb

PU hose 50 m

Hose length	ID	OD	Art. no.
10 m*	8 mm	12 mm	2106910
50 m**	8 mm	12 mm	2106950
50 m**	10 mm	15 mm	2106960
50 m**	13 mm	19 mm	2106970

*With coupling and barb **On reel

Standard spiral hose

- ▶ With quick-release coupling and barb
- ▶ Entry level

Spiral hose

- ▶ Made of polyurethane
- ▶ with standard quick-release coupling and barb



With standard quick-release coupling and barb

Hose length	Max. operating pressure:	ID	OD	Art. no.
5 m	8 bar	6 mm	10 mm	2115605
7.5 m	8 bar	6 mm	10 mm	2115608
10 m	8 bar	8 mm	12 mm	2115610

Quality spiral hoses

- ▶ With quick-release coupling and barb
- ▶ Professional design

Quality spiral hose PRO

- ▶ Made of polyurethane
- ▶ Highly flexible and abrasion-proof
- ▶ Connecting thread 1/4"
- ▶ Avoids permanent reduction of cross-section after kinking
- ▶ Small winding diameter
- ▶ Large temperature range
- ▶ The straight ends allow for convenient plugging and unplugging, and torsion-free work
- ▶ No hose torsion thanks to swivel joint
- ▶ With kink protection

With swivel joint - 360° rotatable



Highly flexible with swivel joint and kink protection including quality coupling and barb



Quality spiral hose PRO 6 m, 5/8 mm ID/OD with particularly narrow winding



Quality spiral hose 6m PRO 8/12 mm

Hose length	Max. operating pressure:	ID	OD	Art. no.
6 m	8 bar	5 mm	8 mm	2105850
6 m	8 bar	6.5 mm	10 mm	2105852
6 m	8 bar	8 mm	12 mm	2105854
10 m	8 bar	8 mm	12 mm	2105856

Antistatic compressed air hose

- ▶ Guarantees electrostatic contact (106Ωm) when attaching the hose to couplings



Antistatic



Model	10 m with coupling and barb	50 m reel
Art. no.	2100110	2100101
Technical specifications		
Length	10 m	10 m
Hose Ø	9 x 16 mm	9 x 16 mm
Working pressure at 20 °C	16 bar	16 bar
Burst pressure at 20 °C	60 bar	60 bar

Balancers FZ

- ▶ Essential tool for repetitive work on assembly lines, mass production packaging work
- ▶ Extremely resilient spring cable pull
- ▶ Made of high-quality die-cast aluminium
- ▶ Load setting and cable length selectable
- ▶ Three-point hitch



The following are recommend for connection to the compressed air network:

- 1x quick coupling 6 mm
- With hose barb (2200021),
- Plug-in barb 6 mm (2200031)
- and 2x ear clamps (2105008)

Model	FZ 0.4 - 1.0 kg	FZ 1.0 - 2.0 kg	FZ 2.0 - 3.0 kg
Art. no.	2106001	2106002	2106003
Technical specifications			
Load bearing range	0.4 – 1 kg	1 – 2 kg	2 – 3 kg
Cable length	1.6 m	1.6 m	1.6 m
Dimensions in mm	113 x 113 x 60	113 x 113 x 60	113 x 113 x 60
Weight	0.63 kg	0.63 kg	0.63 kg

Ear clamps PRO



For hose	Range	PQ	Art. no.
12.3 mm	9.8 - 12.3 mm	4	2105006SB
12.3 mm	9.8 - 12.3 mm	100	2105006
13.3 mm	10.8 - 13.3 mm	4	2105008SB
13.3 mm	10.8 - 13.3 mm	100	2105008
15.7 mm	13.2 - 15.7 mm	4	2105009SB
15.7 mm	13.2 - 15.7 mm	100	2105009
17.8 mm	15.6 - 17.8 mm	100	2105011
19.8 mm	16.6 - 19.8 mm	100	2105012

Hose connection studs



Accessories	Art. no.
8 mm hose connection ports, Y-shaped	22536613

Spiral hose for balancers

- ▶ High-quality PA12 spiral hose for attachment to balancers FZ
- ▶ Keeps things tidy in the assembly line work area
- ▶ 1 m connecting hose for connecting to the compressed air network and tool
- ▶ Incl. all required parts for mounting on the balancer
- ▶ PA12 Spiral hose



The following are recommend for connection to the compressed air network:

- 1x quick coupling 6 mm
- With hose barb (2200021),
- Plug-in barb 6 mm (2200031)
- and 2x ear clamps (2105008)

Model	Spiral hose for balancers
Art. no.	2106050
Technical specifications	
Useful length with spring balancer	1.6 m
ID	8 mm
OD	10 mm



Fig. shows the use of the spiral hose. **Spring balancer not included in scope of delivery**

Hose rewinders/Hose reels

Hose rewriter

Hose rewriter SAR E

- ▶ Including swivelling bracket for wall or ceiling mounting
- ▶ Compressed air hose made of polyurethane with woven fabric insert
- ▶ The hose can be easily arrested or automatically rolled up, simply by pulling
- ▶ With coupling and barb



with standard quick-release coupling and barb

Model	SAR 8/10 E	SAR 8/15 E
Art. no.	2105804	2105806

Technical specifications

Hose internal diameter	8 mm	8 mm
Hose external diameter	12 mm	12 mm
Hose length	10 m	15 m
Max. operating pressure:	15 bar	15 bar
Connection	1/4" OT	1/4" OT
Weight	3.6 kg	7.0 kg

Hose rewriter SAR PRO

- ▶ Premium compressed air hose made of polyurethane with woven fabric support
- ▶ For professional use in workshops, garages etc.
- ▶ Rugged, powder-coated sheet steel housing with bracket for wall and ceiling mounting
- ▶ The hose can be arrested at any point by simply pulling, or rewound as desired
- ▶ Length of connecting hose: 2 m



Highly flexible with kink protection, including quality coupling and barb

Model	SAR 8/15 PRO	SAR 10/15 PRO	SAR 13/12 PRO
Art. no.	2105813	2105814	2105817

Technical specifications

Hose internal diameter	8 mm	10 mm	13 mm
Hose external diameter	12 mm	15.5 mm	18 mm
Hose length	15 m	15 m	12 m
Max. operating pressure:	15 bar	15 bar	15 bar
Connection	1/4"	3/8"	3/8"
Weight	6.0 kg	7.0 kg	7.5 kg

Hose rewriter SAR TOP

- ▶ Housing made of impact-resistant plastic · With kink protection
- ▶ Including swivelling bracket for wall or ceiling mounting
- ▶ Woven-fabric armoured, oil-resistant polyurethane (PU) hose
- ▶ With premium quick-action coupling and barb
- ▶ Operating temperature: from -5 °C to +40 °C
- ▶ Length of connecting hose: 1 m



woven fabric armoured, oil-resistant, with kink protection, including quality coupling and barb

Model	SAR 8/15 TOP	SAR 10/15 TOP
Art. no.	2105815	2105818

Technical specifications

Hose internal diameter	8 mm	10 mm
Hose external diameter	12 mm	14 mm
Hose length	15 m	15 m
Max. operating pressure:	15 bar	15 bar
Connection	1/4"	3/8"
Weight	6.0 kg	6.5 kg

Wall-mounted hose rewriter SAR 10/15 M

- ▶ Compressed air hose made of polyurethane with woven fabric insert
- ▶ With premium quick-action coupling and barb
- ▶ Rugged metal housing
- ▶ For ceiling and floor mounting
- ▶ The hose can be easily arrested or automatically rolled up, simply by pulling



Highly flexible with kink protection, including quick coupling and barb

Model	SAR 10/15 M
Art. no.	2105816

Technical specifications

Hose internal diameter	9.5 mm
Hose external diameter	14 mm
Hose length	15 m
Max. operating pressure:	15 bar
Weight	12.25 kg

Hose reels

New

Compressed air hose drum DST 8/31



Highly flexible with kink protection, including quality coupling and barb

- ▶ Polyurethane hose with woven fabric support
- ▶ With kink protection
- ▶ On stand, swivels through 360°
- ▶ Highly flexible and abrasion-proof
- ▶ With premium quick-action coupling and barb

Model	DST 8/31
Art. no.	2105831

Technical specifications	
Hose on reel ID	8 mm
Hose on reel OD	12 mm
Connecting hose ID	6.5 mm
Connecting hose OD	10 mm
Hose length	30 m
Operating pressure	8 bar
Connection	1/4"
Weight	10 kg



360° rotating



Cable reel

- ▶ Automatic cable rewinders for hobby, agriculture, trade and industry
- ▶ Keeps any workshop tidy
- ▶ Swivelling thanks to stable wall or ceiling mount

- ▶ The cable can be easily arrested or automatically rolled up, simply by pulling
- ▶ With thermal overload protection as standard
- ▶ Cable quality H05VV-F

KAR PRO Series special features

- ▶ Housing made of impact-proof plastic material
- ▶ Locking mechanism can be switched off
- ▶ With strong return spring made of special steel
- ▶ Very uniform and complete return of the electrical cable

Cable reel KAR

- ▶ 230 volt model with safety plug and socket
- ▶ All suspension devices are included in the delivery volume



Model	KAR 3 x 1.5 10 metres	KAR 3 x 1.5 15 metres
Art. no.	2161211	2161213

Technical specifications

Cable dimensions	3 x 1.5 mm ²	3 x 1.5 mm ²
Cable length	10 m	15 m
Weight	3.6 kg	7.0 kg

Performance

Cable rolled	1 100 W	1 100 W
Cable unrolled	3 200 W	3 200 W

Cable reel KAR PRO

- ▶ 230 volt model with safety plug and socket
- ▶ Rated load cable rolled: 800 W
- ▶ Rated load cable unrolled: 2000 W



Model	KAR PRO 3 x 1.5 18 metres	KAR PRO 3 x 1.5 25 metres
Art. no.	2162318	2162325

Technical specifications

Cable dimensions	3 x 1.5 mm ²	3 x 1.5 mm ²
Cable length	18 m	25 m
Length	360 mm	420 mm
Width	200 mm	200 mm
height	330 mm	390 mm
Weight	4.8 kg	8.3 kg

Cable reel KAR PRO

- ▶ 400 volt model with 5 x 16 A Euronorm plug and socket
- ▶ Rated load cable rolled: 1 000 W
- ▶ Rated load cable unrolled: 3 000 W



Model	KAR PRO 5 x 1.5 10 metres	KAR PRO 5 x 1.5 20 metres
Art. no.	2164010	2164020

Technical specifications

Cable dimensions	5 x 1.5 mm ²	5 x 1.5 mm ²
Cable length	10 m	20 m
Length	360 mm	420 mm
Width	260 mm	260 mm
height	330 mm	390 mm
Weight	5.3 kg	9.8 kg

Sandblasting cabinets

SSK Series - Sandblasting cabins for clean blasting work without soiling the work environment

- ▶ Suitable for a variety of blasting agents, e.g. quartz, glass peen shot, plastic peen shot, and more
- ▶ Ideal for paint removal or for cleaning and rust removal on metal parts of any type
- ▶ Premium latex work gloves fastened on housing
- ▶ View window and adhesion-bonded protective film, for the best possible view and

- occupational protection while processing the workpiece
- ▶ Cover and door frame featuring all-around seals for dust-free work
- ▶ With stable grid shelf for depositing workpieces on the inside of the cabinet
- ▶ With drain opening for changing the blasting agent

- ▶ Extraction hose for blasting agent fastened on bottom of catchment container
- ▶ With external compressed air coupling
- ▶ Glass bead blasting agent, corundum blasting agent, silicon carbide, plastic blasting agent and many others usable



SSK 1

- ▶ 12-volt neon tube with 230-volt power supply and external switch



SSK 1.5

- ▶ Maximum working pressure controllable via pressure controller with pressure gauge
- ▶ Air flow controlled via foot pedal
- ▶ 12-volt neon tube with 230-volt power supply and external switch
- ▶ Integrated extraction unit with replaceable air filter



SSK 2

- ▶ One large door on the side for loading and unloading
- ▶ Two exhaust air openings (1 exhaust air connection \varnothing 92 mm and 1 exhaust air duct \varnothing 64 mm) for connecting to an extraction unit
- ▶ 12-volt neon tube with 230-volt power supply and external switch



SSK 2.5

- ▶ Two large doors for loading and unloading at both sides, also for longer workpieces
- ▶ Integrated extraction unit with replaceable air filter
- ▶ Air flow controlled via foot pedal
- ▶ Two blasting guns: one fixed and one freely-movable blasting gun
- ▶ Three separate switches for on/off, extraction and cell lighting
- ▶ Two neon tubes (230-volt), in separate housing with protective pane and replaceable protective film, including 5 replacement films
- ▶ Maximum working pressure controllable via pressure controller with pressure gauge

Scope of delivery SSK 1/2/2.5/3.1/4:

- ▶ Premium blasting gun with ceramic nozzle
- ▶ 5 replacement films for view window
- ▶ **SSK 1/2/3.1/4:** 4 ceramic nozzles (4 / 5 / 6 / 7 mm)
- ▶ **SSK 2.5:** 4 ceramic nozzles (2 x 6 mm/ 2 x 7 mm)

Scope of delivery SSK 1.5:

- ▶ 3 ceramic nozzles (3.5 mm)
- ▶ 3 replacement films for view window

Model	SSK 1	SSK 1.5	SSK 2	SSK 2.5
Art. no.	6204000	6204010	6204001	6204003
Cabin volume	90 l	25.4 l	220 l	310 l
Air consumption approx.	200 – 350 l/min	196 l/min	200 – 350 l/min	200 – 350 l/min
Working pressure	2.8 – 8.0 bar	5.5 – 7.9 bar	2.8 – 8.0 bar	4.1 – 8.0 bar
Max. inlet pressure	8.6 bar	8.5 bar	8.6 bar	8.3 bar
Compressed air connection	3/8"	1/4"	3/8"	3/8"
Abrasive grain size	0.12 – 0.18 mm	0.12 – 0.25 mm	0.12 – 0.25 mm	0.125 – 0.42 mm
Cabin interior dimensions (L x W x H)	580 x 480 x 300 mm	410 x 310 x 200	840 x 550 x 360 mm	945 x 605 x 605 mm
Exterior dimensions (L x W x H)	590 x 485 x 490 mm	475 x 370 x 370	950 x 660 x 1 380 mm	960 x 900 x 1 640 mm
Weight	17.25 kg	12.5 kg	48 kg	90 kg
Max. weight on support grille	10 kg	10 kg	80 kg	120 kg
max. weight of blasting agent	12 kg	5.45 kg	50 kg	50 kg
Extraction performance	–	–	–	7.9 m ³ /h
Extraction unit current draw	–	–	–	1200 W
Extraction unit negative pressure	–	–	–	8.5 kPa
Extraction unit volume flow	–	–	–	156 m ³ /h

Accessories for SSK 1	PQ	Art. no.	Accessories for SSK 1.5	PQ	Art. no.	Accessories for SSK 2	PQ	Art. no.	Accessories for SSK 2.5	PQ	Art. no.
Gloves		6204100	Gloves		6204160	Sand blasting gun		6204101	Sand blasting gun		6204101
Sand blasting gun		6204101	Filter		6204162	Gloves		6204110	Sand blasting gun fixed		6204105
Filter		6204102	Ceramic nozzle 3.5 mm		6204163	Protective film	5	6204111	Gloves		6204120
Protective film	5	6204103	Protective film	5	6204164	View window		6204112	Filter		6204123
View window		6204104	View window		6204165	Fluorescent tube		6204113	Protective film	5	6204111
Ceramic nozzle set 4/5/6/7 mm		6204130	Fluorescent tube		6204166	Ceramic nozzle set 4/5/6/7 mm		6204130	View window		6204122
Composite nozzle 6 mm		6204132				Composite nozzle 6 mm		6204132	Fluorescent tube		6204127
Fluorescent tube		6204113							Protective pane for lighting		6204125
									Protective film for lighting	5	6204126
									Ceramic nozzle set 4/5/6/7 mm		6204130
									Composite nozzle 6 mm		6204132



Sand blasting gun fixed (Art. no.: 6204105)



Composite nozzle 6 mm (Art. no.: 6204132)



Boron carbide nozzle 6 mm (Art. no.: 6204133)



Fig. shows SSK 3.1 featuring a very large front flap which opens upward



SSK 3.1/SK 4:
Integrated extraction unit with replaceable air filter



SSK 3.1

- ▶ Very large front hood opens upward for fast and easy loading and unloading
- ▶ Integrated extraction unit with replaceable air filter
- ▶ Blasting gun without trigger - air flow controlled via foot pedal
- ▶ Two neon tubes (230-volt), in separate housing with protective pane and replaceable protective film, including 5 replacement films
- ▶ Light switch with dual function: extraction and cabin lighting are switched on and off at the same time
- ▶ Maximum working pressure controllable via pressure controller with pressure gauge

SSK 4

- ▶ Very large front hood opens upward for fast and easy loading and unloading
- ▶ Integrated extraction unit with replaceable air filter
- ▶ Blasting gun without trigger - air flow controlled via foot pedal
- ▶ Four neon tubes (230-volt), in separate housing with protective pane and replaceable protective film, including 5 replacement films
- ▶ Two separate switches for on/off, extraction and cell lighting
- ▶ Maximum working pressure controllable via pressure controller with pressure gauge
- ▶ Cross-beams on base allow for easy transport with a pallet truck



Fig. shows SSK 4 application

Model	SSK 3.1	SSK 4
Art. no.	6204005	6204004
Cabin volume	360 l	825 l
Air consumption approx.	400 – 800 l/min	400 – 800 l/min
Working pressure	3.4 – 8.0 bar	3.4 – 8.0 bar
Max. inlet pressure	8.6 bar	8.6 bar
Compressed air connection	3/8"	3/8"
Abrasive grain size	0.125 – 0.42 mm	0.125 – 0.42 mm
Cabin interior dimensions (L x W x H)	1 160 x 580 x 580 mm	1 160 x 870 x 850 mm
Exterior dimensions (L x W x H)	1 225 x 935 x 1 640 mm	1 320 x 1 200 x 1 760 mm
Weight	115 kg	160 kg
Max. weight on support grille	120 kg	150 kg
max. weight of blasting agent	75 kg	75 kg
Extraction performance	17.4 m³/h	17.4 m³/h
Extraction unit current draw	1 200 W	1 200 W
Extraction unit negative pressure	8.5 kPa	8.5 kPa
Extraction unit volume flow	156 m³/h	156 m³/h

Grain sizes usable

U.S.mesh	Zoll	mm	µm
60	0.0098	0.250	250
70	0.0083	0.210	210
80	0.0070	0.177	177
100	0.0059	0.149	149
120	0.0049	0.125	125

Accessories for SSK 3.1	PQ	Art. no.	Accessories for SSK 4	PQ	Art. no.
Gloves		6204120	Sand blasting gun		6204124
Protective film	5	6204111	Gloves		6204120
View window		6204122	Filter		6204123
Filter		6204123	Protective film	5	6204151
Sand blasting gun		6204124	View window		6204150
Protective pane for lighting		6204125	Fluorescent tube		6204152
Protective film for lighting	5	6204126	Protective pane for lighting		6204154
Fluorescent tube		6204127	Protective film for lighting	5	6204153
Boron carbide nozzle 6 mm		6204133	Boron carbide nozzle 6 mm		6204133
Boron carbide nozzle 7 mm		6204134	Boron carbide nozzle 7 mm		6204134
Ceramic nozzle set		6204131	Ceramic nozzle set		6204131
2 x 6 mm / 2 x 7 mm			2 x 6 mm / 2 x 7 mm		

dryCAT series – M and H class dry vacuum cleaners for toxic and hazardous substances

- ▶ Dry vacuum cleaner models for dust and other solid particulate matter
- ▶ Motors equipped with copper windings and motor circuit breaker for a long service life
- ▶ Cartridge filter with an extremely large filter surface ensures constant vacuuming performance
- ▶ Antistatic components included in scope of delivery
- ▶ Elastic and flexible suction hose resilient to heavy loads and any kind of twisting
- ▶ Hose connection on container with locking mechanism prevents the hose coming loose during cleaning
- ▶ Ergonomic head design with cable hooks
- ▶ 2-motor models with separate on/off switches. The operator can choose how many motors to work with. This allows for substantial energy savings
- ▶ Suction motors with noise damping to ensure quiet operation



DUST CLASS M
Suitable for separating dust with an occupational exposure threshold of more than 0.1 mg/m³, such as wood dusts, paints, ceramics.

Vacuuming toxic and hazardous materials calls for a vacuum cleaner which filters particles that legacy models simply emit into the ambient air, and which would thus pose a health hazard.



dryCAT 137 RSCM



dryCAT 133 IRSCM

M CLASS VACUUM CLEANERS



M CLASS VACUUM CLEANERS



Info & video



Model	dryCAT 137 RSCM	dryCAT 133 IRSCM
Art. no.	7002150	7002145
Vacuum cleaner type	dry	
Rating	1 kW	
Volume of air	3 333 l/min	
Tank volume	37 l	33 l
Hose diameter/length	38 mm/4 m	
Number of motors	1	
Motor cooling	Bypass	
Sound pressure level	72 dB(A)	
Electrical connection	230 V ~50 Hz	
Cable length	8.5 m	
Max. rating device socket outlet	2.6 kW	
Negative pressure	223 mbar	
Tank material	Plastic	stainless steel
Dimensions (L x W x H)	390 x 390 x 900 mm	430 x 430 x 830 mm
Weight	15 kg	

Antistatic



Scope of delivery:

- ▶ Suction hose 4 m, handle with loss-air control, pluggable suction tube, dry floor attachment, round attachment with brush, flat nozzle, reduction piece, cartridge filter



DUST CLASS H

Suitable for separating dusts with all occupational exposure threshold limits, including cancerogenic and pathogenic dusts, e.g., mould, lead or arsenic.

New

With practical vacuum tube holder on the chassis

Plastic chassis and holders for attachments and suction tube

With appliance socket and automatic start-up



dryCAT 133 ISC-HC



dryCAT 262 ISCT-HC



Model	dryCAT 133 IC-HC	dryCAT 262 ICT-HC
Art. no.	7002155	7002255
Vacuum cleaner type	dry	
Rating	1 kW	2 kW
Volume of air	3 583 l/min	7 166 l/min
Tank volume	33 l	62 l
Hose diameter/length	38 mm/4 m	
Number of motors	1	2
Motor cooling	Bypass	
Sound pressure level	74 dB(A)	80 dB(A)
Electrical connection	230 V ~50 Hz	230 V ~50 Hz
Cable length	8.5 m	
Max. rating device socket outlet	-	
Negative pressure	245 mbar	
Tank material	stainless steel	
Dimensions (L x W x H)	430 x 430 x 830 mm	520 x 520 x 960 mm
Weight	16 kg	23 kg



Scope of delivery:
 > Suction hose 4 m, handle with loss-air control, pluggable suction tube, dry floor attachment, round attachment with brush, flat nozzle, reduction piece, cartridge filter

YOU WILL FIND MORE PRODUCTS IN OUR MAIN CATALOGUES



optimum-maschinen.com



optimum-maschinen.com



metallkraft-machines.com



holzkraft-machines.com
holzstar.com



schweisskraft.com



en.unicraft.de



cleancraft.eu

DISCOVER OUR PRODUCT VIDEOS NOW!



Stürmer Maschinen GmbH (English channel)



Are you familiar with our YouTube channel, **Stürmer Maschinen GmbH**?

You can view all of our product videos here, sorted by brand. We always seek to offer you a **wide range** and **high quality selection** of videos.

Subscribe to our YouTube channel, to avoid missing any of the new videos:
www.stma.de/youtube-en

Your specialist retailer:



Sales Germany:

AIRCRAFT - Stürmer Maschinen GmbH

Dr.-Robert-Pfleger-Str. 26
96103 Hallstadt/Germany

Phone: +49 (0) 9 51 - 96 555 - 0

Fax: +49 (0) 9 51 - 96 555 - 55

Email: info@aircraft-kompressoren.de



www.aircraft-kompressoren.com

Manufacturing and distribution in Austria:

Aircraft Kompressorenbau GmbH

Gewerbestraße Ost 6
4921 Hohenzell / Austria

Phone: +43 (0) 77 52 - 70 929 - 0

Fax: +43 (0) 77 52 - 70 929 - 99

email: info@aircraft.at

Web: www.aircraft.at

- These offers are intended exclusively for business owners, retailers and tradespersons who are making a purchase in pursuit of their profession or self-employment. This is an explicit CONDITION FOR THE CONCLUSION OF A CONTRACT. Consumers are not eligible to purchase as per Section 13 BGB (German Civil Code).
- The publication of this catalogue renders all previous price lists invalid.
- Prices are recommended retail prices, subject to change, in €, plus statutory VAT, plus packaging, shipping, transportation, unloading, installation and training costs as applicable.
- We accept no liability for printing errors, mistakes or incorrect representation.
- Technical and visual changes reserved.
- Some illustrations show optional accessories.
- Delivery is effected solely on the basis of our terms of delivery and payment.
- All items are sold through specialist retailers.
- The goods shall remain our property until payment has been received in full.
- Our retention of title shall remain valid in case of sale to a third-party.
- Legal warranty conditions apply for businesses.
- Copying and reproduction in full or in part is subject to written approval by us.
- Please note that transport packaging surcharges apply for some machines in this catalogue to cover transport units, packaging and packaging overheads. These machines are appropriately marked in the catalogue.